

Project name: Service

Manual for Engine

LXFD0901-054



Loncin Engine co. ltd. March 2023

## Foreword

There are more and more motorcycles getting onto market with each passing day, and new structure and technologies are also adopted. For all the Loncin users and service workers know well about the maintenance, adjustment and repair for engine KEL900, we made this service manual and hope which bring you more convenience when you need them.

All the data in this book including diagrams, performance and other data are all the latest until it printed. The Loncinmotor.co.ltd. reserves the right for further revision without any notice in advance. Any part in this book belongs to Loncin copyright, any person or company is unable to re-print unless got Loncin writing authorization in advance.

## Content list

Rules for maintenance.....	5
Specification.....	6
Torque.....	10
Position for lubrication and sealing.....	13
2. Maintenance.....	14
Maintenance information.....	14
Breathing tube of crankcase.....	15
Spark plug.....	16
Valve clearance.....	16
Oil in engine.....	20
Secondary oil filter.....	22
Engine idling.....	23
Clutch.....	23
3. Cooling system.....	25
Cooling system specification.....	25
Troubleshooting.....	26
System procedure mode.....	27
Cooling system test.....	28
Coolant replacement.....	29
Thermostat.....	31
Heat radiator/Cooling fan.....	34
Water pump.....	36
4. Lubrication system.....	39
Maintenance information.....	39
Inspection for oil pressure.....	43
Oil pump.....	44
Pressure relief valve.....	47
Primary oil filter.....	48
Specification for cylinder head/Valves.....	52
Cylinder compression test.....	54
Cylinder head cover.....	55
Camshaft.....	56
Swinging arm.....	63

Cylinder head.....	64
Tensioner and its covering plate.....	71
.....	72
Timing chain/Sprocket.....	72
Specification for clutch and gearshift device.....	75
Right crankcase cover.....	76
Clutch.....	78
Gearshift device.....	83
Specification for magneto and starting clutch.....	86
Left crankcase cover.....	86
Stator of magneto and crankshaft.....	88
position sensor.....	88
Stator of magneto.....	89
Starting clutch.....	92
Maintenance information.....	95
Specification for crankcase body and transmission system.....	96
Crankcase body.....	97
Transmission.....	102
Crankshaft.....	106
Shaft pad of journal for main shaft.....	109
Shaft pad for crankshaft.....	112
Piston/Cylinder body.....	116
Oil nozzle for piston.....	119
Rear balancing shaft.....	119

# 1. Summary

## Rules for maintenance

1. Please adopt the Loncin motor co.ltd. produced or suggested spare parts, lubricant or other auxiliary materials when maintenance is necessary. In case materials were adopted fail to meet Loncin standard, it may damage your motorcycle.
2. When maintenance is necessary, please adopt the tools, bolt, nut and screw in metric standard, the ones out of metric standard such as imperial standard are not allowed, because they are not interchangeable to metric ones.
3. When parts were replaced or re-assembled, please also replace their washer, o-ring, split pin and locking piece.
4. Please fasten the bolt or nut with bigger diameter or inside first, then fasten the rest in alternative angle sequence, unless there is another specially stipulated sequence.
5. Wash up the removed parts by cleanser. Coat the moving surface with lubricant before re-assembling.
6. When re-assembled, please check and confirm the correct re-assembly and proper operation, turn, move and operate them for checking.
7. Dispose the used oil, lubricant, pollutants and abandoned parts by strictly following laws and other state regulations.

# Specification

## General specification

	Item	Data
Engine	Type Displacement Cylinder arrangement and angle Bore×Stroke Combustion chamber capacity Compression ratio Max. power and its rotation Max. torque and its rotation Air valve device Lubrication system Cooling system Engine net weight	LX286MX 895ml Left: 1, Right: 2; 15° 86×77mm 26.1 ml 13.1: 1 72Kw/8500rpm 91N·m/7000rpm DOHC Forced pressure + Splashing lubrication Water cooling 65kg
Transmission system	Clutch Gear box Primary transmission ratio End transmission ratio Gear transmission ratio Gearshift method	Multiple wet layers International 6 gears 1.821 2.588 1 <sup>st</sup> : 2.8332 <sup>nd</sup> : 2.067 3 <sup>rd</sup> : 1.600 4 <sup>th</sup> : 1.308 5 <sup>th</sup> : 1.1036 <sup>th</sup> : 0.968 1-N-2-3-4-5-6
Electrical system	Ignition system Starting system Lighting system Spark plug specification Spark plug clearance Rectifier regulator	FGM-FI 1-2 Complete electric starting Battery LMAR9J-9E (NGK) 0.8-0.9mm 3 phases complete wave regulator

## Cooling system specification

Items		Specification
Coolant capacity	Heat radiator and engine	1.5 L
	Sub tank	0.38 L
Relief pressure for heat radiator cover		120-150kPa
Thermostat	Initial temperature	83-87°C
	Complete temperature	95°C
	Valve rise	7mm
Coolant we suggested		GLYSANTIN G48-24
Standard thickness of coolant		Mixture with distilled water by 1:1

## Lubrication system specification Unit: mm

Items		Standard	Maintenance limit
Oil capacity	When oil replaced	2.7 L	—
	When oil filter replaced	3.0 L	—
	When engine broke up	3.2 L	—
Oil we suggest		The engine oil we suggest: 5W-40 API quality grade: SL or higher (Please don't adopt energy saving oil which marked up on API service label) JASO T903 Standard: MA2 Viscosity: SAE 5W-40	—
Oil pump rotor	Clearance between impeller tips	0.15	0.20
	Middle clearance	0.15-0.21	0.35
	Clearance between sides	0.02-0.09	0.12

## Specification for cylinder head/Valves Unit: mm

Items		Standard	Maintenance limit
Pressure in cylinder of electrical starting		450-600kPa	—
Valve clearance	Air inlet	0.11-0.20	—
	Air exhaust	0.26-0.35	—
Swinging arm and its shaft	Inner diameter of arm	In/Exhaust	8.013-8.028
	Outer diameter of shaft	In/Exhaust	7.986-7.995
	Clearance between arm and shaft	In/Exhaust	0.018-0.042
Camshaft	Height of protrusion	Air inlet	36.226-36.288
		Air exhaust	36.050-36.112

	Clearance between journal and hole		0.020-0.056	0.07
	Runout		—	0.01
Valve and its guiding tube	Rod diameter of valve	Air inlet	4.966-4.980	4.956
		Air exhaust	4.956-4.970	4.946
	Inner diameter of valve guiding tube	In/Exhaust	5.000-5.012	5.04
	Clearance between valve rod and its guiding tube	Air inlet	0.02-0.046	0.07
		Air exhaust	0.03-0.056	0.08
	Height of guiding tube	In/Exhaust	12.60-13.20	—
Width of gate line for base ring	Air inlet	1.00-1.10	1.5	
	Air exhaust	1.10-1.20	1.6	
Free length of valve spring			46.30	45.1
Flatness of cylinder head			0.05	0.10

Specification for clutch operation system Unit: mm

Items	Standard	Maintenance limit
Free travel for clutch lever	10-20	—

Specification for magneto and starting clutch Unit: mm

Items	Standard	Maintenance limit
Outer diameter for shaft jacket of starting plate shaped gear	51.705-51.718	51.685
Outer diameter for outer case of starting clutch	68.364-68.390	68.400

Specification for case body and transmission system Unit: mm

Items		Standard	Maintenance limit	
Transmission mechanism	Diameter of inner hole on gear	Main shaft 6 and 5	30.000-30.013	30.03
		Countershaft 1, 2, 3 and 4	34.000-34.016	34.03
	Width for needle bearing	Main shaft 6 and 5	12.45-12.80	12.4
		Countershaft 1, 2, 3 and 4	12.45-12.80	12.4
	Shaft diameter for main shaft	Match up with needle bearing of main shaft 6 and 5	25.982-25.993	25.97
		Match up with needle bearing of countershaft 1, 2,	29.980-27.993	29.96

		3, and 4		
Gearshift fork and its shaft	Shaft diameter of gearshift shaft		11.967-11.994	11.96
	Inner diameter of gearshift turning fork		12.016-12.043	12.06
	Thickness for fork tip		4.85-4.95	4.8
	Opening diameter of turning fork	Left and right fork	46.55-46.85	46.9
Middle fork		34.05-34.35	34.4	
Opening on gear	Width of opening	Main shaft 3-4	5.05-5.13	5.2
		Counter shaft 5 and 6	5.05-5.13	5.2
	Diameter	Main shaft 3-4	33.85-33.95	33.7
	Diameter	Counter shaft 5 and 6	45.85-45.95	45.7

### Specification for crankshaft, piston, cylinder hole and balancing shaft

Unit: mm

Items		Standard	Maintenance limit	
Crankshaft	Clearance at bigger end of connecting rod	0.10-0.25	0.27	
	Clearance between shaft pad on bigger end of connective rod and the shaft	0.034-0.059	0.065	
	Clearance between journal of crankshaft and shaft pad	0.030-0.058	0.065	
	Runout	—	0.035	
Cylinder	Cylinder bore	85.994-86.006	86.05	
	Roundness loss	—	0.10	
	Taper	—	0.10	
	Cylindricity	—	0.10	
Piston, piston pin and piston rings	Diameter of basic circle for piston		85.956-85.974	85.90
	Diameter for pin's hole		19.008-19.013	19.02
	Diameter of piston pin		18.992-19.000	18.98
	Clearance between piston and its pin		0.008-0.021	0.04
	Closing clearance of piston ring	1 <sup>st</sup> ring	0.15-0.30	0.4
		2 <sup>nd</sup> ring	0.20-0.40	0.5
		Oil ring	0.20-0.70	1.0
	Clearance between piston ring and its groove	Clearance between 1 <sup>st</sup> ring and its groove	0.030-0.070	0.10
Clearance between 2 <sup>nd</sup> ring and its groove		0.020-0.060	0.08	
Clearance for cylinder matching		0.020-0.050	0.10	
Smaller end of connecting rod and its inner diameter		19.017-19.027	19.035	
Matching clearance between connecting rod and its pin		0.017-0.035	0.05	

# Torque

## Standard torque

Fastening piece type	Torque N.m
Bolt 5mm	6
Bolt 6mm	10
Bolt 7mm	20
Bolt 8mm	25
Bolt 10mm	35
Bolt 12mm	70

## Engine torque

Items	Qty.	Thread diameter mm	Torque N.m	Note
Installation screw for air filter	4	5	1.1	
Screw for air filter element	4	5	1.5	
Spark plug	2	10	12	
Screw plug for swinging arm shaft	2	10	15	Replace washer for a new one
View hole cap	1	24	10	Coat seal ring with grease of MP3
Oil drainage screw plug on oil bottom case	1	16	25	Replace washer for a new one
Oil drainage screw plug for oil tray	1	10	10	Replace washer for a new one
Secondary oil filter	1	18	11	
Tube joint of secondary oil filter	1	20	35	

## Cooling system

Items	Qty.	Thread diameter mm	Torque N.m	Note
Bolt on cover of fan's motor	4	6	8.5	
Screw of fan's motor	3	4	2.8	
Nut of fan	1	3	1.1	Coat thread with sealant

Installation bolt for water pump	1	6	15	
Bolt on water pump cover	8	6	10	
Water drainage bolt	1	5	6	
Bolt of thermostat cover	3	6	10	

## Cylinder head and valve

Items	Qty.	Thread diameter mm	Torque N.m	Note
Bolt of M9 on cylinder head	6	9	5+15+90°+90°	Coat thread and base surface with oil
Bolt of M6 on cylinder head	2	6	10	
Bolt for bracket of camshaft	12	7	5+15	Coat thread and base surface with oil
Screw plug for swinging arm shaft	2	10	10	
Bolt of cylinder head cover	4	6	10	Coat contact surface of plate end with oil
Noise reduction bolt	1	6	10	

## Clutch and gearshift device

Items	Qty.	Thread diameter mm	Torque N.m	Note
Central nut for clutch	1	20	190	Coat nut with glue, knock side when it fastened
Pressing plate bolt for clutch	3	6	10	Coat thread and base surface with oil
Bolt for deviation locating plate	1	6	10	
Bolt for gear box cover	6	7	18	
Bolt for smaller flying sprocket wheel	1	10	50	Coat thread with Loctite 243
Bolt for heat exchanger between oil and water	4	6	10	Coat thread with Loctite
Bolt for right crankcase cover	11	7	20	

## Lubrication system

Bolt for oil bottom case	15	6	10	
Bolt for oil collection	7	6	10	

tray				
Bolt for primary filter	2	6	10	
Bolt for oil pump	3	6	10	
Bolt for sprocket wheel cover of oi pump	4	6	10	
Bolt for oil outlet tube/Oil absorption tube	2	6	10	
Bolt for oil nozzle	2	6	10	

## Magneto and starting clutch

Items	Qty.	Thread diameter mm	Torque N.m	Note
Fastening bolt for starting clutch	6	8	35	Coat bolt with Loctite
Bolt for rotor of magneto	1	14	150	
Bolt for stator of magneto	3	6	10	Coat bolt with Loctite
Fixing bolt for trigger	1	6	10	
Bolt for limiting plate of plate shaped gear	1	6	10	
Bolt for left crankcase cover	11	6	12	Coat thread with sealant

## Crankcase

Items	Qty.	Thread diameter mm	Torque N.m	Note
Bolt for shaft pad cover	2	7	17	
Bolt for shaft jacket of rear balancing shaft	1	9	15+120°	
Bolt 10mm for crankcase	6	10	10+80°	
Bolt 8mm for crankcase	10	8	5+80°	
Bolt 6mm for crankcase	7	6	10	

## Crankshaft, piston, cylinder body and balancing shaft

Items	Qty.	Thread diameter mm	Torque N.m	Note
Nut for cover of connective rod	4	8	33	Coat thread and base surface with oil
Check plate of balancing shaft/Bearing of main shaft	4	6	12	Coat thread with sealant

## Position for lubrication and sealing

### Engine

Material		Position	Note
Sealant	3-0115 Dow Corning	Contact surface of crankcase Gasket for cylinder head cover Combination surface of oil bottom case Contact surface of oil collective tray Contact surface of sprocket wheel cover for oil	
Oil in engine		Complete surface of inner and outer rotor of oil pump Complete surface for swinging arm shaft Working surface for swinging arm Sliding surface of rod end of valve rod Complete surface of timing chain Surface for journal of camshaft and the cam Inner surface of cylinder hole Outer surface of piston, piston pin's hole and groove of piston ring Outer surface of piston pin Complete surface of piston ring Complete surface of clutch friction plate Sliding surface of clutch pushing rod Rod part of gearshift spindle and turning plate Complete surface of double gear shaft Complete surface of starting clutch Complete surface of gearshift fork shaft Inner surface of shaft pad on bigger end of connective rod of crankshaft Inner hole for smaller end of connective rod for crankshaft Gear(Primary, crankcase, starting deceleration) Sliding surface of plate shaped gear Turning area of each bearing Surface for each o-ring Hole for camshaft on cylinder head	
Multi-functional lubricant		Seal ring for starting motor Seal ring for magneto sensor Sensor for crankshaft position	

	View window cap Oil gauge	
Degreaser	All the contact surface for sealing	

## 2. Maintenance

### Maintenance information

#### Summary

- Please lay motorcycle on horizontal ground before all the operations.

#### Tool

**Cap-shaped wrench for  
secondary oil filter**

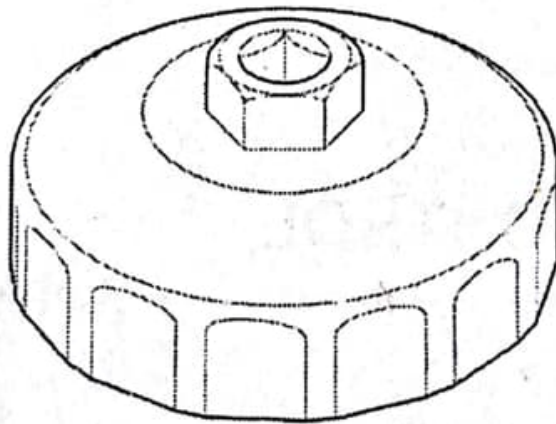

Cap-shaped wrench for secondary oil filter

## Specification for maintenance

Please inspect according to <Periodic Maintenance table> in User Manual.

I: Inspection, clean it up, adjust, lubricate or replace when it was necessary. C: Clean up. A: Adjust.

L: Lubricate.

The maintenance below need you know something about machinery. Some items (Especially with mark \* and \*\*), they may need more skill or tools and information.

Form list for periodic maintenance

Ref.No.	Period Items	X1000km	1	5	10	15	20	25	30
		Month	1	6	12	18	24	30	36
*1	Spark plug						R		
*2	Oil in engine		R	R	R	I	R	I	R
*3	Secondary oil filter		R	R	R	R	R	R	R
*4	Valve clearance						I		
*5	Coolant		I	I	I	I	R	I	I
*6	Cooling system			I	I	I	I	I	I
*8	Fuel tube			I	I	I	I	I	I
9	Breathing tube of crankcase			C	C	C	C	C	C
10	Clutch system		I	I	I	I	I	I	I

Caution : 1. More frequent maintenance is necessary in case usually drive under dusty or wet conditions.。

2. \*Means special tools, data or skill is necessary, which needs be done by Loncin dealer.

## Breathing tube of crankcase

Caution:

- When driving in rain or under full speed, when washed or oppositely put the motorcycle, the more maintenance is needed. Check the sediment in breathing tube by viewing its transparent part. Pull off plug [1] of cleaning tube for air filter, guide sediment into suitable container, the get tube plug in place once again.
- 
- 
- Remove fuel tank and firmly hold it.
- Check and confirm if there is crack, aging, damage or flexibility on waste gas tube [1] of crankcase.
- Replace waste gas tube for a new one if it is necessary.

- Re-assemble fuel tank.
- Diagram of supplement from Project team for complete motorcycle.
- 

## ■ Spark plug

- Remove fuel tank.
- Remove spark plug [1].
- *Caution:*
- *Before removing the spark plug, blow the surroundings of its base by air gun, meanwhile making sure there is not any dust dropped into combustion chamber.*
- Check and confirm if there is crack or damage on insulator, also confirm if there is damage, dirt or color changing on terminal, please replace the spark plug if it is necessary.
- Check spark plug:
  - Clean up the terminal of spark plug by its cleaner for it only or iron wire.
  - Check the clearance between central terminal and the side terminal by feeler gauge.
    - Clearance for spark plug: 0.80-0.90mm
    - In case it is necessary, get the side terminal bent to adjust the clearance.
    - Assemble spark plug and turn it to cylinder head, then turn it to given torque.
    - Torque: 12N·m
    - Assemble the fuel tank.

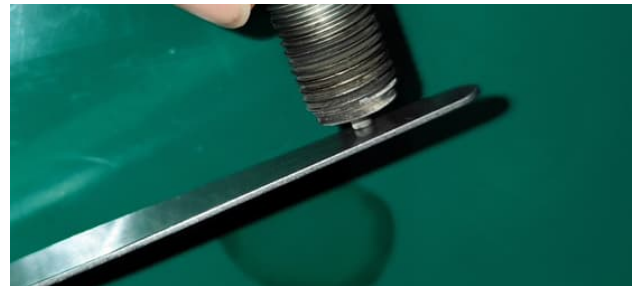

## ■ Valve clearance

- Inspection
- Caution:
- Please check and adjust valve clearance when the engine is cold (Under 35°C).
- Remove the parts below:
  - Cylinder head cover
  - View hole cap and o-ring.
- Turn the crankshaft clockwise by socket

spline wrench of T60, get the basic circle for camshaft of air intake/exhaust for left cylinder align to swinging arm of valve, the check each valve clearance when they are aligning.

- ○



- 
- λ Insert the feeler gauge with standard specification into basic circle of camshaft of swinging arm between air intake and exhaust valve on left cylinder, then check the clearance for 4 air valves for left cylinder and take them into

record. The clearance for air intake valve is: 0.11-0.20mm, the clearance for air exhaust valve is 0.26-0.35mm. Caution: When checking the clearance for air exhaust valve, please lift up the pressure relief valve.。

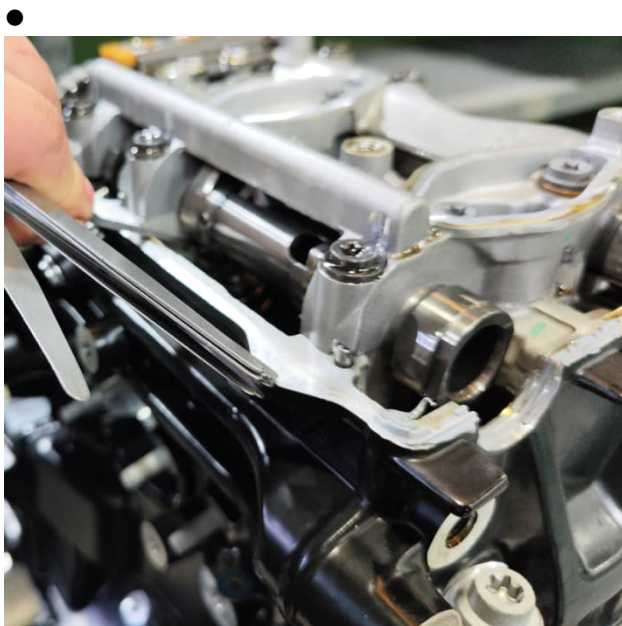

Under condition, keep turning crankshaft clockwise, until the basic circle of camshaft for

- λ Insert the feeler gauge with standard specification between journal of camshaft of air intake/exhaust valve and tappet, the check the clearance for 4 air valves for air intake and exhaust valve for right side cylinder and take them into record. The standard clearance for air intake valve is: 0.11-0.20mm. The standard clearance for exhaust valve is 0.26-0.35mm. Caution: When check clearance for air exhaust valve, please

- 
- air intake/exhaust of right side cylinder aligned to swinging arm of valve, then check each valve clearance when aligning.



- lift up the pressure relief valve.
- Caution: Take clearance for each valve into record for selection for washer when adjustment for valve is necessary.



- 
- 
- 

### ● Adjustment

- In case the valve clearance is out of range above, please remove the bracket of camshaft and remove it, then open swinging arm for valve, then absorb the adjustment washer for valve out by magnetive bar, replace the adjustment washer for valve for a suitable one then adjust the valve clearance into stipulated range, whose details is as below:

- 
- 
- 

- 1) Turn the crankshaft clockwise, until the hole of timing gear of crankshaft align to the lowest hole of bolt of water pump cap, meanwhile get scale mark of end surface of driven sprocket wheel of camshaft for air intake/exhaust valve parallel to installation surface of cylinder head cover and get the laser marking number upside down, insert positioning pin into lowest hole for bolt of water pump cover, the lock up crankshaft. At this moment, the engine

- 

- 
- 

is in the "Condition for Installation".

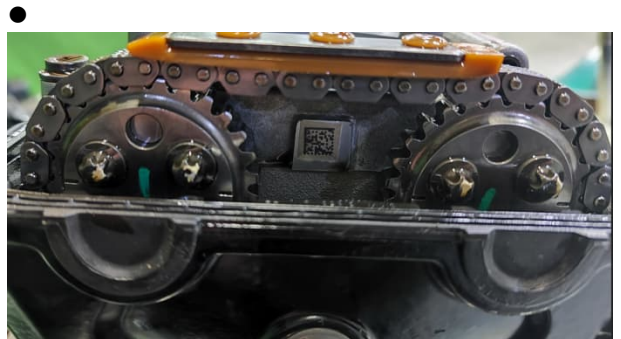

- 
- 
-



- Caution:
  - There are washers of 89 different thickness for selection, whose difference for thickness between adjacent two are 0.01mm ( 1.72-2.60mm)
  - Calculate thickness for new washer by

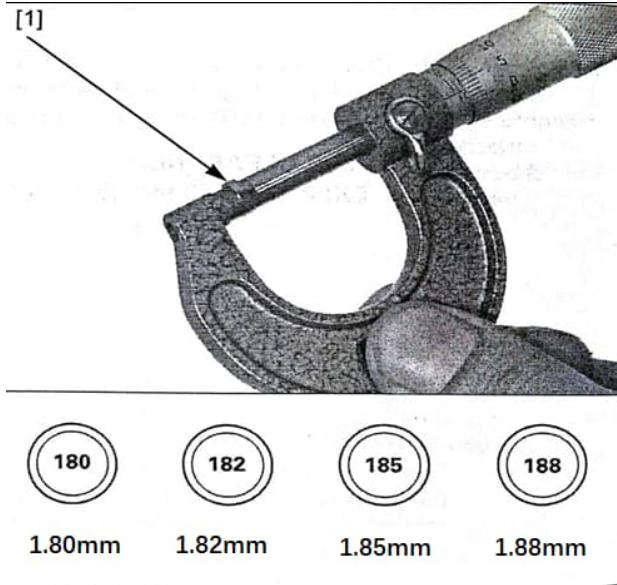

- Caution:
  - Measure by micro gauge to make sure the correct thickness of washer.
  - In case the calculated result is more than 2.6mm due to the carbon buildup, please trim the surface of valve base.
  - Please avoid washer dropping into crankcase of spark plug hole.
  - Mark up all the washers to make sure the correct re-assembly.
  - Take washer out by magnetive piece will be easier.
  - 5) Close the swingingarm, assemble camshafg and its bracket, then fasten it by bolt with fastening torque of 15N•m.

equality below:

- $A=(B-C)+D$
- A: Thickness for new washer
- B: Take valve clearance into record
- C: Fix the midpoint of valve clearance
- D: The thickness for removed washer

Caution: Coat journal with suitable lubricant before assembling camshaft.

- 6) Assemble upperguidingplate for chain with fastening torque of 10N.m Assemble hydraunlictensioner and its covering plate with fastening torque of 15N•m。
- 7) Finally turn and assemble crankshaft to left and right cylinder for timing by method above, then measure valve clearance once again.
- 8) Re-assemble cylinder head cover, view hole cap and bolt for water pump in place, please replace washer for the bolt for a new one.

## ■ Oil in engine

- Check oil level
- Put the motorcycle on horizontal ground and get main stand opened.
- Start engine and male it idly run until cooling fan begin working, then idly run for 1 minute.
- Stop engine and wait for a minute to make sure oil returned.
- Clean up surrounding of oil filling-up port.



- Make sure there is not any oil leaks.

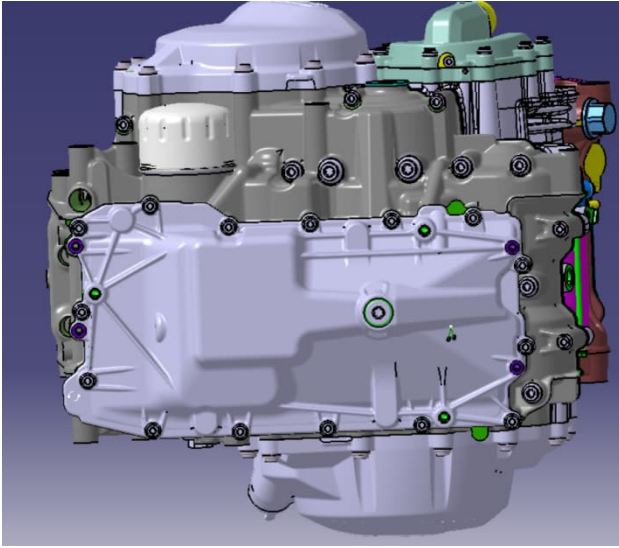

- 
- Secondary oil filter

- Drain off oil.
- Remove secondary oil filter [1] by special tool.

- Tool:



Confirm the tube joint of secondary oil filter and fasten it to given torque.

- Coat threaded part of new secondary oil filter [1] and o-ring with oil.
- Assemble secondary oil filter and

- [2] Cap-shaped wrench for secondary oil filter

- Torque: 28N·m

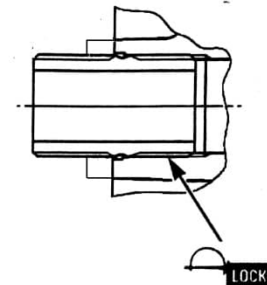

fasten it to given torque.

- Tool:
- [2] Cap-shaped wrench for oil filter
- Torque: 11 N·m

- Fill engine up with appointed oil until it is full.

- 

- 

- 

## ■ Engine idling

- Caution:
- When all engine maintenance are finished and confirmed they are in given range, then check idling problems.
- Before checking idling, inspect items below:
  - Malfunction indicating light is not flashing
  - Condition of spark plug
  - Condition for element of air filter
  - Throttle switch and free play for throttle lever.
- The idling malfunctions could be precisely checked only when engine is hot.
- Start engine, heat it to normal working temperature, then idly run it and check is idling.
- Check idling.
- Idling:  $1250 \pm 100$
- In case the idling is out of maintenance limit, please check the parts below:
  - Malfunction on engine end or air intake
  - Operation for idling control valve
  - In case the idling malfunction could not be fixed, please contact 4S station with authorization.

## ■ Clutch

- Check if there is distortion or damage of clutch cable. Lubricate it if it is necessary.

- Check free play of clutch lever and its end part.

- Free play: 10-20mm

- 

- The tiny adjustment could be done by the adjustor on clutch lever.

- Loosen locking nut [1], turn the adjustor according demands.

- Hold adjustor, meanwhile fastening locking nut.

- In case get passed line range of adjust, the precise free play could not be got, at this

moment, please adjust the main adjustor.

●

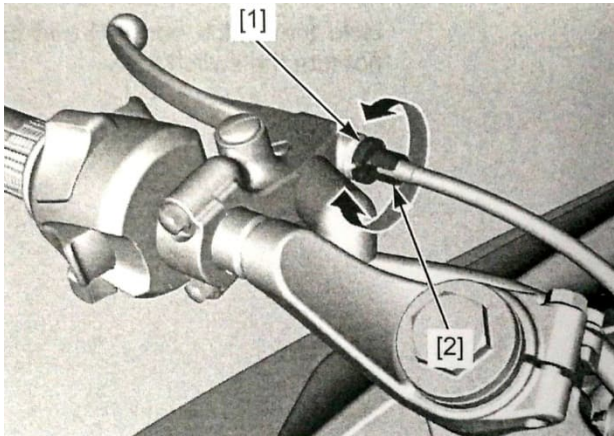

●  
●  
●

● Main adjustment is through adjusting the nut [1] on operation arm for clutch.

● Loosen locking nut [1], turn the adjustor according to demands.

● Hold adjustor, meanwhile fastening the

locking nut.

● In case failed to get correct free play of clutch, or the clutch is skidding when driving, please separate and check clutch.

●

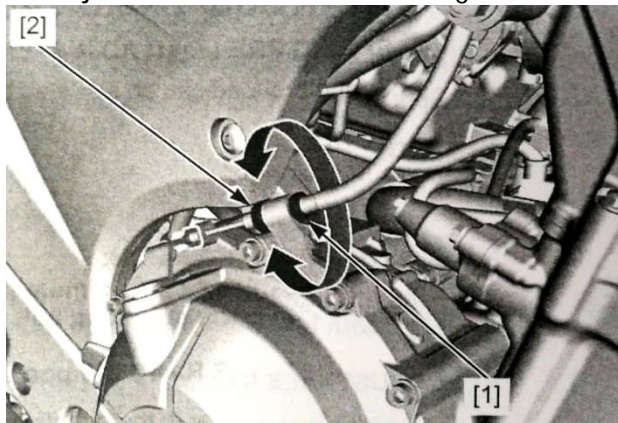

●

●

## ● 3. Cooling system

- Maintenance information
- Summary

### ● Warning

- Please don't remove the cover of heat radiator when the engine and radiator completely cooled down, otherwise the coolant may inject or splash out and get your injured.

●

- Ca  
uti  
on  
:

- The coolant with silicate solvent of anti-corrosion may accelerate the wear-out of seal ring on water pump and block up the passage of heat radiator.
- Use the running water may damage the engine
- Fill up the sub tank with coolant, except filling up of draining off, please don't remove the cover of heat radiator.
- The engine needn't be removed from frame when maintaining the cooling system.
- The coolant touches the painting surface is not allowed.
- Check the leakage when the cooling system was maintained by the tester of cooling system.
- Check by coolant temperature indicator/Water temperature sensor.
- Check the relay of cooling fan's controller.
- 

## ■ Cooling system specification

● Items		● Specification
● Coolant capacity	● Heat radiator and engine	● 1.5 L

	● Tank	● 0.38 L
● Relief pressure for heat radiator		● 120-150kPa
● Thermostat	● Initial temperature	● 83-87°C
	● Complete temperature	● 95°C
	● Valve rise	● Not smaller than 7mm
● Coolant we suggest		● GLYSANTIN G48-24
● Standard thickness for coolant		● Mixture with distilled water by ratio of ● 1:1

## ◆ Troubleshooting

- Too high the engine temperature
  - Malfunction in coolant temperature indicator/Water temperature sensor
  - The thermal valve failed to be opened
  - Malfunction on heat radiator's cover
  - Coolant is not enough
  - Passage, soft hose and water tube of heat radiator blocked up
  - Air got into circulation system
  - Malfunction in motor of cooling fan
  - Malfunction in relay of cooling fan's controller
  - Malfunction in water pump
- Too low the engine temperature
  - Malfunction in coolant temperature indicator/Water temperature sensor
  - The thermal valve was opened
  - Malfunction in relay of cooling fan's controller
- Coolant leakage
  - Defect on machinery structure of water pump
  - O-ring gets aged
  - Malfunction on cover of heat radiator
  - Gasket of cylinder head gets damaged or aged
  - The joint of soft hose or tube clamp get loose
  - Soft hose gets damaged or aged
  - Heat radiator is broken

- The cover of thermostat or tube joint of water pump's cover is flexible.
  - System procedure mode
- Diagram of supplement by Complete Motorcycle Project Team
-

## ■ Cooling system test

- Pressure test for heat radiator cover/System
  - Remove decorative component for right windshield of fuel tank.
  - Remove heat radiator cover [1]
  -
- 
- Get gasket of heat radiator cover wet, then assemble cover into testor [2].
  - Lay pressure on heat radiator cover by testor.◦
  - In case the heat radiator cover fails to keep pressure, or too high or low the pressure relief, please replace it.
  - The heat radiator cover must bear the given pressure at least 6 seconds.
  - Pressure for heat radiator cover:
    - 120-150 KPa
- Connect the testor to heat radiator.
  - Lay pressure on heat radiator, engine and soft hose by testor to check their air sealing performance.

- 

- 

- 

- 

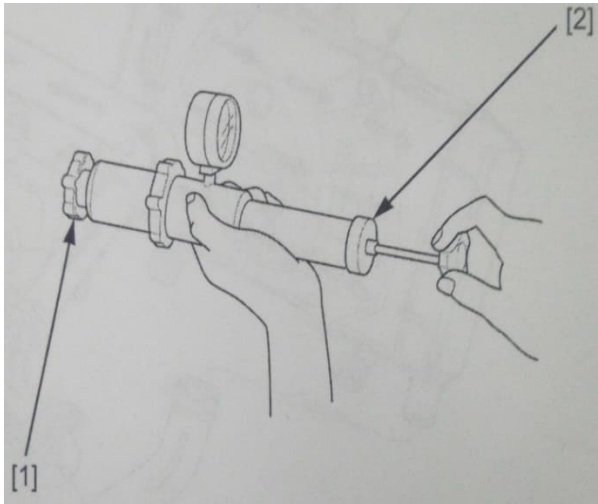

<ul style="list-style-type: none"><li>• C a u t i o n</li></ul>
---

- Overpressure may damage the cooling system, whose pressure shall not be more than 150Kpa.
- In case the system fails to bearing given pressure by at least 6 seconds, please repair it or replace parts.
- 

## ■ Coolant replacement

- Coolant replacement/Air exhaust
- Caution: When filling up the system or sub tank, or check the coolant level, please lay the motorcycle on horizontal ground and open the main stand.
- Remove the decorative component for right windshield of fuel tank.

- 
- Remove heat radiator cover [3], drain off
- the coolant.
- When replaced the flat washer for a new
- one, please assemble water drainage bolt
- in place.
- 
- 
- Fasten the water drainage bolt to correct
- Torque
- Remove water drainage bolt [1] for
- water pump and flat washer [2].

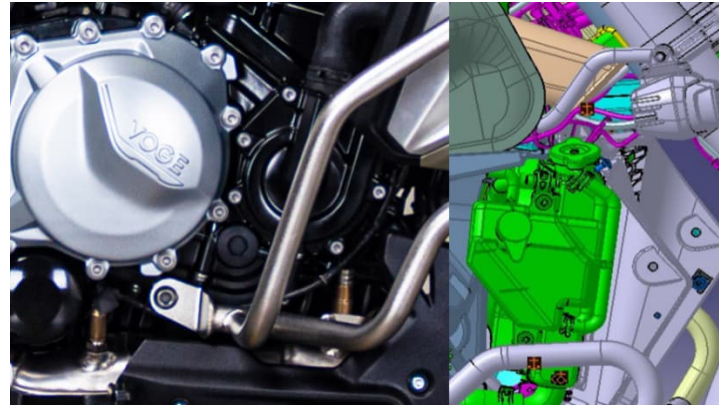

- Torque:
- Water drainage bolt for water pump:
- 6N . m
- Cut off soft hose [1] for siphon from
- heat radiator.
- Pull off siphon hose from its clamp.◦
- Put soft hose on lower place out of engine
- rim, then drain off coolant from storage
- 
- 
- Fill up with suggested coolant through
- filling-up port to neck [1] of cooling
- system.
- 
- 

- tank.
- Drain off coolant, the wash the internal
- of storage tank by water.
- Assemble soft hose into its clamp and
- heat radiator.

- 
- 
- 
- 
- 
- 
-



- 
- The coolant we suggest:
  - GLYSANTIN G48-24
  - Standard thickness for coolant:
  - Mixture with distilled water by ratio of 1:1
  - Exhaust air in system according to operation below:
- 1. Shift the engine to neutral gear.
  - Start engine and idly run it for 2-3 minutes.
- 2. Start and stop throttle by 3-4 times, exhaust all air in system.
- 3. Stop the engine, fill up with coolant if it is necessary.
- 4. Assemble heat radiator cover.
  - Fill up storage tank with coolant we suggest.
  - Assemble decorative component for right windshield of fuel tank.
- 

## ■ Thermostat

- Disassembly/Re-assembly
- Drain off coolant.
- Remove bolt [1] and thermostat cover [2].
- 
-

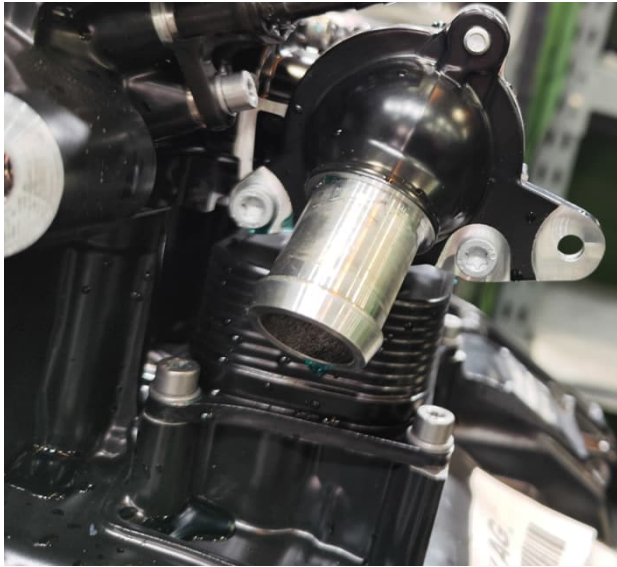

Remove thermal valve from thermostat base.

- The re-assembly is precisely opposite to disassembly.
- Torque:
  - Bolt on thermostat cover:
  - 10N·m
- Caution:
  - When re-assembling thermostat, the sharper end face outwards.

- When replacement finished, fill up with coolant.
- 

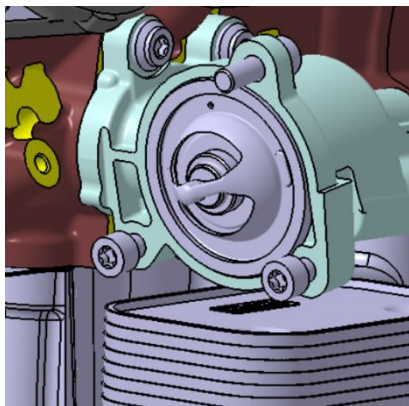

- 
- 

### ● Inspection/Test

- Check if there is damage of surface of thermostat [1].
  - In case the thermal valve is opening under room temperature, please replace.
- Check and confirm if there is damage on

- sealing ring[2], in case it is, please
- replace.



- 
- 
- *Caution:*
- *Wear heat proof gloves and suitably protect eyes, keep combustible material far apart electrical parts.*
- Don't let thermostat and thermometer [1] touch
- bottom, otherwise the result would be wrong.

- Heat water to working temperature by electric furnace and keep for 5 minutes.
- Suspend thermostat [2] in hot water to
- check its performance.
- 

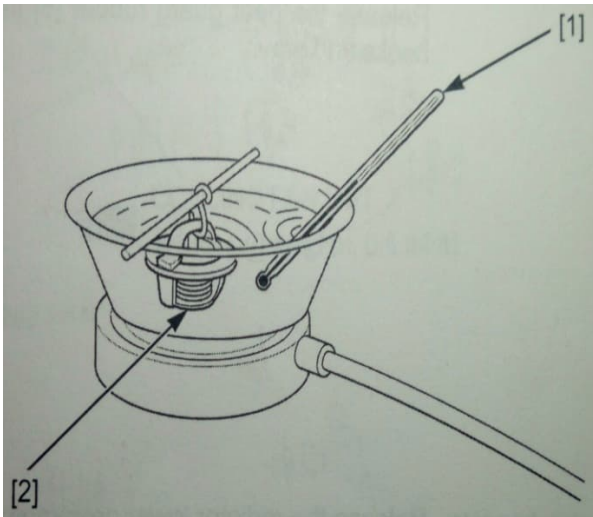

- Initial temperature of thermostat:
- 83-87°C (179-186°F)
- Complete height for valve:
- At 95°C (203°F) not lower than 7mm(0.27 in)
- In case the thermostat fails to get opened under given temperature, please replace.
-

## ■ Heat radiator/Cooling fan

- Disassembly/Re-assembly
- The Complete Motorcycle Project Team may make it according to actual

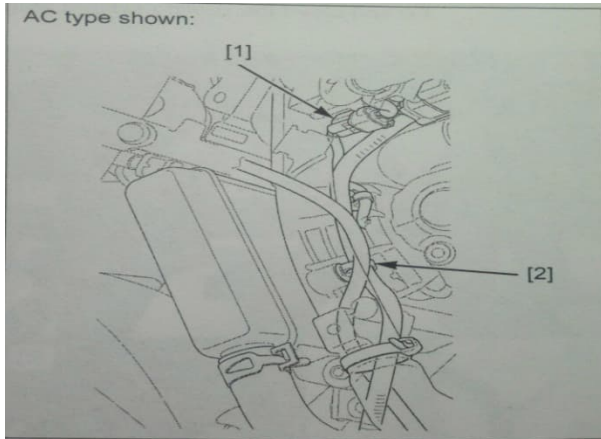

condition of KEL900.

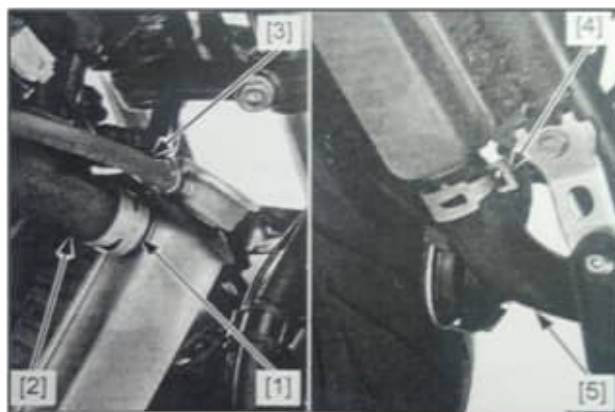
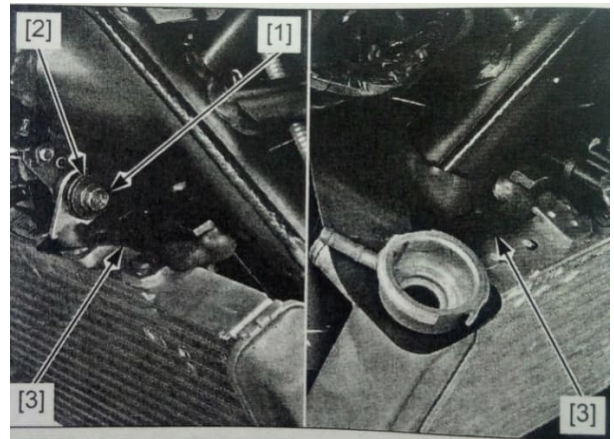

- Disassembly/Re-assembly
- The Complete Motorcycle Project Team may make it according to actual condition of
- KEL900.

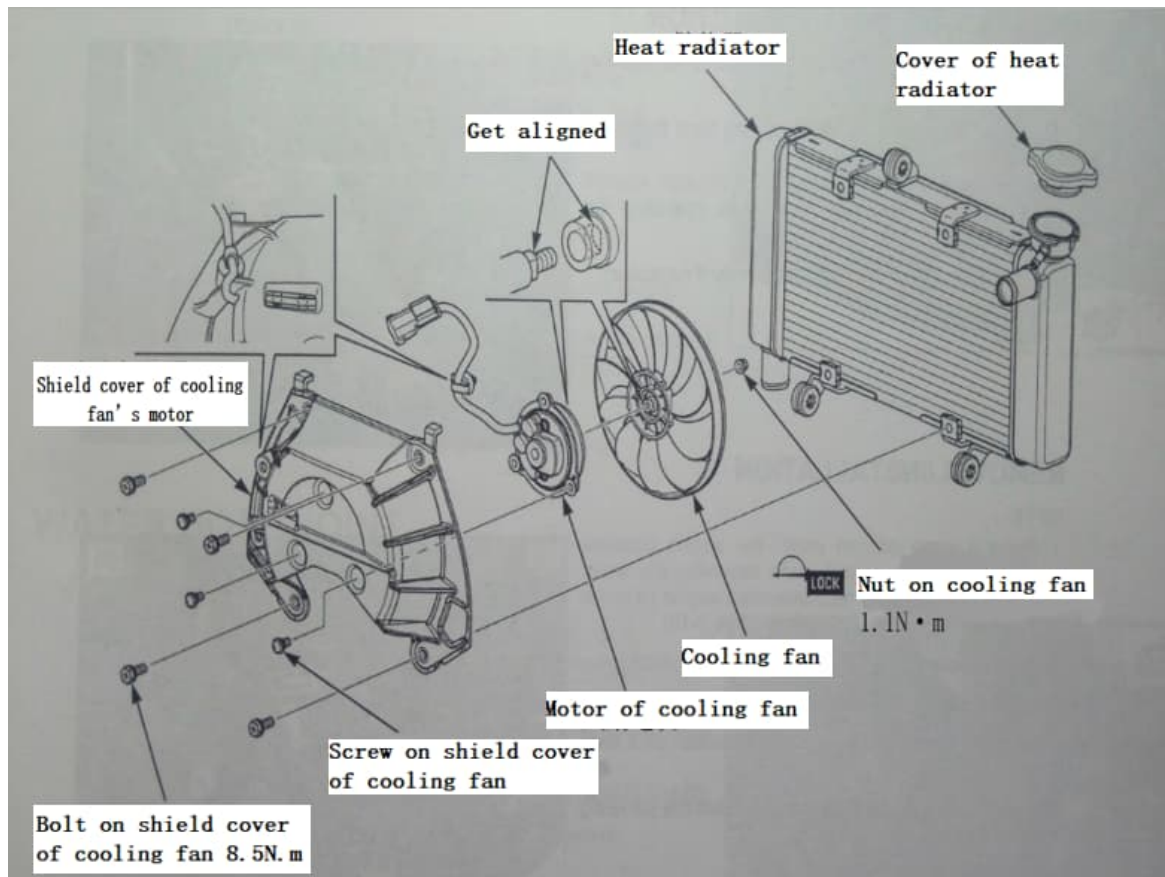

- 
- 

- Tank of heat radiator

- Disassembly/Re-assembly
- The Complete Motorcycle Project Team may make it according to actual condition of KEL900.

- 

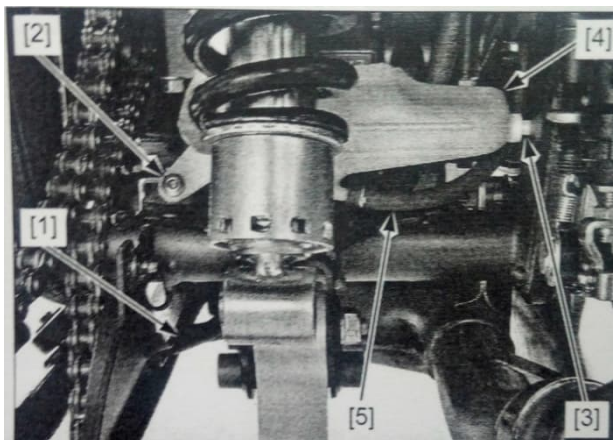

-

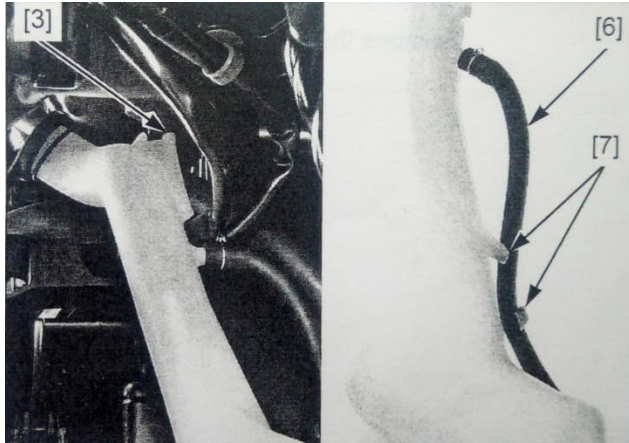

Water pump

- Sealing inspection for end surface
- Confirm if coolant leaks from overflow
- hole on water pump.
  - A few coolant leaks out is normal.
  - When starting engine, make sure there is not coolant leaking out.
  - Replace water pump for a new one if it is necessary.
  - 
  -
- Disassembly/Re-assembly
  - Caution:
  - Lay a clean oil tray under engine.
  - When removing water pump body there will be oil flow out. When re-assembled, fill up with appointed oil to given place (Refer to corresponding chapter of lubrication system).
  - 
  - Drain off coolant. ◦
  - Keep motorcycle upright on horizontal ground.
  - The Complete Motorcycle Project Team supplement the accessories need be removing.

- 



- Remove components below:
- Bolt [1] of water pump cover

- 



- 

- 

- 

- 

- Water pump cover [2]

- 

- 

-

- 
- 
- Remove gasket from water pump.
- Remove central bolt [1] from impeller
- 

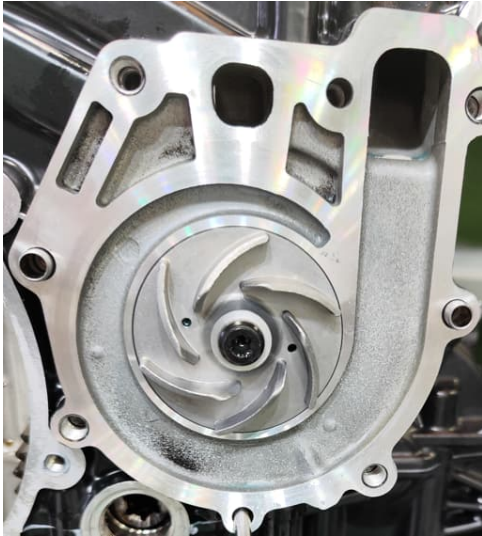

- Remove gasket [1] of water pump.

- The re-assembly is precisely opposite to disassembly.

- Torque:

- Central bolt for impeller of water pump:

- 12N·M

- Bolt for water pump cover:

- 10N·M

- Caution:

- Please don't break up the water pump body.

- Please replace water pump body/Gasket for a new one.

of water pump.

- Remove water pump [2] from crankcase.

- 

- 

- Please don't coat water pump body/Gasket with oil, make sure not any dirt adhesion.

- When assembling water pump body, press in balancing way without forced assembly.◦

- Check oil level.

- 

-

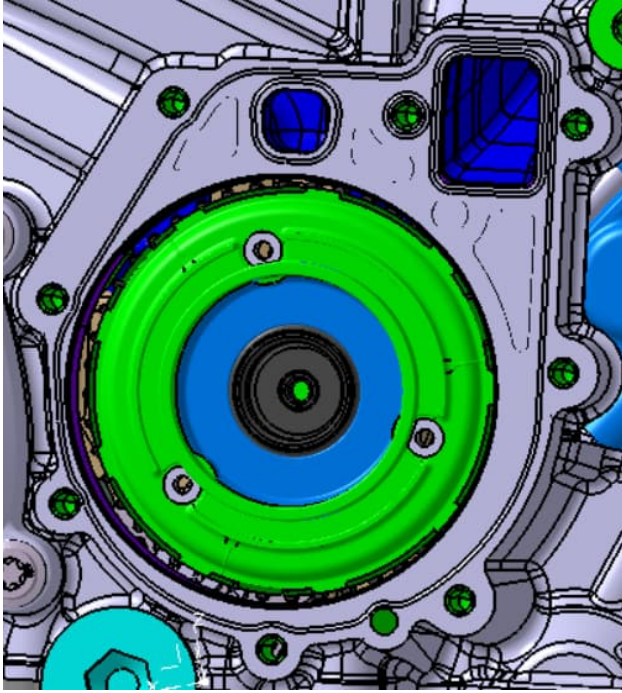

- Fill up system with coolant to full.

## ● 4. Lubrication system

### ■ Maintenance information

- Summary
- 

#### ● Warning

- Repeatedly touch the engine oil in long time may get skin cancer, but this kind of situation is rarely to be seen, unless your skin touches the engine oil every day, but we still you suggest you wash up your hands by soap and clean water.
- 
- When repairing the oil pump, we needn't remove the engine from frame.
- The pre-condition for all maintenance steps in this Chapter is drain off the oil in engine.
- When disassembling and re-assembling the oil pump, please don't let dust or dirt get into engine.
- Any part in oil pump passed the limit for maintenance, please replace the oil pump as a complete set.
- When the oil pump re-assembled, please check the oil leakage and correct oil pressure.
- Check the oil pressure indicator for engine and the EOP switch.

- Maintenance for injecting stream of piston.

- 
- 

- Tools

- Oil pressure gauge

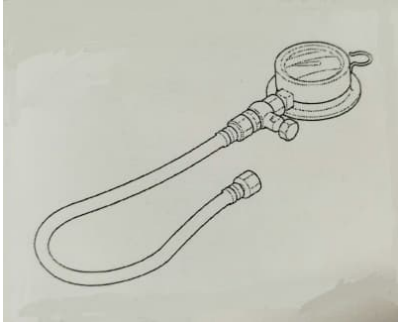

- 
- 

- Accessory for oil pressure gauge

-

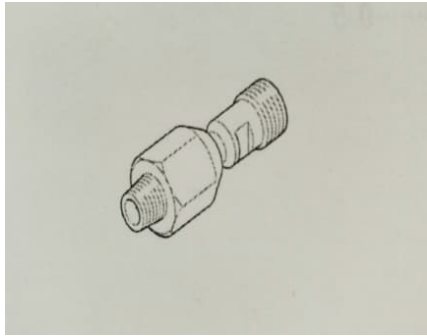

● Specification for lubrication system

● unit: mm

● Items		● Standard	● Maintenance limit
● Oil capacity	● After oil replaced	● 2.7 L	● —
	● When oil filter replaced	● 3.0 L	● —
	● When engine broke up	● 3.2 L	● —
● The oil we suggest		● Recommended oil: ● 5W-40 ● API quality grade: SGo or higher (Don't adopt the one with round label of API service for energy saving) ● JASO T903 standard: MA2 ● Viscosity: SAE 5W-40	● —
● Rotor of oil pump	● Clearance between tip of impeller	● 0.15	● 0.20
	● Middle clearance	● 0.15-0.21	● 0.35
	● Sides clearance	● 0.02-0.09	● 0.12

● Troubleshooting

- Too low the oil level

- Too heavy the oil consumption
- Oil leakage on external components
- Piston ring worn out or without assembling in place
- Cylinder worn out
- The seal of core shaft worn out
- Valve guiding tube worn out
  
- Too low the oil pressure
  - Too low the oil level
  - Oil filtering screen was blocked up
  - Oil leakage on internal components
  - Incorrect use of oil
  
- 0 oil pressure
  - Too low the oil level
  - Safety valve for oil pressure is seized up when getting open
  - Transmission chain of oil pump broke up
  - Teeth of driving and driven gear of oil pump broke up
  - Oil pump damaged
  - Oil leakage on internal components
  
- Too high the oil pressure
  - Safety valve of oil pressure gets closed
  - Oil filtering screen, oil returning hole and jet hole are blocked up
  - Incorrect use of oil
  
- Oil gets dirty
  - Didn't replace oil and filtering screen periodically
  - Piston ring gets damaged
  
- Oil emulsified
  - Cylinder head cover gets expanded and cracked
  - Leakage on coolant passage
  - Water gets into engine
  -

- Diagram for lubrication system

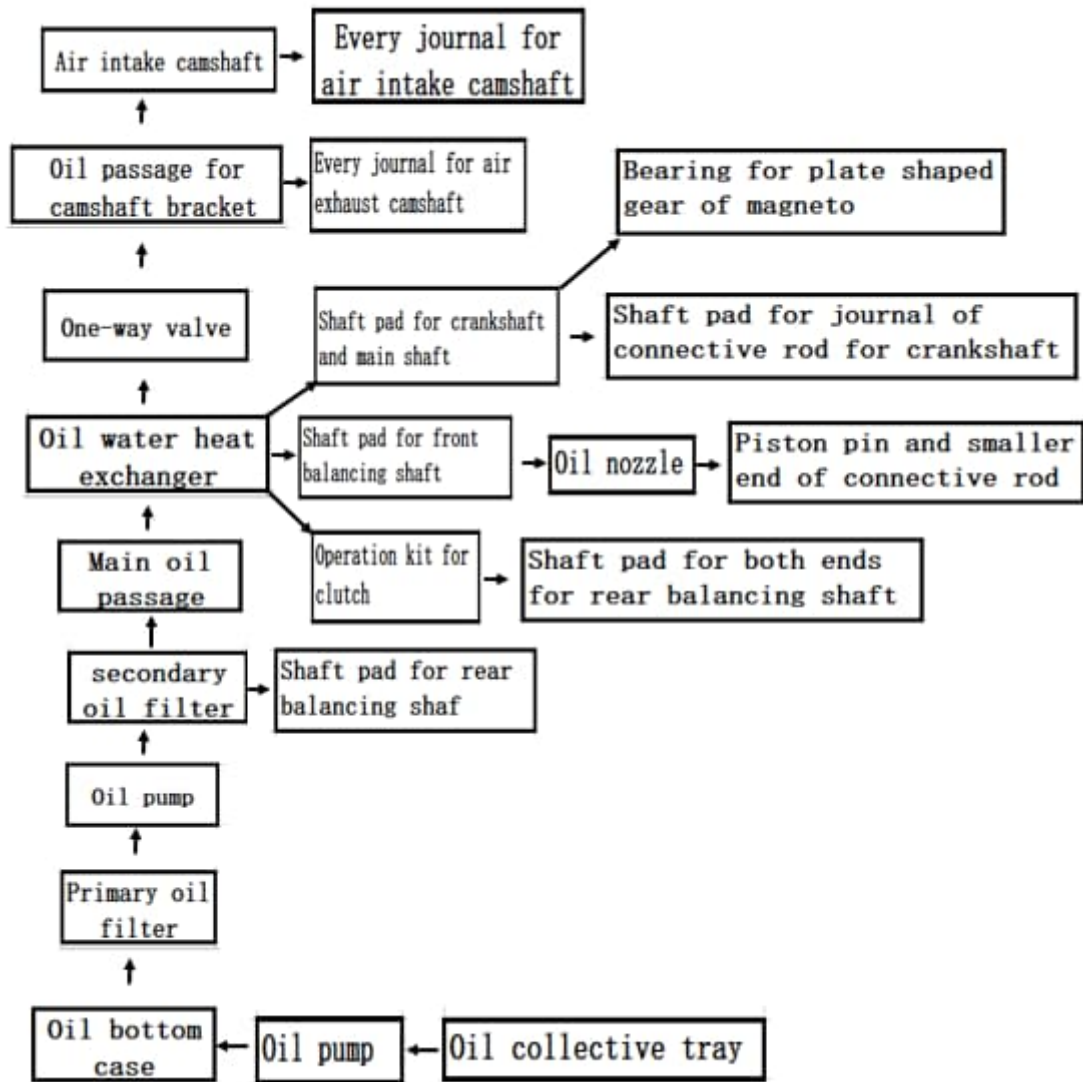

- 
- 
- 
- 
- 
- 
- 



## ■ Inspection for oil pressure

- Caution:
- Please remove screw plug for main oil

passage

- Assemble accessory [1] for oil pressure gauge into hole of screw hole.

- 
- 
- 
- 
- 
- 

- Connect pressure gauge [2] to accessory of gauge.

- 
- 
- 

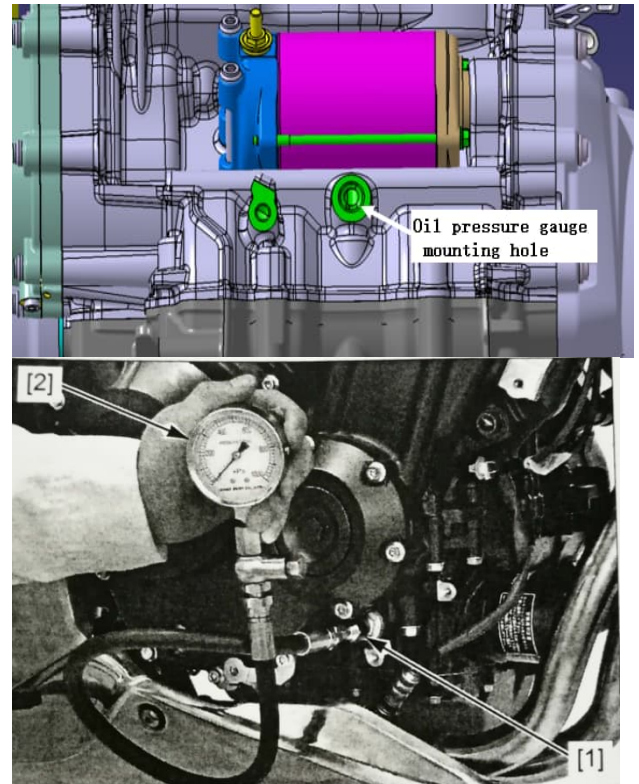

- Tool:

- Oil pressure gauge
- Accessory for oil pressure gauge.

- 

- Check oil level, fill up with oil if it is necessary.

- Heat engine to working temperature (About 80°C/176°F) , then accelerate the engine to rotation speed to 1250r/min, then read the oil pressure

- Standard:

- At 1250rpm/80°C, result is :230kPa

- 

- Stop the engine and remove the tools.

- Assemble sealing screw plug for main oil passage.

## ■ Oil pump

- Disassembly/Re-assembly

- Remove bolts on oil bottom case by diagonal sequence and remove oil bottom

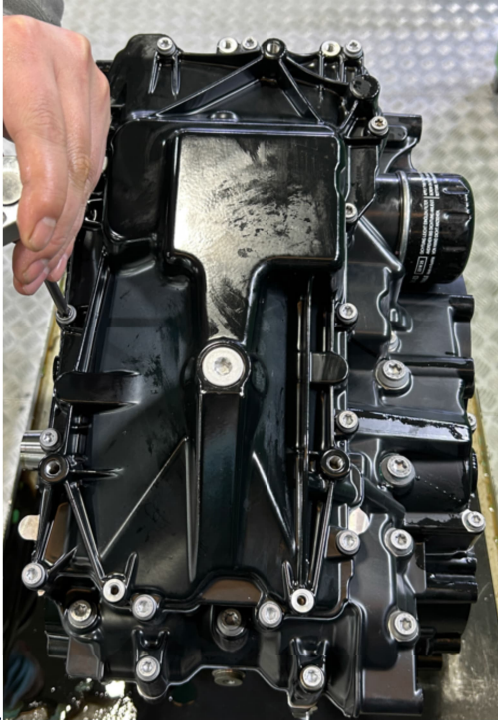

case.

- Remove bolt for primary oil filter and the filter itself.

- 
- 
- 
- 
- 
- 

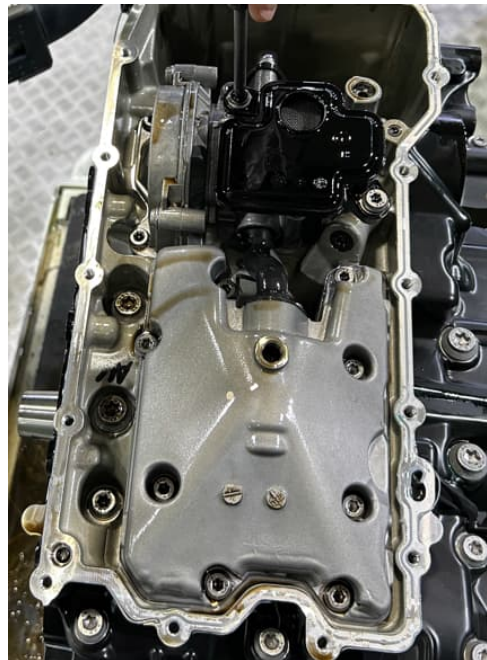

- 
- Remove sprocket wheel cover of oil pump and the wheel itself

- 
- 
- 
- 
- 
-



oil absorption tube, then remove the oil pump kit.



Remove bolt for oil pump and that for



The re-assembly is precisely opposite to disassembly.

Caution:

Coat sprocket wheel cover with sealant before re-assembly.

- 
- Disassembly/Re-assembly
- The disassembly and re-assembly for oil pump is shown as below:

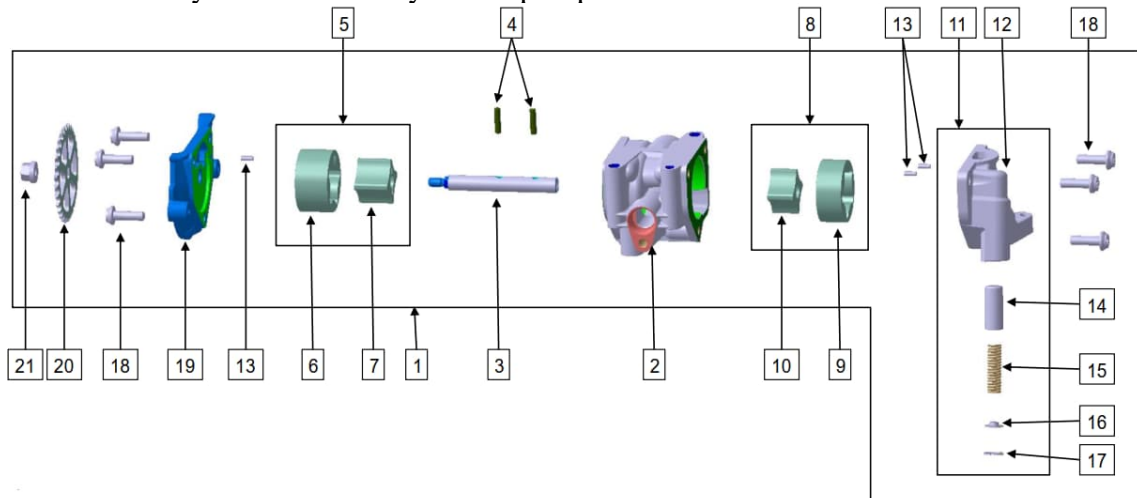

- 
- Inspection:
- Check driven sprocket wheel and chain for oil pump.
- Check if there is damage, wear-out, distortion or burn-out on parts below.
  - Oil pump shaft [3]
  - Positioning pin [4]
  - Oil absorption internal rotor [7]
  - Oil absorption external rotor [6]
  - Pressing oil internal rotor [10]
  - Pressing oil external rotor [9]
  - Oil absorption pump cover [19]
  - Oil absorption pump cover [11]
  - Oil pump case [2]
- Measure oil pump clearance according to specification of lubrication system.
- Any measured result passed maintenance limit, please replace the oil pump kit as a whole.

## ■ Pressure relief valve

- 
- Inspection
- Caution:
- Check working situation for pressure relief valve when oil pump removed.







- 
- The accessories need be assembled
- Once again shall be supplemented by
- project team



- 
- Fill up engine with suggested oil and check if there is any oil leaks.
- 







## ● 5 Cylinder head and valve

### ■ Maintenance information

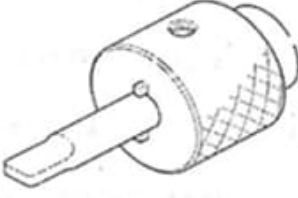
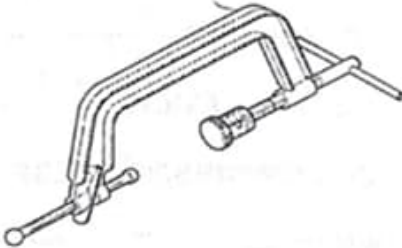
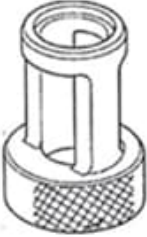
#### ● Summary

- This chapter includes the inspection and maintenance for cylinder head, camshaft and swinging arm.
- When repairing the camshaft, swinging arm and adjusting stud of tensioner, we needn't remove the engine from frame; But when repairing the cylinder head and valves, we need remove the engine from frame.
- When disassembling the components, mark up the removed parts for a correct re-assembly.
- Before checking, wash up all the removed parts by cleanser, then dry them up by compressed air.
- The lubricant on camshaft is got through the oil passage in cylinder head and its cover, in this case, before re-assembling the cylinder head and its cover, wash up their oil passage first.
- Please don't damage the contact surface when disassembling the cylinder head and its cover.

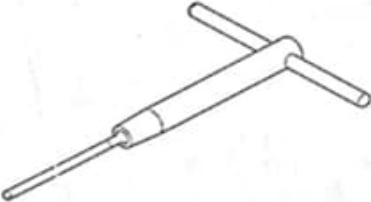
- 
- Tool
- 

<p><b>Compressed index attachment</b></p> 	<p><b>Tensioning device clamp B</b></p> 	<p><b>valve spring compressor</b></p> 
<p><b>Valve Spring Compression Fitting</b></p> 	<p><b>Valve conduit drive device 5.0mm</b></p> 	<p><b>Valve tube adjustment actuator</b></p> 
<p><b>Valve guide reamer 5.0mm</b></p> 	<p><b>Cutter base 5.0mm</b></p> 	<p><b>Seat cutter 32.5mm (IN45°)</b></p> 



## ● Specification for cylinder head/Valves

● Unit: mm

● Items		● Standard	● Maintenance limit	
● Cylinder pressure under electrical starting		● 450-600kPa	● —	
● Valve clearance		● Air inlet	● —	
		● Air exhaust	● —	
● Swingin g arm and its shaft	● Internal diameter of swing arm	● Inlet/Exhaust	● 8.013-8.028	● 8.033
	● External diameter of swingin g arm shaft	● Inlet/Exhaust	● 7.986-7.995	● 7.981
	● Clearance between swingin g arm and its shaft	● Inlet/Exhaust	● 0.018-0.042	● 0.047
● Camsha ft	● Protrusion height of cam	● Air inlet	● 36.226-36.288	● 36.206
		● Air exhaust	● 36.050-36.112	● 36.030
	● Clearance between journal and hole		● 0.020-0.056	● 0.07
	● Runout		● —	● 0.01

● Valve, guiding tube of valve	● Valve rod's diameter	● Air inlet	● 4.966-4.980	● 4.956
		● Air exhaust	● 4.956-4.970	● 4.946
	● Internal diameter of valve's guiding tube	● Inlet/Exhaust	● 5.000-5.012	● 5.04
	● Clearance between valve rod and its guiding tube	● Air inlet	● 0.02-0.046	● 0.07
		● Air exhaust	● 0.03-0.056	● 0.08
	● Guiding tube's height	● Inlet/Exhaust	● 12.60-13.20	● —
	● Width for gate line of base ring	● Air inlet	● 1.00-1.10	● 1.5
		● Air exhaust	● 1.10-1.20	● 1.6
	● Free length of valve spring		● 46.30	● 45.1
	● Flatness of cylinder head		● 0.05	● 0.10

## ■ Troubleshooting

- Malfunction at the top place of engine is usually bad for engine performance. We can find out these malfunctions by compression test, also we can find them by detective rod or stethoscope to know where the engine noise comes from, even can reach the top part of engine.
- In case the power output of engine is weak when it under low speed, please check if there is white smoke in beathing tube of crankcase. In case the soft hose is smoky, please check the jamming on piston ring.
- When engine is working under low speed, too low the compressing pressure, difficult starting or poor performance
- Valve
  - Incorrect adjustment for valve clearance
  - Valve burned out or got bent
  - Wrong valve timing
  - The valve spring got cracked
- Cylinder head
  - The gasket of cylinder head with leakage or damage
  - Cylinder head gets bow, twist or crack
  - Spark plug is flexible
- Cylinder, piston or piston ring worn out

- Compressing overpressure, overheat or cylinder knock
- Too much carbon buildup on piston head or in combustion chamber
- Smoky
- Cylinder head
  - Valve rod or guiding tube worn out
  - Sealing piece for valve rod damaged
- Cylinder, piston, or piston ring worn out
- Noisy
- Cylinder head
  - Incorrect adjustment for valve clearance
  - Valve gets jammed or its spring cracked
  - Camshaft worn out or damaged
  - Swinging arm and its shaft worn out
  - Swinging arm and valve rod's end worn out
  - Chain of cam gets flexible or worn out
  - Timing chain worn out
  - Teeth of cam's sprocket wheel worn out
- Cylinder, piston and piston ring worn out
- Poor idling
- Too low the compressing pressure in cylinder
- 
- 

## ● Cylinder compression test

- Idly heat engine to normal working temperature.
- Stop engine and remove spark plug.
- Assemble threaded part of cylinder pressure gauge [1] into spark plug hole.
- Tool:
- [2] Compressor gauge's accessories

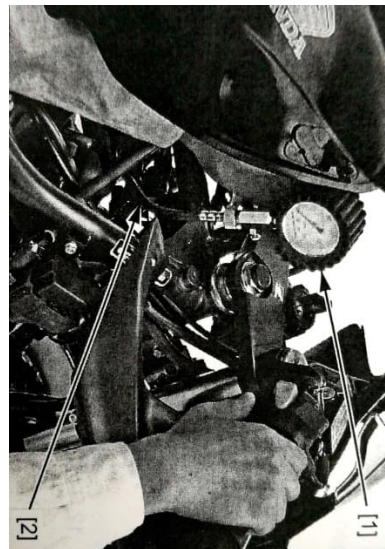

- Turn the ignition switch to "On",
- Shift to neutral gear.
- Keep full throttle, start engine until pressure gauge not rise any more.
- The highest data usually may keep for 4-7 seconds.
- Compression pressure:
- At 300rpm, 450-600kPa
- Analysis for low pressure:
- Leakage at cylinder head gasket.
- Improper valve clearance adjustment

- Valve leaks
- Piston ring or cylinder wear out
  - Analysis for high pressure:
- Carbon buildup in combustion chamber or piston top.

## ● Cylinder head cover

### ● Disassembly/Re-assembly

#### ● Caution:

- Repair cylinder head cover needn't remove engine from frame.

- 
- The accessories need be removed shall supplement by project team

- 1.Remove fuel tank.

- Remove secondary air suppelemntarytube[2]

- 2.Remove parts below:

- Remove breathing tube [3]

- Remove plug [1] for secondary air suppelemnt

- Fuel evaporation control system [4] [5]

- 3.Remove bolt [1], locating plate for clutch cable, then remove the cable [4]

from its lug [3].

- 8.Remove clutch cable from frame.

- 4.Loosen locking nut A [1] from adjustor of throttle cable and the adjustor itself [2], then loosen and remove throttle cable [3] from throttle drum and cable bracket.

- 10.Remove installation bolt on heat radiator.

- 4.Loosen adjustor B [4] for throttle cable, then loosen and remove cable [5] from throttle drum and cable bracket.

- 11.Remove bolt [6] and

- wire joint [7] for braking

- 9.Removethrottle cable from frame.

- 12.Remove brake tube [9] from 2 wire clips [2], then remove the clips from frame.

- 5.Fuel evaporation system: Remove installation bolt [1] of carbon canister and washer [2], then remove the carbon canister [3].

- 

.

- 14.Fuel evaporation system: Remove controlling solenoid valve for evaporation and emission from frame.

- 13.Remove bolt [4] and connective wire

- 6.Loosen overflow tube [2] from tube

side of frame.

- clamp[1].

- 7.Remove rubber plate [3] at place of overflow tube, then put it on the right

- 

- 

- 

- 

- *Caution:*

- *To avoid runout for cylinder head*

*cover, please fix it by adhesive tape.*

- Remove bolt [1] on cylinder head cover.

- Remove the cylinder head cover [2] from cylinder head.

-

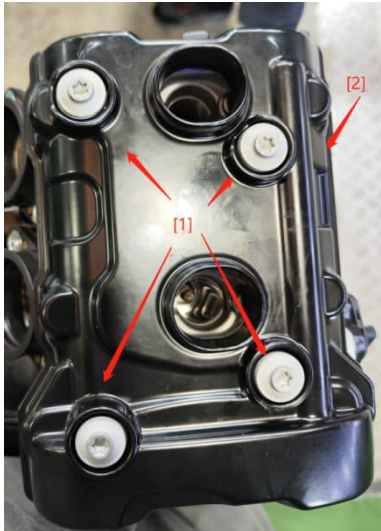

- Remove gasket [1] from cylinder head, then remove seal ring [2] of ignition coil from cylinder head.

- The re-assembly is precisely opposite to
- Disassembly.
  - Torque:
  - Bolt on cylinder head cover: 10N·m
  - Caution:
- Replace gasket for cylinder head and seal ring for ignition coil for a new one.
- Before re-assemble gasket for cylinder head, please coat it with Sealant of Dow Corning.

## ● Camshaft

- Caution:
- When repairing camshaft, it needn't remove engine from frame.
  - Remove cylinder head cover.
  - Make sure the piston of cylinder 1<sup>st</sup> is at upper stopping point of compression
- 

- When re-assembling, please assemble the groove on gasket of cylinder head cover to corresponding protrusion on cylinder head.

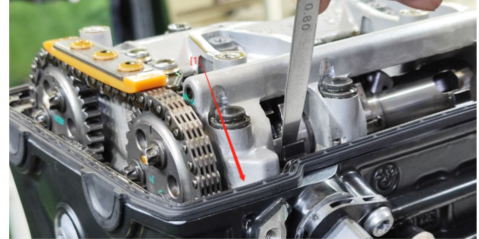

- Adjust as below:
  - Free play for throttle cable
  - Free play for clutch lever

- 
- 
- 
- 
- 

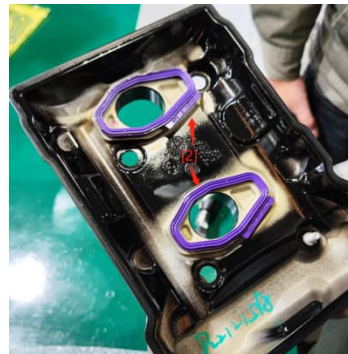

- 
- 

stroke.

- Remove covering plate [1] of
- tensioner, then remove the hydraulic
- tensioner.

- 
- 

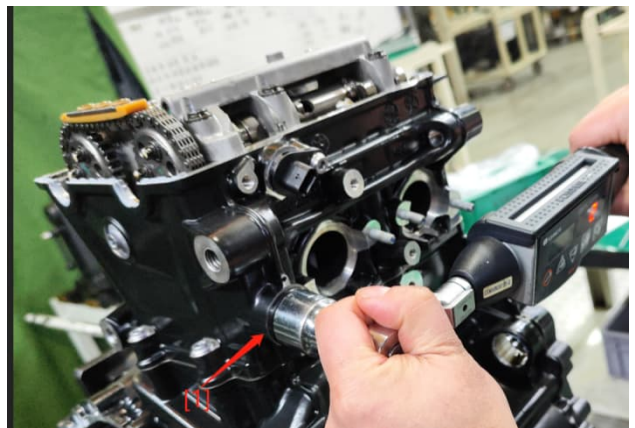



- Lift up swinging arm [1]。
- Remove adjustive shim [2] for valve.
- Caution:
- Please don't let adjusting shim drop inton crankcase.
- Mark up adjustive shim for a correct re-assembly.

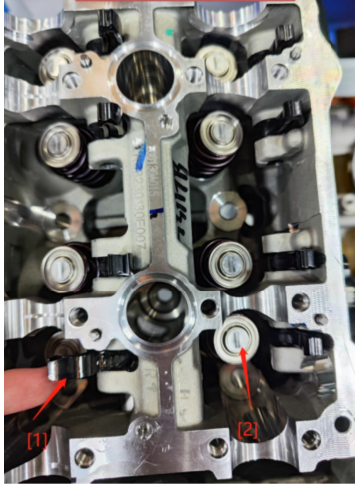

- Take out shim by tweezers or magnet would be easier.
- 
- 
- Inspection
- 

- Check and confirm if there is damage, wear-out, distortion, burn-out or oil passage
- blocking up on parts below.
  - Sprocket wheel of cam/camshaft
  - Camshaft bracket/Positioning pin
  - Pressure plate for chain of cam
- Measure each part according to specifications of cylinder head/valves.
- Camshaft runout
- Fix both ends of camshaft by V-shaped piece, then measure its runout by micrometer.
- Maintenance limit: 0.01mm
- 
- 
- 
- 
- 
- 
- 
- 
- Oil clearance for camshaft
- Wipe up oil on camshaft, its bracket and cylinder head.
  - Assemble camshaft onto cylinder head.
- Get marking line on end surface on driven sprocket wheel for air intake/exhaust camshaft paraller to installation surface of cylinder head cover, then put laser marking number upside down as picture shows.
- 
-



- Torque: 15N·m
- 
- 
- Remove camshaft bracket, then measure each width for gap gauge of plastic line.
- The widest place is the oil clearance.
- Maintenance limit: 0.10mm

- When it passed maintenance limit, replace the camshaft for a new one and measure oil clearance once again.
- In case the oil clearance passed maintenance limit, replace the camshaft bracket and cylinder as a complete kit.
- 

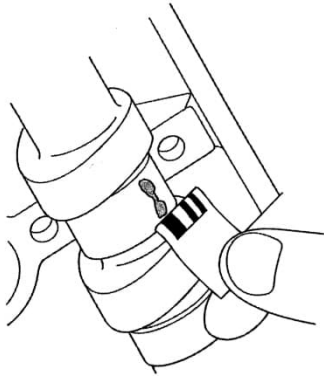

### Re-assembly

- 
- *Caution: When turning the crankshaft, please don't press-fit chain of cam into timing sprocket wheel.*
- Turn the crankshaft clockwise, align positioning hole on primary driving gear to bolt hole at the lowest place of water pump cap.

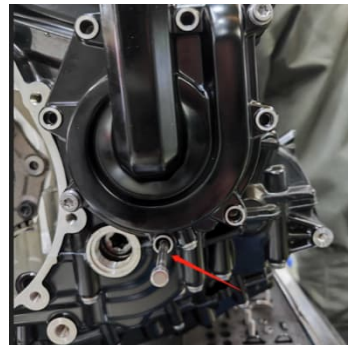

- 
- 
- 
- 
- *Caution: Please don't let adjustable shim for valve drop into crankcase.*
- Assemble adjustable shim [1] for valve back to original place on base ring of



- There is

- valve in turn.
- Lay down swinging arm shaft [2].
- 
- identification for camshaft of air intake/Exhaust:
- Pressure reduction device without starting: Air intake camshaft
- Pressure reduction device [1] with starting: Air exhaust camshaft
- 
-









- 
- Assemble sealing screw plug [1] for swinging arm shaft , please replace gasket for a new one.
- Fasten sealing screw plug of swinging
- 

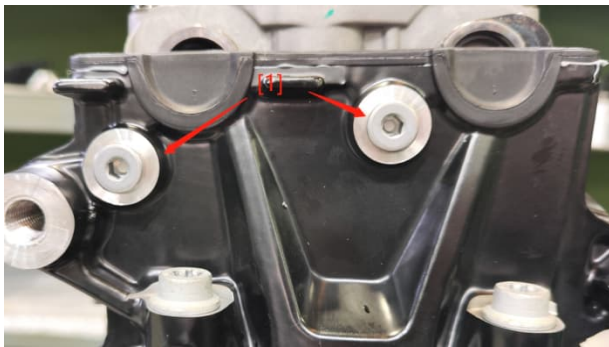

Inspection

- arm shaft to given torque.
- Torque: 15N·m
- Re-assemble camshaft.
- 
- Check and confirm if there is damage, wear-out, distortion, burn-out or oil passage blocking on parts below.
- Swinging arm
- Swinging arm shaft
- Measure each part and their clearance according to specification of cylinder head/valves.
- Any parts passed maintenance limit, please replace.
- 
- 

## ● Cylinder head

- Removal
- Remove parts below in turn:
  - Air filter
  - Throttle valve body
  - Engine
  - Heat radiator
- Water pipe of circulation
- Cylinder head cover
- Upper guiding plate for chain
- Camshaft bracket
- Air intake/exhaust camshaft
- 
-

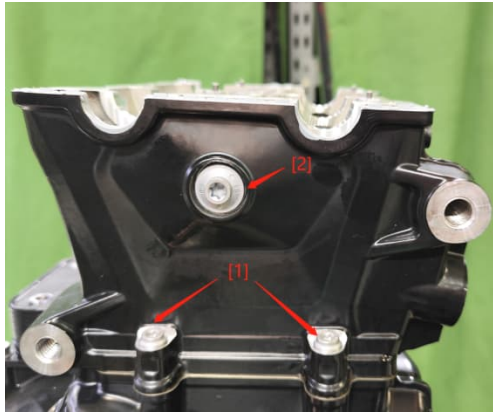

Rem

Remove bolt [1] of M6, remove noise

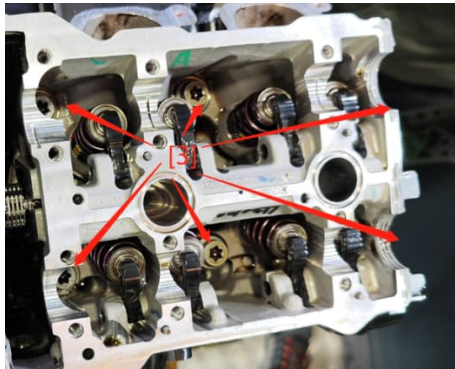

- 
- 
- 
- 
- 
- 
- 
- 



Br

Break up

- Remove parts below:
- 
- 
- 

- Mark up each parts when disassembly
- for a easy re-assembly.
- Remove valve compression tools and
- parts below:
- Upper base ring [1] for valve spring

- reduction bolt kit [2].
- Alternatively loose cylinder head
- bolt [3] of M9 by 2-3 times, then
- remove the bolt.
  - Remove cylinder head.
  - Caution:
- Fix chain of cam by hook to avoid dropping into crankcase.
- Heavily knock cylinder head is not allowed, don't damage contact surface by lever bar for prying up.

- 
- 
- Remove gasket [1] of cylinder head.
- 
- 
- 
- 
- 
- 
- 
- 

- Spark plug
- Water temperature sensor
  - Caution: Please don't heavily compress valve spring for permanent distortion when disassembling.
- Remove valve clip by the tools for
- it only.
  - Tools:
  - Compression tool for valve spring
- Compression accessory for valve
- spring
  - Valve spring [2]
  - Valve[3]
  - Oil shield cover[4]
  - Spring base [5] for valve
    - Please don't damage contact surface between cylinder head and crankcase body also surface of valve base.

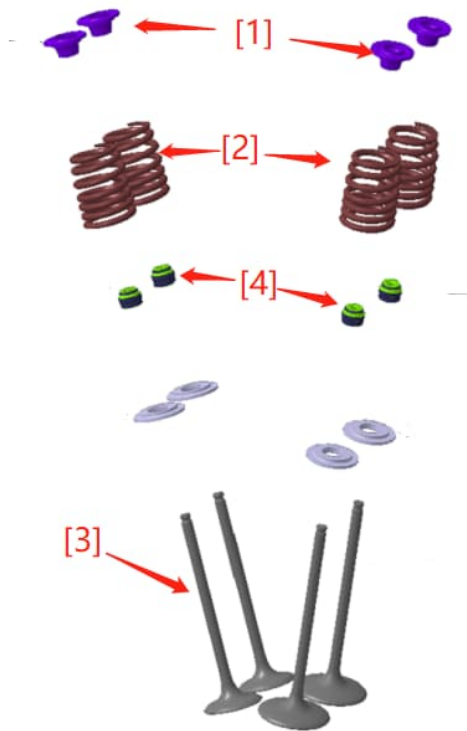

Please clean up carbon buildup in combustion chamber

- and surface of gasket
- for cylinder head.
  - Inspection
  - Check if there is damage, wear-out, distortion, burn-out or oil passage blocking on
  - parts below.
    - Cylinder head
    - Valve spring
    - Valve
    - Guiding tube of valve
    - Guiding plate/Tensioning plate for chain
  - Measure each part and clearance according to specification of cylinder head/valve
  - Any part passed maintenance limit, please replace.
  - Clean up carbon buildup inside guiding tube by reamer before measuring.
  - Please refer to inspection for valve base.
  - Replacement for guiding tube of valve
    - Break down cylinder head
    - Put new guiding tube of valve in freezer
    - for an hour.
    - Caution:
      - Please wear heat insulation glove for avoid scald when operating hot cylinder head.
      - Please don't heat cylinder head by fire, otherwise it may distort.
      - Heat cylinder head to 130-140°C by baking oven. Ensure the suitable temperature for heating cylinder head by thermal indicating
    - bar, which could be bought from shop for welding tools.
      - Hold cylinder head, push guiding tube and its clamp out of cylinder head from side of combustion chamber.
      - Tool:
        - Guiding tube driver, 5.0mm
    - Take new guiding tube [1] of valve from freezer.
    - When cylinder head is still hot, assemble new guiding tube from side of camshaft, until its exposing length reached stipulation.
      - Tool:
        -

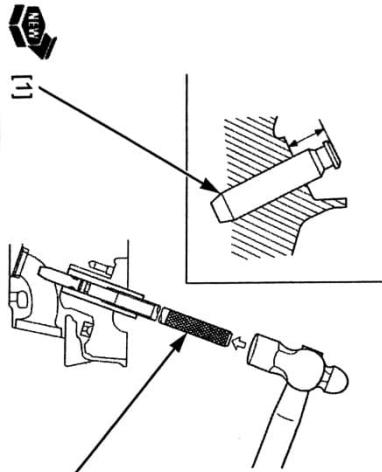

[2] Driver for adjustment guiding tube of

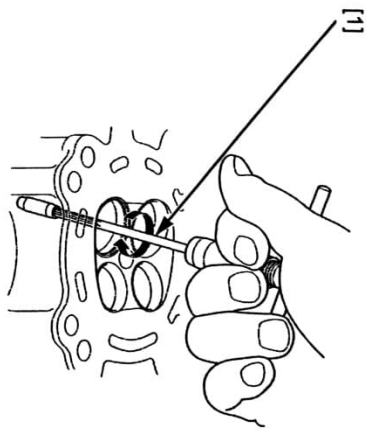

When reamer

- is working, please don't let
  - Inspection and trim for valve base
  - Inspection
  - Break down cylinder head.
- Totally clean up carbon buildup for air intake/exhaust valve.
- Coat each valve with a thin layer of red lead.
  - Slightly knock valve by hand grinding tools [1] to direction of valve base, check contact situation of valve base without turning valve.
- 
- Remove valve to check width for each surface of valve base.
- The width of contact surface for valve base shall be within stipulation, while

valve.

- Stipulation: Intake/Exhaust : 12.60-13.20mm
- 
- Requirement for re-assembly:
- Mark up depth for guiding tube by marker
- pen.
  - Adjust depth to correct by driver of guiding tube.
  - Get cylinder head cooled down to room temperature.
- Adjust new guiding tube by reamer when
- re-assembled.
  - 
  - Caution:
  - 
  - it raise up or get inclining inside of
  - guiding tube.
    - During this operation, please use lubricant for cutting.
    - Insert reamer from side of combustion chamber of cylinder and always turn the reamer clockwise.
    - Tool:
      - Guiding tube reamer, 5.0mm
- Totally clean up cylinder head to erase
- metal chips after reamer worked, them
- trim the valve base.
  - 
  - 
  - 
  -
- surrounding of valve base shall be smooth and flat.
- Standard: Intake 1.00-1.10mm Exhaust 1.10-1.20mm
- Maintenance limit : Intake 1.5mm Exhaust 1.6mm



- 3、 Then use internal milling cutter of intake 52°/exhaust 56.85°internal milling cutter , cut off ring belt area by 1/4 on bottom part of working surface of valve base.
- 4、 Then use trimming cutter of intake 45°/exhaust 50°trimming cutter , grind valve base to suitable width.
  - Make sure all the rough and irregular surface on valve base are grinded off.
  - 5、 When valve base was grinded, coat valve surface with abrasive, then slightly grind the valve.
    - Caution:
    - Powfully grind may lead to valve base distort or damage.
    - Frequently change angle of grinding tools can prevent uneven grinding.
    - Don't let the abrasive get to place between valve rod and guiding tube.
      - When grinded, please wash up the residual abrasive on cylinder head and valve, then check once again the contact surface of valve base.

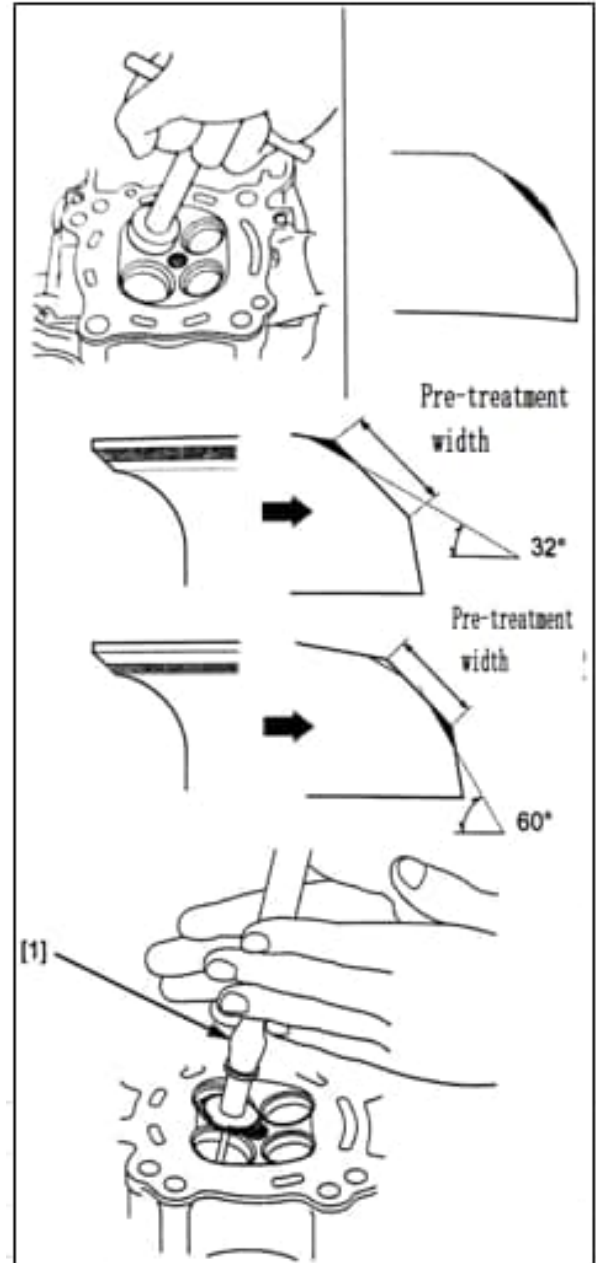

- 
- 
- Re-assembly

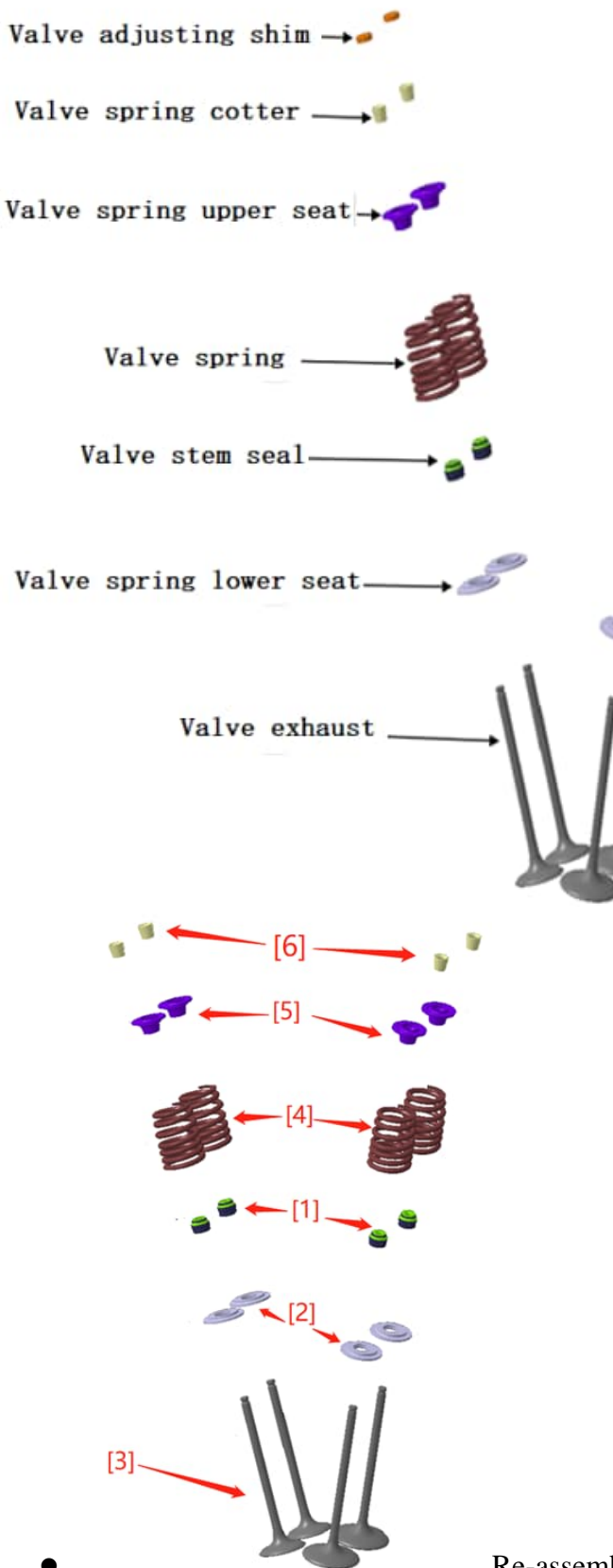

- Wash cylinder head kit by cleanser, then
- blow all the oil passages by compressed
- air.
  - Lubricate new oil shield cover [1] by oil.
- Re-assemble lower valve spring base [2]
- and oil shield cover.
- Lubricate sliding area of valve rod and
- rod end by oil.
  - Insert valve [3] into guiding tube, meanwhile slowly turning valve to avoid damage on oil shield cover.
- Re-assemble valve spring [4], get the side
- with bigger inner diameter face to
- combustion chamber.
- Re-assemble base ring [5] of upper valve
- spring [5].
  - 
  -

- 
- Re-assemble valve clip [6] by tools for this only.
- To avoid performance loss of spring, please don't heavily compress.
- Tools:
- Compression tool for valve spring
- Accessory for compression tool of valve spring

- 
- Hold cylinder head on working bench to avoid damage on valves.
- Put suitable tool [1] into guiding tube[2].
- Slightly knock to stably re-assemble lock clip.
- Re-assemble parts below:
  - Water temperature sensor
  - Spark plug
- 
- Re-assembly
- Erase dirt on contact surface of cylinder.
- *Caution: Please prevent dust or dirt dropping into cylinder.*
- 
- Re-assemble new gasket [1] into cylinder head.



- Get timing chain through cylinder head, assemble cylinder head onto crankcase.
- Totally clean up threaded part of connective bolt (M9) and base surface, then wipe it up.
- Coat oil for engine on thread part of seal bolt (M9) for cylinder head and base surface.
- Alternatively assemble seal bolt (M9) [2]
  - Camshaft for air intake/exhaust
  - Camshaft bracket
  - Upper guiding plate for chain
  - Cylinder head cover

## - Tensioner and its covering plate

- Disassembly/Re-assembly
- Caution:
  - The maintenance for tensioner and its covering plate needn't remove engine from

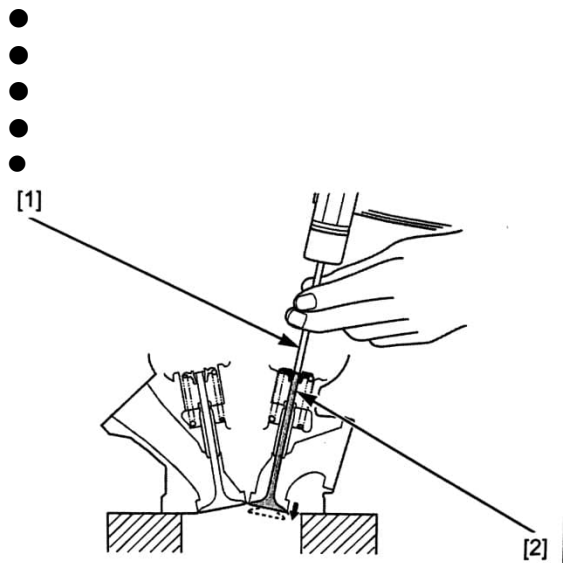

- 
- for cylinder head by 2-3 times, then
- fasten to given torque.
  - Torque:  $5\text{N}\cdot\text{m} + 10\text{N}\cdot\text{m} + 90^\circ + 90^\circ$
  - Re-assemble and fasten cylinder head bolt (M6) [3]. Torque:  $10\text{N}\cdot\text{m}$
  - Re-assemble parts below:
- 
- 

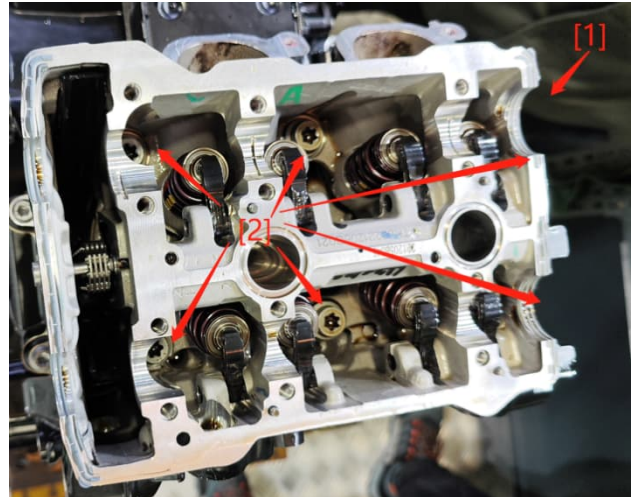

- frame.
- Remove covering plate [1] of tensioner and the hydraulic tensioner [2].

- Caution:
- When hydraulic tensioner was removed, please don't turn or move crankshaft and camshaft.



The re-assembly is precisely opposite to disassembly.

- Caution:
- Replace seal ring for a new one. Coat seal ring with lubricant of MP3 before re-assembling.

### Inspection

- Check operation performance for tensioner back without jamming.
- [1].
- Press by hand, obviously feel its bounce



### - Timing chain/Sprocket

- Removal
- Remove the parts below:
- Cylinder head
- Water pump kit
- 
- Remove timing double gear [1] from
- 

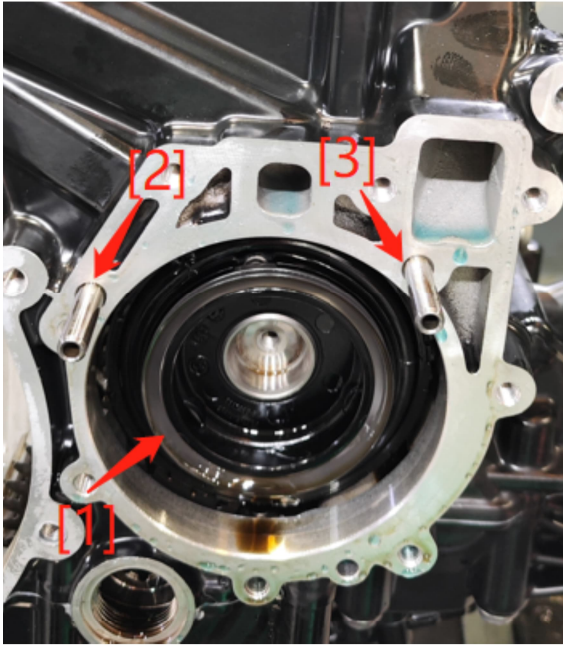

Re



### Inspection

- Check and confirm if there is scratch, damage, wear-out or distortion on parts below, in case it is, please replace.
- Timing chain
- Tensioning plate for chain
- Guiding plate for chain
- Timing double gear
- Re-assembly
- Re-assemble timing double gear [1], coat
- all the surface of timing chain [1] with

crankcase body.

- Remove limit pin [2] for guiding plate and
- limit pin [3] for tensioning plate by
- magnet and tweezers.
- 
- 

move timing chain [1], guiding plate [2] and tensioning plate [3] for chain.

- oil, the match up and assemble with double
- gear, the align the 2 timing points on
- double gear to that on driving and timing

- gear, then assemble into crankcase.
- 
- 



- Put tensioning plate and guiding plate into crankcase from upper side of chain chamber, then align the hole to corresponding hole on crankcase body.
- Coat the limit pin for both tensioning plate and guiding plate with oil, then insert into corresponding hole.
- Caution: Make sure the limit pin was also inserted into limit hole for tensioning and guiding plate.
- Assemble the parts below:
- Water pump kit
- Cylinder head

## - 6 Clutch and gearshift

### - Maintenance

#### - Summary

- The maintenance for clutch and gearshift device in this chapter needn't remove the engine from frame.
- The oil level and viscosity has influence on separation of clutch. When the clutch failed to separate or the motorcycle is still in low speed when clutch separated, please check the oil level before clutch maintenance.

#### ● Tool(s)



### - Specification for clutch and gearshift device

Unit: mm

- Items	- Standard	- Maintenance limit
- Free play of clutch lever	- 10-20	- —

### - Troubleshooting

- Difficult to hold clutch lever tightly
  - The clutch cable damaged, twisted or too dirty
  - Wrong wiring for clutch cable
  - The thrust mechanism of clutch got damaged
  - Malfunction in bearing of clutch's pushing rod
  - Incorrect installation for operational rod of clutch
- Clutch skidding in acceleration
  - Jamming on clutch's pushing rod
  - Driving friction plate worn out

- Poor performance for clutch spring
- Not any free travel on clutch lever
- Molybdenum disulfide or graphite additive gets into oil
- When clutch separated or failed to separate, the motorcycle is still under low speed
  - Too wide the free travel of clutch lever
  - The friction plate of clutch gets warped
  - Too high the oil level, wrong viscosity or incorrect additive
  - The locking nut on clutch center case gets loosened
  - Thrust mechanism of clutch gets damaged
  - Incorrect installation for clutch's operational rod
  - The inserting groove on clutch outer case and clutch gear worn out
  - Wrong operation for clutch
- Difficult gearshift
  - Incorrect adjustment for clutch cable
  - Wrong operation on clutch
  - Wrong viscosity of oil
  - The gearshift fork gets damaged or bent
  - The shaft of gearshift fork gets bent
  - The claw of gearshift fork gets bent
  - The bolt on five-star shaped plate gets loosened
  - The five-star shaped turning plate gets damaged
  - The guiding groove on gearshift drum gets damaged
  - Five-star shaped turning plate gets worn out or damaged
- Gear jump in transmission system
  - Check plate gets worn out
  - Poor performance even damage on returning spring of check plate
  - The bolt on five-star shaped turning plate gets loosened
  - Five-star shaped turning plate gets damaged
  - Shaft of gearshift fork gets bent
  - Gearshift fork gets bent or damaged
  - The meshing surface or teeth groove gets damaged
- Gearshift plate fails to return
  - The poor elasticity of returning spring of gearshift spindle or gets cracked
  - Gearshift spindle gets bent or damaged

## - Right crankcase cover

- Disassembly/Re-assembly
- 
- The accessories need be removed shall clutch operation arm. supplement by project team.
- Drain off oil in engine.
- Remove bolt [1] and locating plate [2] for clutch cable, then remove clutch cable from

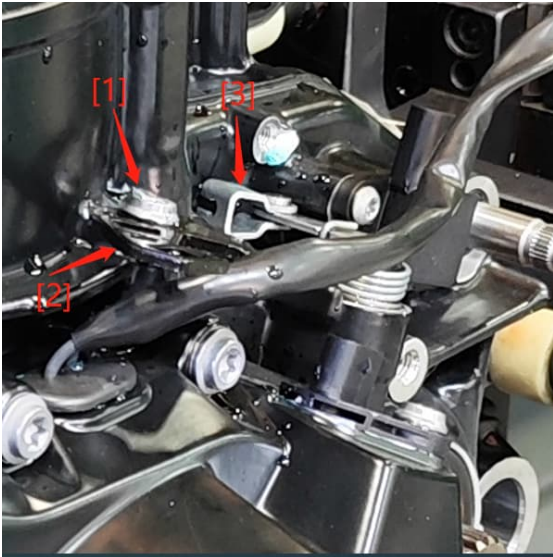

- The accessories need be removed shall supplement by project team.

- Loosen bolt [1] on right crankcase cover
- by 2-3 times in alternative way.
- Caution: The two bolts in position pointed by arrow are with washer, please mark them up.
- Remove the parts below:
- Bolt
- Right crankcase cover kit [2]

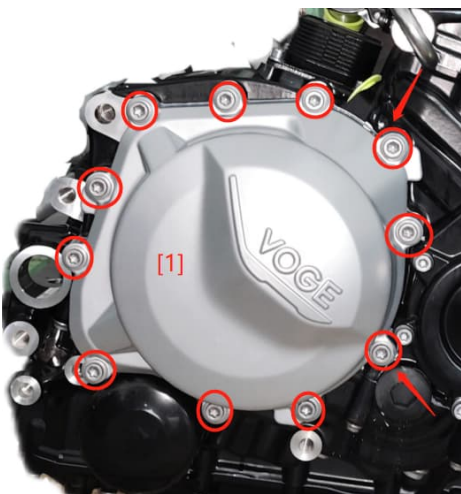

- Clean up residual sealant on contact surface

- between crankcase and its cover without damaging the surface.
- The re-assembly is precisely opposite to disassembly.
- Torque:
  - Bolt for right crankcase cover: 20N·m
- Caution:
  - Coat contact surface of right crankcase cover with sealant as picture shows.
  - Replace the washer for re-assembly for a new one.
- Adjust the free play for clutch lever.
- Fill up crankcase with oil we suggest and check if there is oil leaks.

## Disassembly/Re-assembly

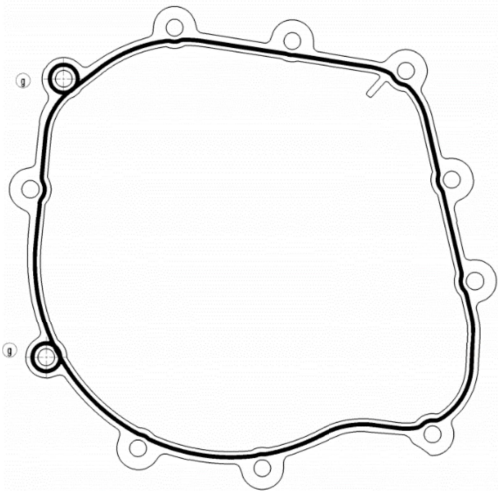

Loosen bolt [1] for pressure bolt of damping rubber sheet for right crankcase, then remove pressure plate [2] and damping rubber sheet [3].

The re-assembly is precisely opposite to disassembly.

Caution:

Loosen

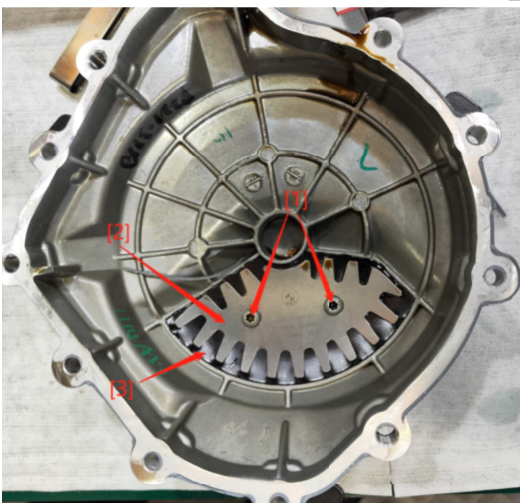

place the bolt for pressure plate for a new one (Coat with sealant).

Reassemble

- The surface of damping sheet with mark face outwards.
- The surface of pressure plate with mark face outwards.
- Torque: 6N·m

## Inspection

- Check if there is scratch, damage, wear-out or distortion on parts below.
- Pressure plate for damping rubber sheet.
- Bolt for pressure plate of damping rubber sheet.

## - Clutch

### Removal

- Remove right crankcase cover.
- Loosen bolt [1] for lift plate in alternative

way by 2-3 times, remove bolt, lift plate [2] and clutch spring [3], clutch spring base and pressure plate [5] for clutch.

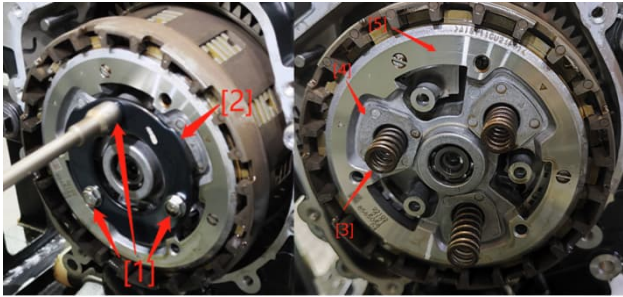

Disassemble locking side of locking nut on central case of clutch. The remove driving and driven friction plate and disc spring for clutch.

*Caution: Please don't damage threaded part of main shaft.*

Remove pushing rod [1] for clutch and operation arm [2] for clutch.

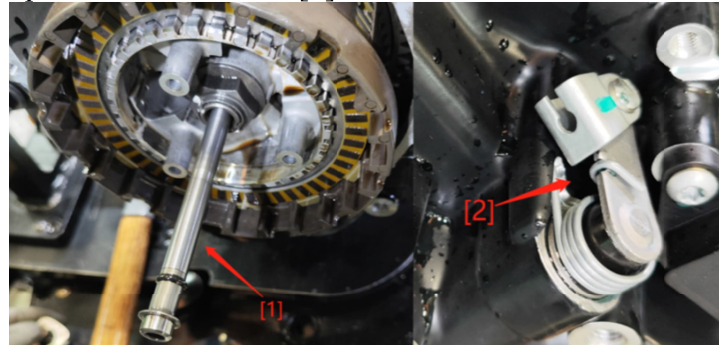

Fix central case for clutch by tools for it only, meanwhile loosening locking nut [1].

Tool:

Turning stop tool for central case [2]

Remove locking nut.

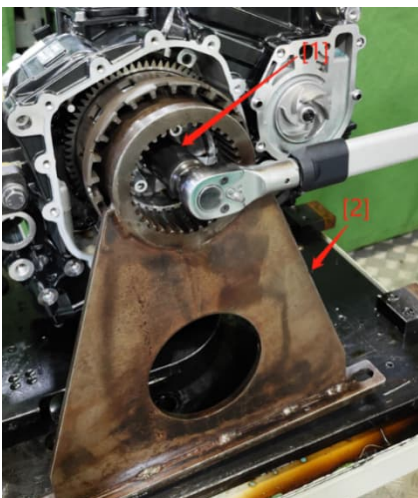

Remove central case [1] and washer [2] for clutch.

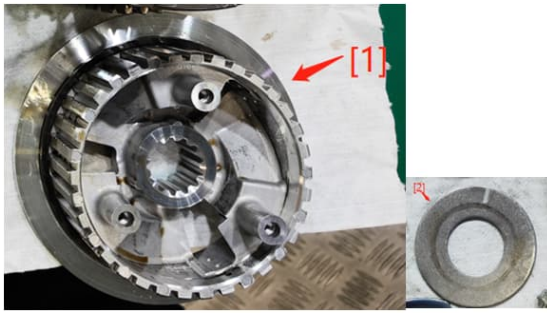

- 
- 
- 
- 
- 
- 
- 
- 
- 
- 

Remove outer case [1], needle bearing[2], bearing collar[3], washer

[4], and collar [5] clutch.

- 
- 

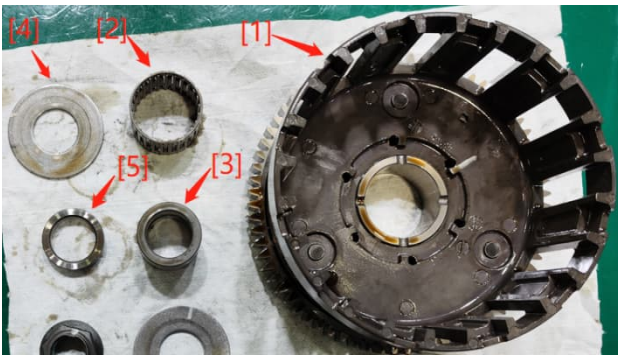

### Inspection

- Check and confirm if there is scratch, damage, wear-out or distortion on parts below, in case it is, please replace.
- Pushing rod of clutch
- Operation arm for clutch
- Lift plate for clutch
- Spring
- Central case of clutch
- Washer
- Disc spring
- Driving and driven friction plate
- Outer case of clutch/Primary driven gear
- Needle bearing/Collar
- Collar for clutch
- Main shaft
- Caution:
  - Replace clutch spring as a kit.
  - Replace driving and driven friction plate as a kit.

- 
- 
-

## Re-assembly

- Re-assemble collar and washer for clutch to
- Coat needle bearing and its inner and outer hole for outer case of clutch, surface of primary driving and driven gear with clean engine oil.
- Re-assemble outer case of clutch together with needle bearing and its collar.

main shaft

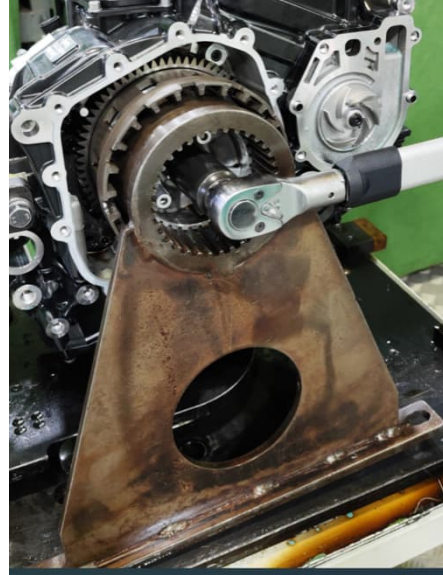

- Caution:
  - Make sure correct meshing-up between driving and driven primary gear.
  - Re-assemble washer and central case of clutch.
  - Re-assemble locking nut, then fasten it by turning stop for central case of clutch only.
  - Torque: 190N·m
  - Caution, when the first time fastened to 190N·m, loosen it anticlockwise by 45°, then fasten to 190N·m once again. When fastened, get opening of clutch nut distorted by chisel and get it sunk, which closely stick to gap on main shaft, please don't damage threaded part of main shaft.

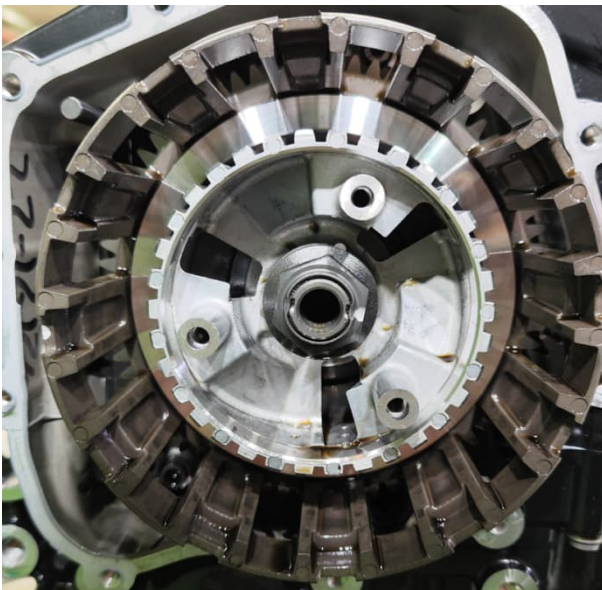

- 
- 
- Re-assemble disc spring into central case of clutch and pay attention to its direction
- Re-assemble pushing rod and operation arm for clutch.

- 
- 
- From driving friction plate [1], re-assemble driving plate and driven plate [2] in turn.
- Re-assemble driving, driven plate and pressure plate onto central case of clutch, then assemble spring base onto pressure plate, then align mark“△” on pressure plate and spring base

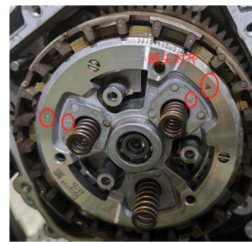
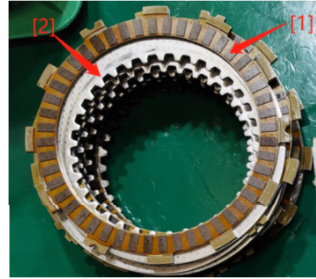

assemble lift plate and its bolt. Please get the side with mark “OUTSIDE” on lift plate face outwards.

- Fasten bolt of lift plate alternatively by 2-3 times to given torque. Torque: 10N•m

- Re-assemble spring to its base, then

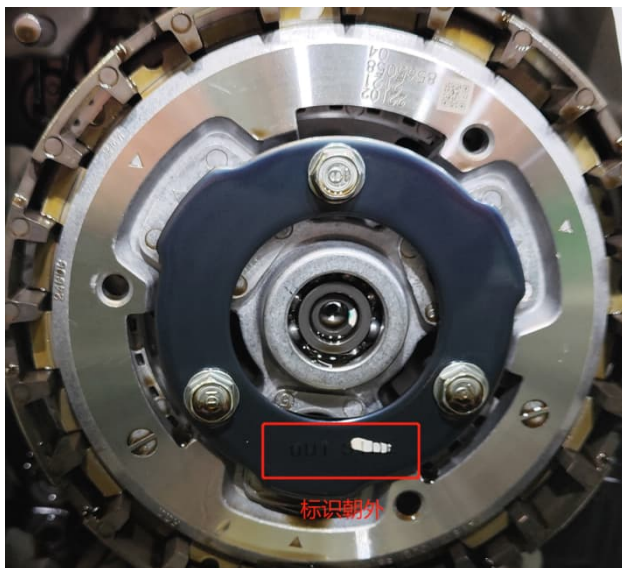

Re-assemble right crankcase cover.

## - Gearshift device

- Disassembly
- Remove the parts below:
- Right crankcase cover
- Clutch
- 
- Remove pin shaft [1], check plate kit
- 

- [2], stoppingtwist spring[3], stopping
- twist spring base [4] and washer [5].
- Caution: Mark up wahsers, please don't
- get confused to that on gearshift arm.
- 
- 

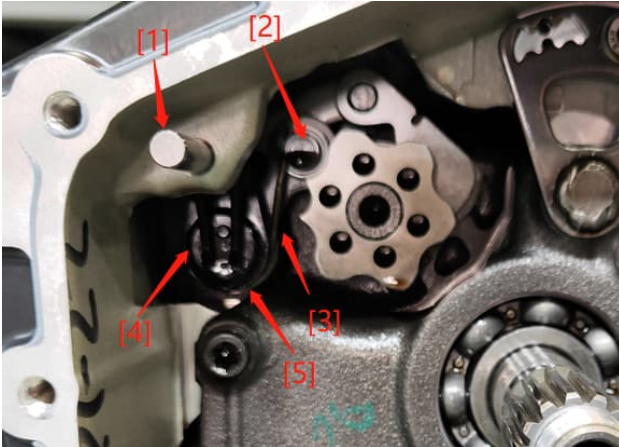

When lift gearshift ratchet up, please pull out gearshift arm kit [1] from crankcase.

- Caution: Please mark up re-assembling sequence for small parts on gearshift arm kit for a correct re-assembly.
- 

### - Inspection

- Check if there is damage, wear-out or distortion on parts below, replace if it is necessary.
- Five-star turning plate
- Check plate kit
- Stop twisting spring
- Stoping spring base
- 
- 
- 

### - Gearshift arm

- Check if there is fatigue or damage on reutnring spring [1] for gearshift and
- turning spring [2] for gearshift arm, replace if it is necessary.
- Check if there is wear-out or
- Distortion on gearshift spindle.

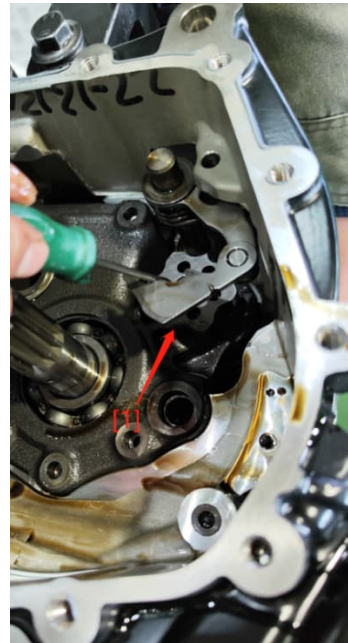

- Check if there is wear-out, damage or distortion on gearshift ratchet.
- Replace gearshift arm kit as a complete set if it is necessary.
- 
-

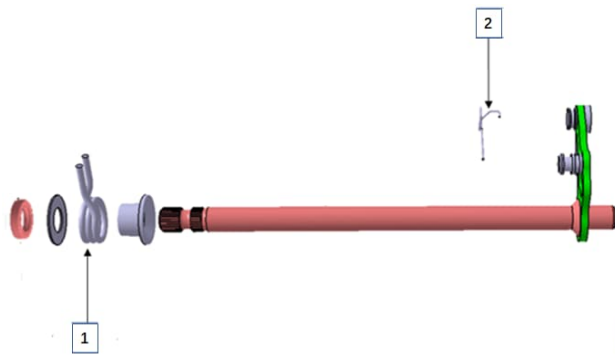

## Re-assembly

- Re-assemble gearshift arm kit [1] into gear box cover, the gearshift ratchet is behind five-star turning plate.

- Re-assemble pin shaft [1], check plate kit [2], stopping twist spring [3], stopping twist spring base [4] and the washer [5].

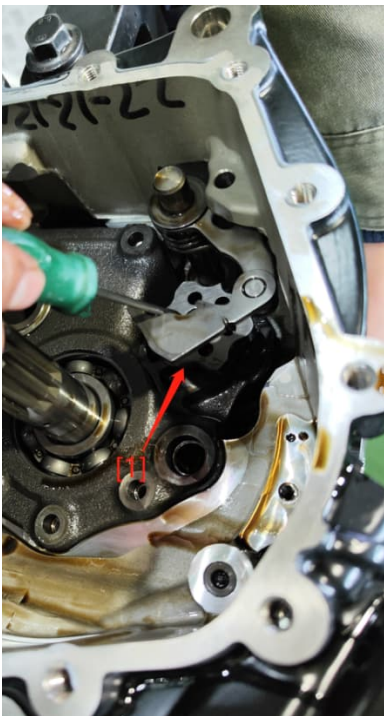

- Re-assemble clutch,
- Re-assemble right crankcase cover.

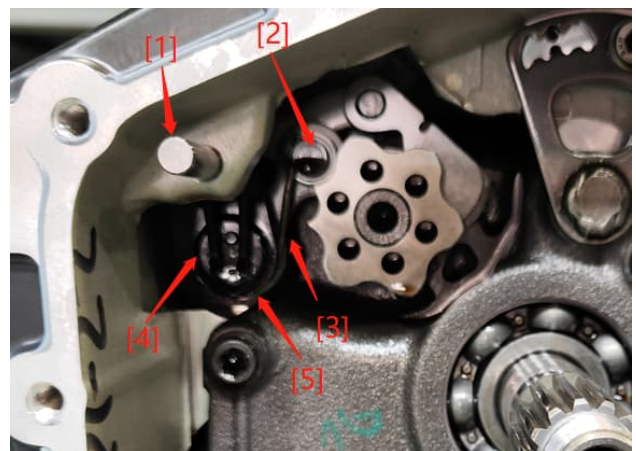

- 
- 
- 
- 
- 
- 
- 
- 

- 
- 
- 
- 
- 
- 

- Disassembly/Re-assembly for gearshift pedal

- Supplement by project team

## - 7 Magneto and starting clutch

### - Summary

- The maintenance for stator and rotor of magneto needn't remove the engine from frame.
- Check about the charging coil of alternative power generator.
- Check about the trigger.
- Maintenance about starting motor.

### - Specification for magneto and starting clutch

- Unit: mm

- Items	- Standard	- Limit
- External diameter for shaft jacket of starting plate shaped gear	- 51.705-51.718	- 51.685
- Internal diameter for outer case of starting clutch	- 68.364-68.390	- 68.400

-

-

### Tool (s)

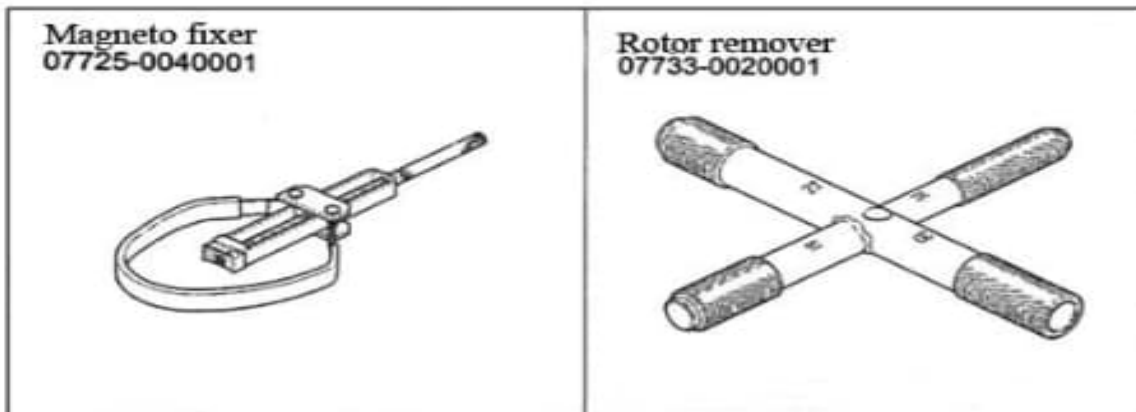

-

### - Troubleshooting

- Starting motor is run, while engine failed starting
- Malfunction in starting clutch
- Malfunction in double gear or its shaft of starting motor
- Smaller gear of starting motor in malfunction or worn out
- Malfunction in driving gear of starter

-

### - Left crankcase cover

- Disassembly/Re-assembly

- Caution:
- When removing left crankcase cover, lay a clean oil tray under engine to prevent oil flowing out. When re-assembled, fill up with appointed oil to given amount.
- Keep motorcycle upright on horizontal ground.
- Remove parts below:
- The accessroies need be removed shall suppelement by project team.
- 
- 
- 

- Loosen bolt [1] on left crankcase in diagonal sequence by 2-3 steps.
- Remove parts below:
- Bolt
- Left crankcase cover [2]
- Caution:
- The left crankcase cover (Stator) bears magnetive absorption from rotor, be carefuel when removing it.
- Clean up residual sealant on left crankcase and all the contact surfaces.
- The re-assembly is previesly opposite to disassembly.
- Before re-assembling magneto cover, coat its contact surface with sealant of Dow Corning.
- Torque:
- Bolt on left crankcase: 20N·m

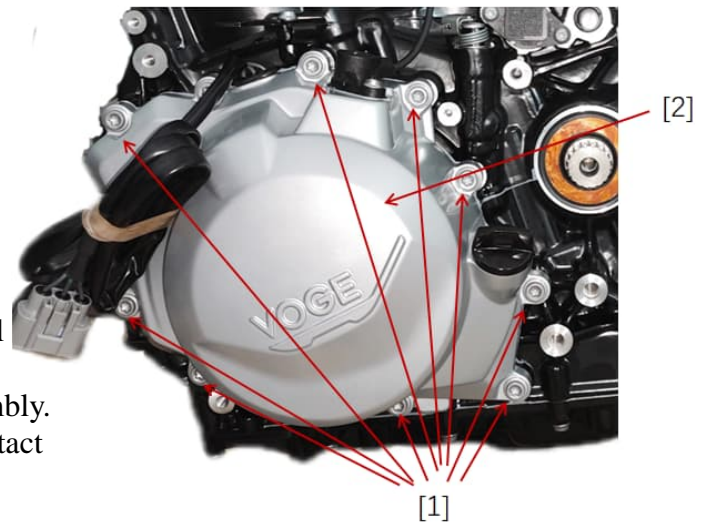



- Coat new bolt for stator with Loctite in advance.
- Torque: 10N·m
- Replace bolt of wire clip for a new one with Loctite coating on it. Torque: 6N·m
- Bolt for crankshaft position sensor. Torque: 10N·m

## - Stator of magneto

- Removal
- Remove left crankcase cover.
- Remove the shaft [1] of double gear and the gear [2].

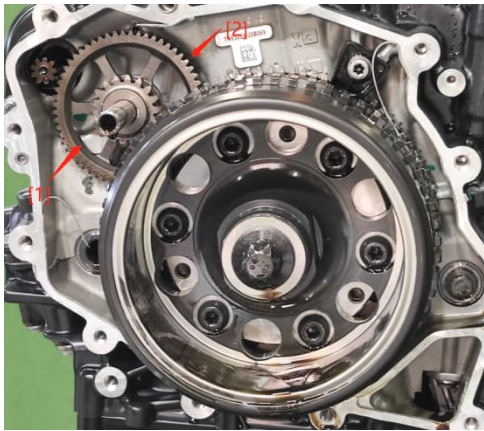

Fix

- 
- 
- rotor of magneto by its turning stop tool [1], then loosen bolt [2] for magneto.
- Remove bolt for rotor and the washer.
- 

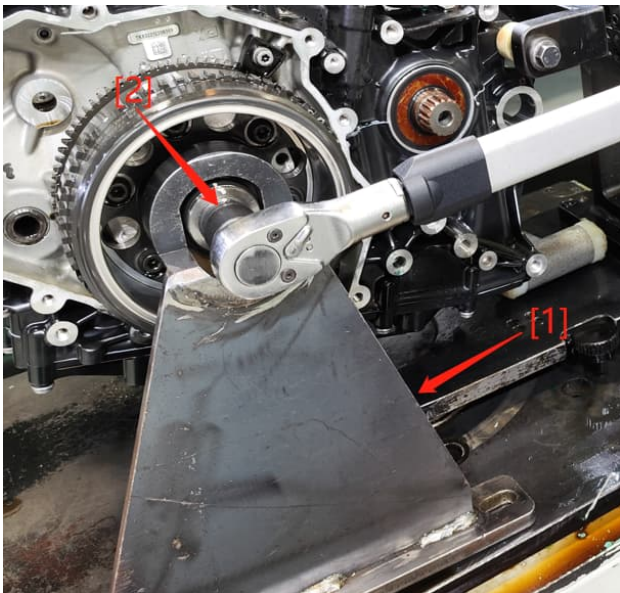

- 
- 
- Remove rotor [1] by external hex. bolt of M22×15 [2].
- 
-

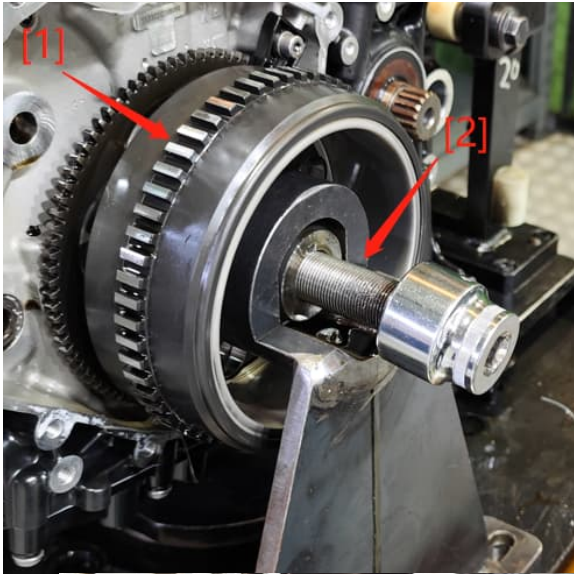

- Loosen bolt [1] for limit piece of plate
- shaped gear. Then remove the limit piece
- [2].
- Remove semi-round key [3] by knocking of
- rubber hammer.
- Please don't damage semi-round key and
- crankshaft.
- Remove plate shaped gear kit [4].
- 
- 

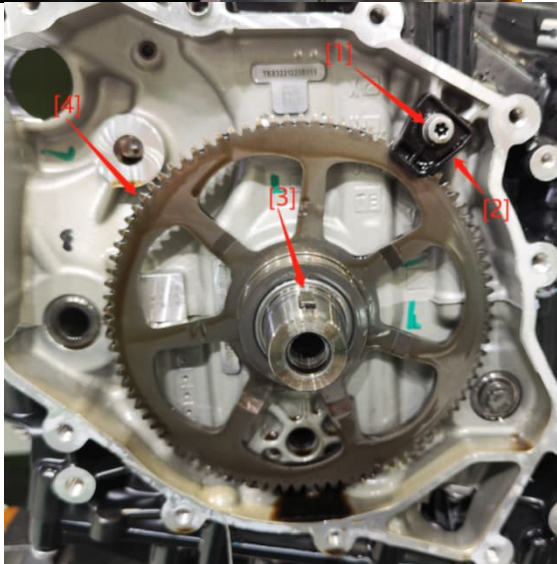

## Inspection

- Check if there is scratch, damage, wear-out or distortion on parts below,
- Please replace if it is necessary.
- Double gear shaft
- Double gear
- Semi-round key
- Plate shaped gear and needle bearings.

## Re-assembly

- Coat contact area [1] of needle
- Bearing with engine oil. Re-assemble
- plate shaped gear [2].
- Assemble limit piece [3] for plate
- gear then fasten the bolt [4] for limit
- piece.
- Caution: The newly replaced bolt needs
- coat with Loctite. Torque: 10N·m

- Coat contact surface of plate gear and
- rotor with engine oil.
- 
- 
- 
- 
-

-  
-  
-  
-  
-

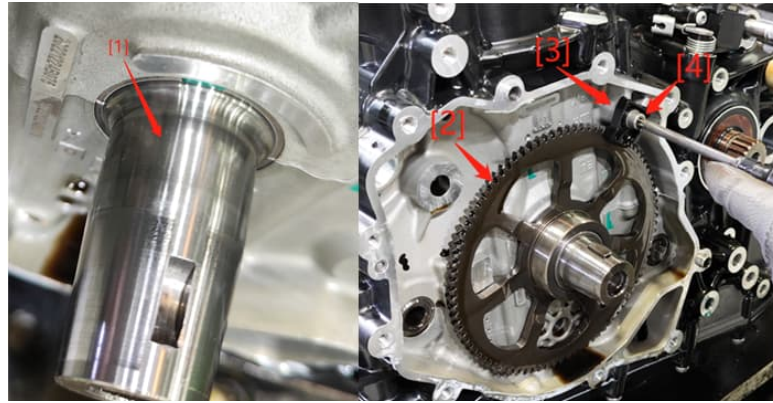

- Re-assemble semi-round key [1].
- Please don't leave damage on semi-round key and crankshaft.

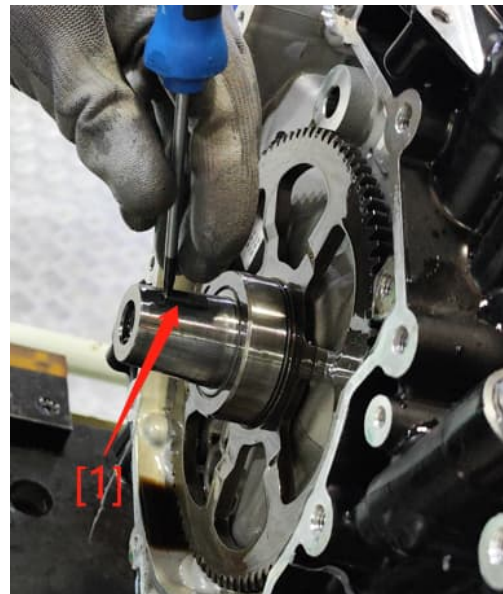

-  
-  
-  
-  
-

- Totally clean up oil on taper surface of crankshaft and inner hole of rotor.
- Re-assemble rotor [1] for magneto.

-  
-  
-  
-  
-

- Caution: Please align semi-round key on crankshaft to its groove on rotor.

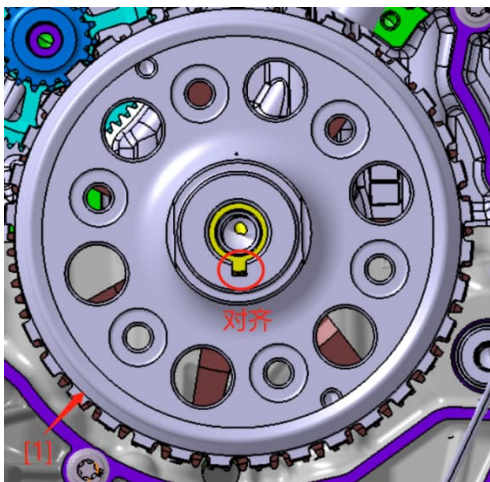

- assemble washer and bolt [2] for rotor.
- Fix rotor [1] by stop turning tool, then fasten bolt to given torque.
- Torque: 150N·m

- Re-

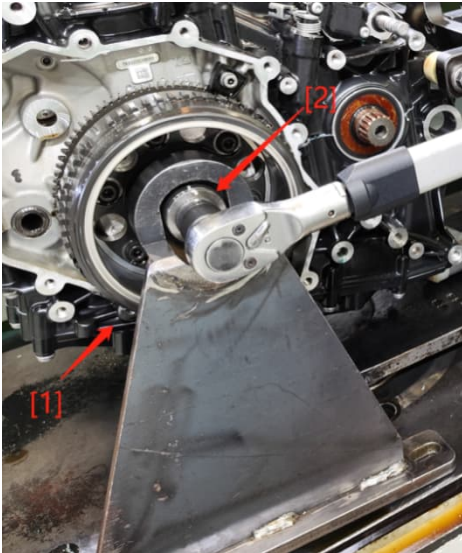

- 
- Coat outer surface of double gear shaft with engine oil.

- Re-assemble double gear [1] and its shaft [2].
- Re-assemble left crankcase cover.

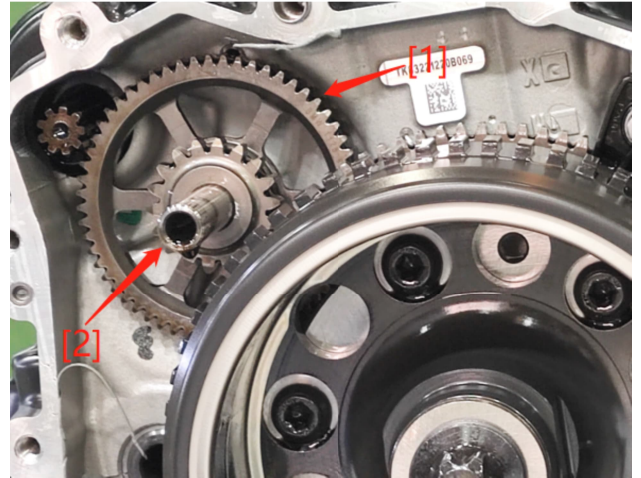

-

## - Starting clutch

- Inspection for operation of starting clutch
- Remove left crankcase cover without removing rotor.
- Check operative performance for starting clutch by turning plate shaped gear [1].
- Check smooth turning of plate shaped gear of anticlockwise.

-

-

-

-

### Removal

- Remove rotor for magneto.
- Loosen bolt [1] for starting clutch, then remove starting clutch kit.
- Caution: Protect inner cover of rotor, the

- rotor is strongly magnetic, please avoid collision of bolt or gun tip on inner cover.

-

-



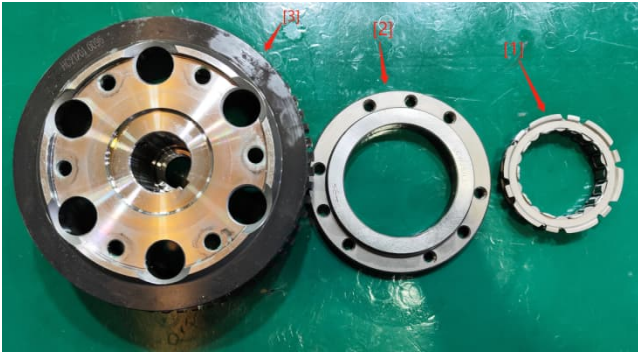

- Coat newly replaced bolt with Loctite, then fasten the bolt to given torque.
- Torque: 35N·m

- Check smooth turning of plate shaped gear
- of anticlockwise, also check if it is
- without clockwise turning.

- Re-assemble rotor of magneto.
- Check operative performance of
- Starting clutch by turning plate shaped
- gear [1].

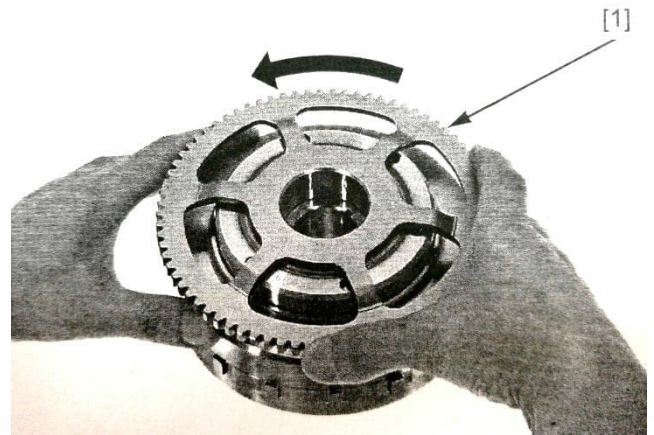

# - 8 .Case body and - transmission system

## ■ Maintenance information

### - Summary

- Break up the crankcase for the maintenance below:
  1. Crankshaft
  2. Balancing shaft
  3. Piston and connective rod
- Remove the parts below before breaking up crankcase: :
  1. Engine
  2. Gearshift system and gear box cover
  3. Left crankcase cover
  4. Magneto kit and starting motor kit
  5. Right crankcase cover and clutch kit
  6. Cylinder head kit
  7. Tensioner
  8. Tensioning and guiding plate
  9. Oil bottom case
  10. Primary oil filter
  11. Oil pump
  12. Oil collective tray
  13. Secondary oil filter
  14. Water pump kit
  15. Water tube
  16. Gear indicator switch set
  17. View hole cap
- Please don't damage the combination surface of crankcase when repairing.
- Wash and clean the oil passage before re-assembling the crankcase.
- Before combining the case, coat the combination surface with sealant for end surface evenly, the surplus sealant must be clean up.
- Mark up the pad on bigger end of connecting rod and that on main shaft with suitable color, select the shaft pad according to the requirement in its <Selection Table>, check the oil gap when shaft pads re-assembled, wrong oil gap may heavily damage the engine.

- Tool:

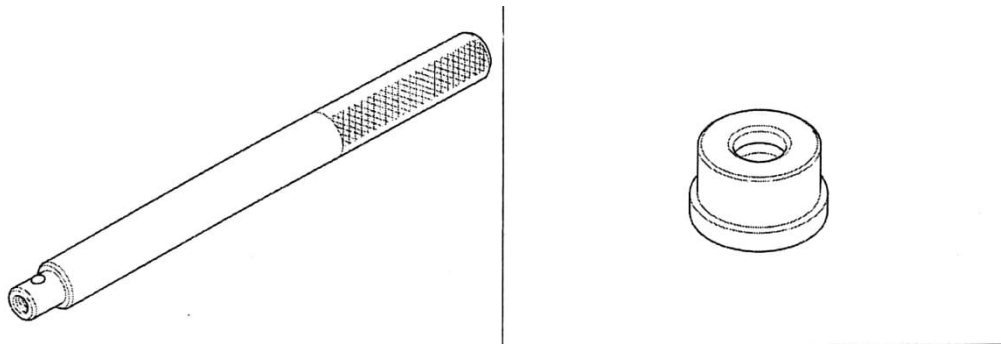

- Specification for crankcase body and transmission system

- Unit: mm

Items		Standard	Maintenance limit	
Transmission device	Inner hole diameter for gear	Main shaft gear 6th and 5th	30.000-30.013	30.03
		Counter shaft gear 1th, 2th, 3th and 4th	34.000-34.016	34.03
	Width for needle bearing	Main shaft gear 6th and 5th	12.45-12.80	12.4
		Counter shaft gear 1th, 2th, 3th and 4th	12.45-12.80	12.4
	Shaft diameter for main shaft	Match up with needle bearing of main shaft gear 6th and 5th	25.982-25.993	25.97
		Match up with needle bearing for Counter shaft gear 1th, 2th, 3th and 4th	29.980-27.993	29.96
Turning fork and its shaft	Shaft diameter for turning fork shaft		11.967-11.994	11.96
	Inner diameter for turning fork		12.016-12.043	12.06
	Tip thickness for turning fork		4.85-4.95	4.8
	Diameter for	Left and right	46.55-46.85	46.9

	turning fork opening	- turning fork		
		- Middle turning fork	- 34.05-34.35	- 34.4
- Opening on gear	- Width for opening	- Main shaft gear 3th-4th	- 5.05-5.13	- 5.2
		- Counter shaft gear 5th and 6th	- 5.05-5.13	- 5.2
	- Diameter	- Main shaft gear 3th-4th	- 33.85-33.95	- 33.7
	- Diameter	- Counter shaft gear 5th and 6th	- 45.85-45.95	- 45.7

-  
-  
-

## - Troubleshooting

- Difficult gearshift
  - Wrong operation on clutch
  - Wrong viscosity of oil
  - Gearshift fork got distorted
  - Gearshift's shaft got distorted
  - Ratchet of gearshift's fork got distorted
  - Guiding groove on gearshift drum got damaged
  - Gearshift arm got distorted
- Gear jump in transmission system
  - Gear got worn out
  - Guiding groove of gearshift drum got worn out
  - Gearshift fork's shaft got distorted
  - Gearshift drum got damaged
  - Twist spring of locating plate got damaged
  - Gearshift fork got worn out or distorted
  - Gearshift arm got damaged
- Noisy engine
  - Transmission gear got worn out or damaged
  - Transmission bearing got worn out or damaged

-  
-

## - Crankcase body

- Disassembly
  - off,
  - then remove the locating plate [2].
- Loosen bolt [1] for locating plate of centre-
  - Loosen bolt [3] of gear box cover, remove





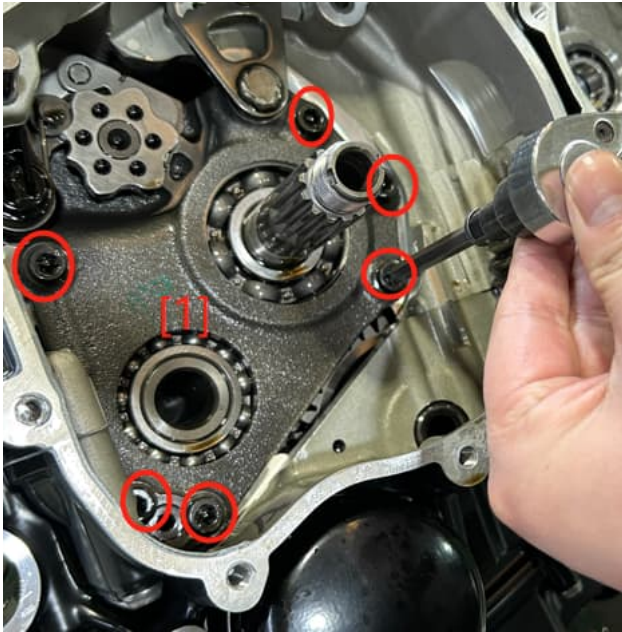

- Wash contact surface between upper and lower crankcase, please don't damage the

- Coat shaft pad [1] of journal of crankshaft and journal [2] of balancing shaft with oil.

- Assemble lower crankcase body [1] onto the upper one.
- Replace all the re-assembling washer of case combination bolt for a new one.
- Re-assemble case combination bolt of M10

contact surface.

- Check if the oil passage of case body was blocked up, please wash the oil passage if it is necessary.
- As picture on the right, coat end surface sealant on contact surface of lower case body.
- Caution:
  - Too much end surface sealant coated is not allowed.
  - Please don't coat oil passage and view-hole cap with end surface sealant.

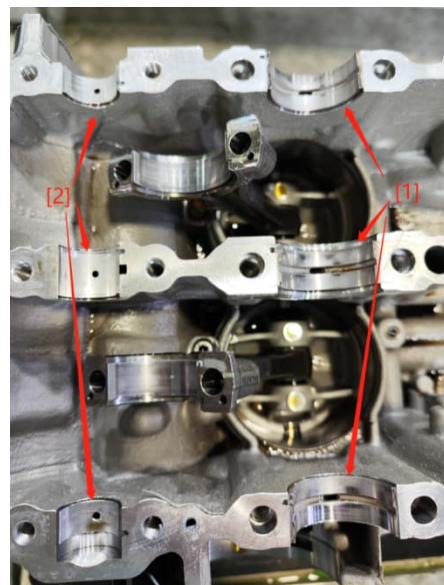
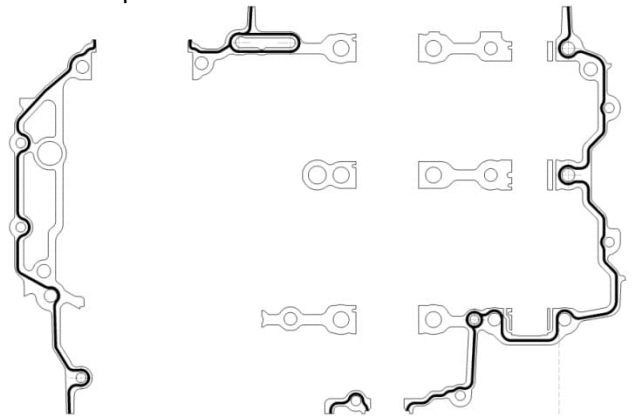

- [2] for a new one.
- Caution:
  - Please don't use case combination bolt of M10 which has already been used.
  - Confirm the firm assembly for upper and lower case body.
  - Fasten bolt M10 to given torque according

to

- sequence as picture shows by 2-3 times.
- Turn the case combination bolt of M10 by 80° for further strengthening.

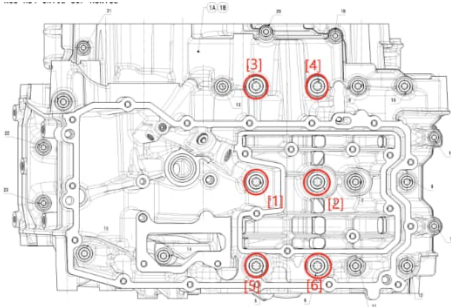

- Assemble new case combination bolt [1] of M8.
- Caution:
- Please don't use the case combination bolt of M8 which has already been used.
- Fasten bolt of M8 to given torque by sequence
- as picture shows by 2-3 times.
- Turn bolt of M8 by 80° for further strengthening.
- Torque: 5N.m+80°

- Assemble combination bolt [1] of M6.
- Fasten bolt M6 to given torque by sequence as picture shows by 2-3 times.
- Torque: 10N.m

- The re-assembly is precisely opposite to disassembly.

- Torque: 10N.m+80°

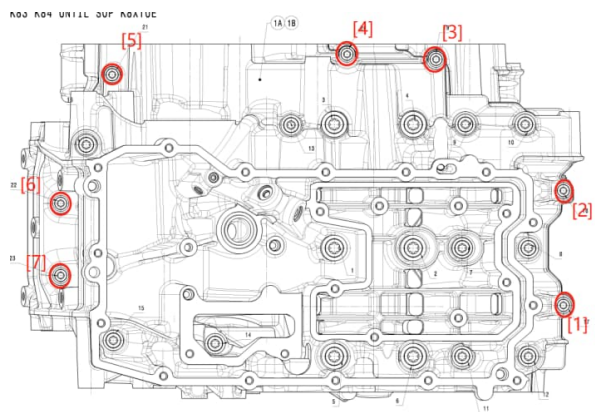
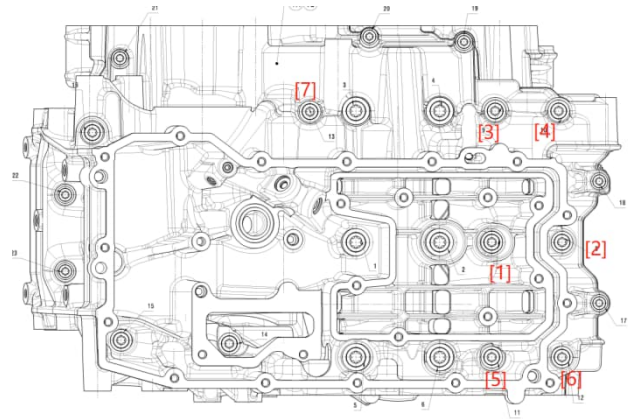

## - Transmission

- Disassembly
  - Disassemble upper and lower crankcase body.
  - Remove gear box cover [1] together with main
  - and countershaft, gearshift drum, turning fork
  - and its shaft from crankcase body.

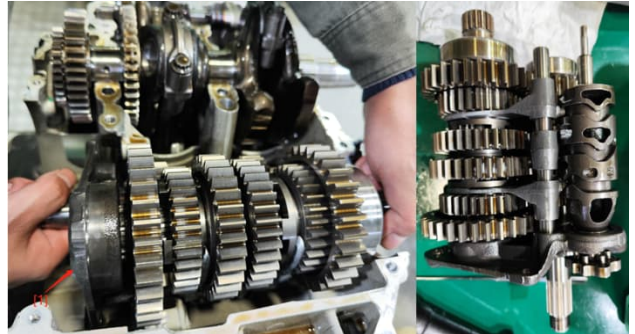

- Remove main shaft [1], counter shaft [2], turning fork shaft [3] and the fork from gear box cover.
- Caution: The five star turning plate and gearshift drum are press-fitted on gear box cover in interference way, whose forced disassembly are not allowed.



- Caution:
  - The bearings on both ends of main shaft and counter shaft are press-fitted in interference way, whose forced disassembly is not allowed.
- Inspection
  - Check if there is scratch, damage, wear-out or distortion on parts below, replace if it is necessary.
  - Transmission gear
  - Transmission shaft jacket
  - Transmission bearing
  - Gearshift drum/Gear shift drum bearing
  - Gearshift turning fork
  - Gearshift turning fork shaft
  - Measure size for each part, calculate matching clearance according to standard, in case it is passed standard, please replace the parts.

- Re-assembly
- Wash all the parts by solvent then get it totally dried.
- Coat the surface of gear teeth, turning surface and place of bearing with oil.
- Re-assemble main shaft, counter shaft, turning fork and its shaft onto gear box cover to their original status.
- Caution: The gearshift fork is with mark below:



- “L”[1]: Left turning fork
- “C”[2]: Middle turning fork
- “R”[3]: Right turning fork 右拨叉
- Coat guiding area of turning fork and its guiding pin’s position with oil.

Re-assemble crankcase body.

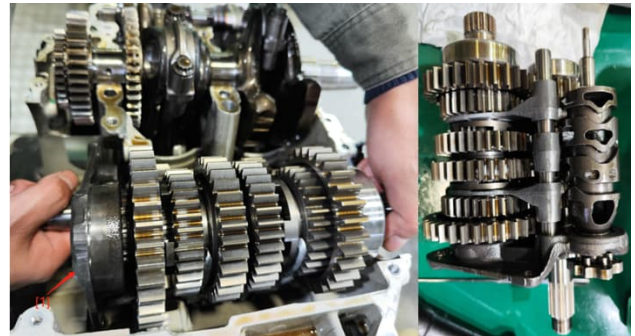

Assemble gear box cover kit [1] into crankcase body.

## - 9Crankshaft, piston, cylinder and

# balancing shaft

## - Maintenance information

### - Summary

- When maintaining the crankshaft, balancing shaft, cylinder body, piston/connecting rod and nozzle, the crankcase must break up. How to break up the crankcase refer to its corresponding chapter.
- Mark up the bigger end of connecting rod, cover of the rod and crankshaft pads and well put aside to make sure the correct re-assembly.
- The crankshaft's pin and pad of main shaft's journal gets matched according to their color, select the crankshaft's pad according to its color. When the new pad selected, confirm the clearance of oil film by plastic feeler gauge, the wrong clearance of oil film may heavily damage the engine.

### - Tool(s):

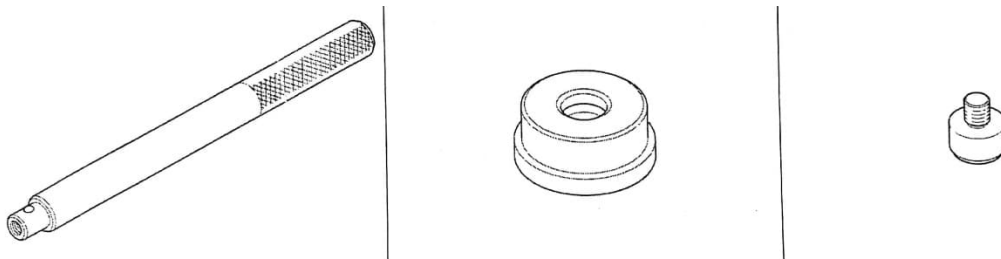

## - Specification for crankshaft, piston, cylinder body and balancing shaft

- Unit: mm

	- Items	- Standard	- Limit
- Crankshaft	- Clearance in bigger end of connecting rod	- 0.10-0.25	- 0.27
	- Clearance between pad on bigger end of connective rod and crankshaft	- 0.034-0.059	- 0.065
	- Clearance between journal of crankshaft and pad	- 0.030-0.058	- 0.065
	- 跳动	- —	- 0.035
- Cylinder	- Cylinder bore	- 85.994-86.006	- 86.05
	- Roundness loss	- —	- 0.10
	- Taper	- —	- 0.10
	- Cylindricity	- —	- 0.10
- Piston,	- Diameter for base circle of	- 85.956-	- 85.90

piston pin and piston ring	piston		85.974	
	– Diameter of pin's hole		– 19.008- 19.013	– 19.02
	– Diameter for piston pin		– 18.992- 19.000	– 18.98
	– Clearance between piston and piston pin		– 0.008-0.021	– 0.04
	– Closing clearance for piston ring	– 1 <sup>st</sup> ring	– 0.15-0.30	– 0.4
		– 2 <sup>nd</sup> ring	– 0.20-0.40	– 0.5
		– Oil ring	– 0.20-0.70	– 1.0
	– Piston ring and ring groove clearance	– Clearance between 1 <sup>st</sup> ring and groove	– 0.030-0.070	– 0.10
		– Clearance between 2 <sup>nd</sup> ring and groove	– 0.020-0.060	– 0.08
	– Cylinder matching clearance			– 0.020-0.050
– Internal diameter of smaller end of connecting rod			– 19.017- 19.027	– 19.035
– Matching clearance between connecting rod and crankshaft pin			– 0.017-0.035	– 0.05

## – Troubleshooting

- Too low the cylinder pressure, difficult starting or poor performance under low speed
  - Air leakage of cylinder head's gasket
  - Wear-out, jamming or damage on piston ring
  - Cylinder head/Piston worn out or damaged
- Too high the pressure in cylinder, cylinder body overheat or cylinder knocking
  - Too much the carbon buildup on the top of piston
- Too much waste gas
  - Cylinder body, piston or its ring got worn out
  - Wrong assembly for piston ring
  - Scratch on piston or cylinder wall
- Engine noisy
  - Piston pin or the hole for pin got worn out
  - Smaller end of connecting rod got worn out

- Cylinder body, piston or its ring got worn out
- Crankshaft pin's pad got worn out
- Engine vibration
- Too strong the runout of crankshaft

## - Crankshaft

- Inspection for side clearance
- Break up upper and lower crankcase body.
- Measure side clearance of connective rod.
- Maintenance limit:0.27mm。
- In case the clearance passed maintenance

- limit, please replace connective rod.
- Confirm side clearance once again, in case still
- passed limit, please replace the crankshaft.

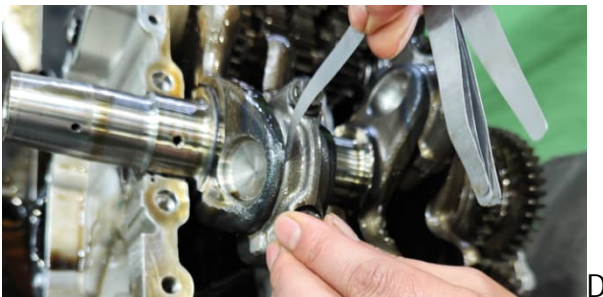

isassembly

- Caution:
- *Please don't change the position of crankshaft pad, the pad must be at its original place, otherwise the oil film clearance will be wrong which badly damage engine.*
- Break up upper and lower crankcase body.
- Remove front balancing shaft.
- Mark up shaft and connective rod cover before removal for correct re-assembly.
- Remove bolt [1] and its cover [2] of connective bolt cover. Please don't damage crankshaft, journal of main shaft and shaft pad.
- In case the connective rod cover is difficult to be removed, please slightly knock side of the cover by rubber hammer, then remove crankshaft [3].

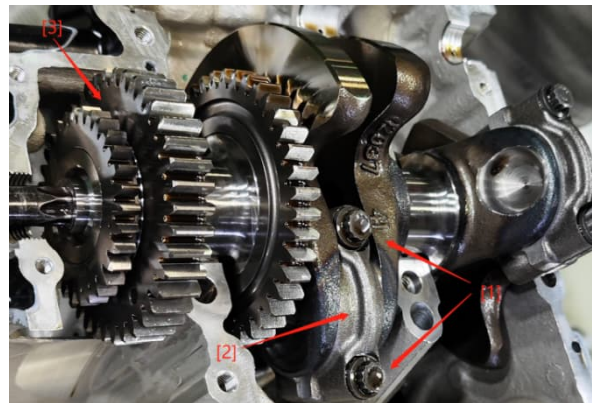

- Caution:
- Before removing crankshaft, push piston to lower stopping point to prevent damage on crankshaft.
- Remove shaft pad [1] of journal of main shaft from upper and lower crankcase body.
- Remove shaft pad [2] of crankshaft from bigger end of connective rod and its cover.
- Caution:
- Please don't change the position of crankshaft pad, the pad must be at its original place, otherwise the oil film clearance will be wrong which badly damage engine.

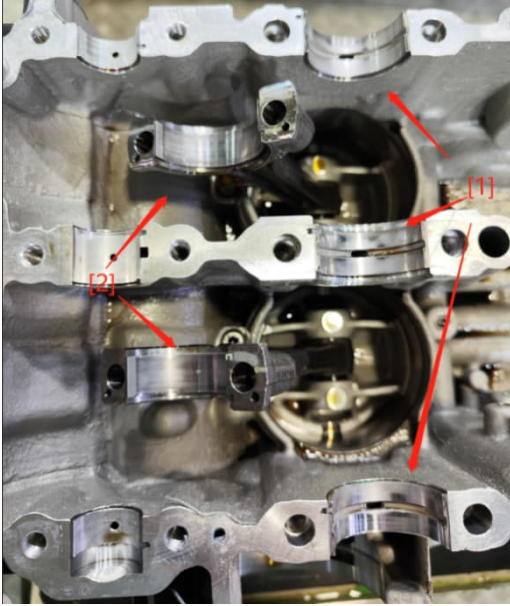

- Inspection
- Hold journal on both ends of crankshaft.
- Lay a micrometer above middle journal of main shaft, please bypass the oil groove and oil hole when laying it.
- Turn the crankshaft by 2 rounds (720°), then



Re-assembly

- Assemble shaft pad [1] of mainshaft and pad [2] of connective rod at their original place.
- Coat shaft pad of journal of main shaft and inner surface of bigger end of shaft pad for connective rod in upper crankcase with oil.
- 
- 
- 
- Slightly assemble crankshaft kit onto crankcase body (Please don't damage crankshaft, journal of main shaft and the

- read its runout.
- Maintenance limit: 0.035mm
- Check balance shaft active teeth [1], primary active teeth [2] and timing active teeth [3] for abnormal wear or damage.
- 
- Caution:
- Please don't change the position of crankshaft pad, the pad must be at its original place, otherwise the oil film clearance will be wrong which badly damage engine.

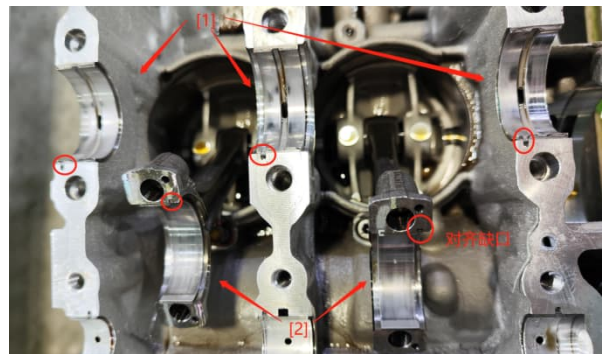

- 
- 
- Align the end of piston skirt to edge of cylinder body.
- 
- 
- shaft pad), make sure the timing indicating point at installation direction of front balancing shaft.

- Coat journal of crankshaft with oil.

-  
-  
-



-  
-  
-



- Put bigger end [1] of connective rod into crankshaft, avoid collision on shaft pad, then clean up contact surface between bigger end of connective rod and its cover, then blow it up by compressed air.

- Confirm the correct matching-up between cover and bigger end of connective rod.

-  
-  
-

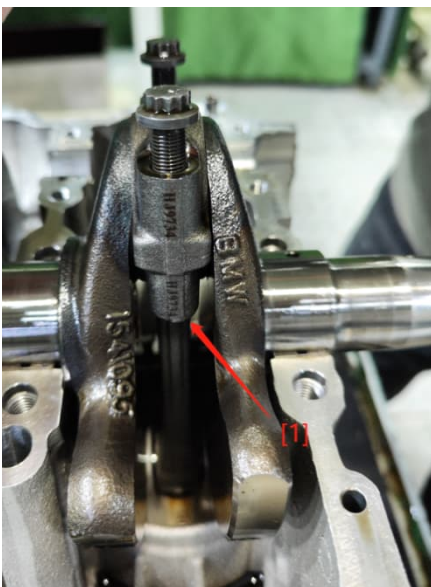

-  
-

- Coat contact place between connective rod

cover and bolt flange, and threaded part of bolt for cover with oil. Pre-fasten the bolt of connective rod cover by 3-4 thread. Make sure the contact between connective rod and its cover.

- Caution:

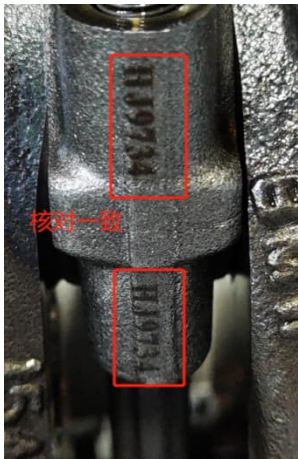

- 
- 
- Re-assemble bolt [1] for connective rod cover, then alternatively turn to given torque
- by 2-3 times.

- *Make sure every part is re-assemble to its original place according to marking-up when it is removed.*

- 
- 
- Turn the bolt of connective rod cover by 100° for further strengthening.
- Torque: 20N·m
- Re-assemble lower crankcase body.

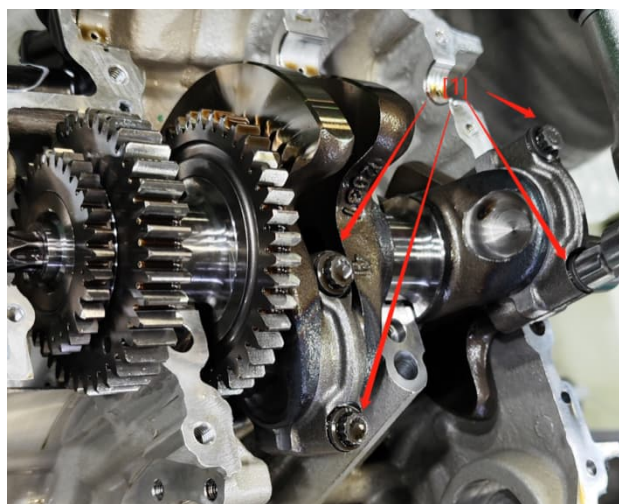

## - Shaft pad of journal for main shaft

- Caution:  
 - *Please don't change the position of shaft pad. The shaft pad must be assembled in its initial position, otherwise the oil film clearance*

- Inspection for shaft pad
- Remove crankshaft.
- Check if there is wear-out or spalling of shaft pad [1] for journal if main shaft.
- Check if there is damage on protrusion [2] of shaft pad.
- In case there is damage on shaft pad for journal
- of main shaft, please choose the correct one for
- replacement.

- *will be wrong, which lead to engine damage.*



- Inspection for oil clearance
- Remove crankshaft.
- Wipe up all the oil on shaft oad and journal of main shaft.
- Re-assemble main shaft into upper crankcase.

- Put a plastic gap gauge [1] on each journal of main shaft bypassing oil hole. (During the inspection of oil clearance, please don't turn the crankshaft).

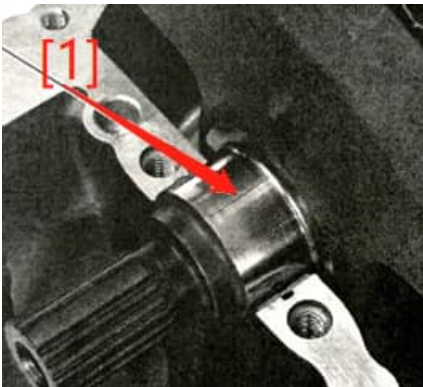

- Re-assemble lower crankcase [1] onto upper crankcase.
- Wash case combination bolt of M10, M8, M6 by cleanser (Repeatedly use), then totally dry it up by blowing.
- Re-assemble case combination bolt.
- Make sure the firm assembly between upper and lower crankcase.
- According to sequence of instruction above, alternatively fasten case combination

bolt to given torque and angle by 2-3 times.

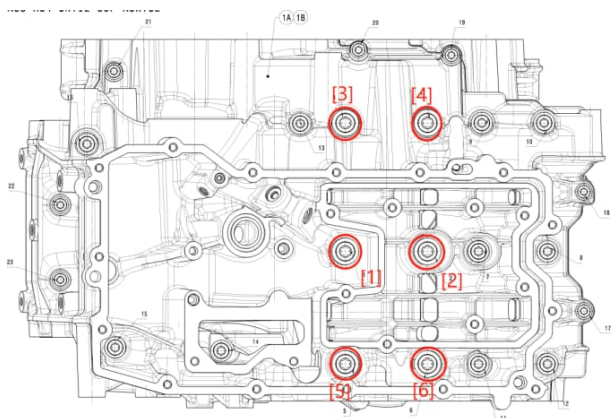

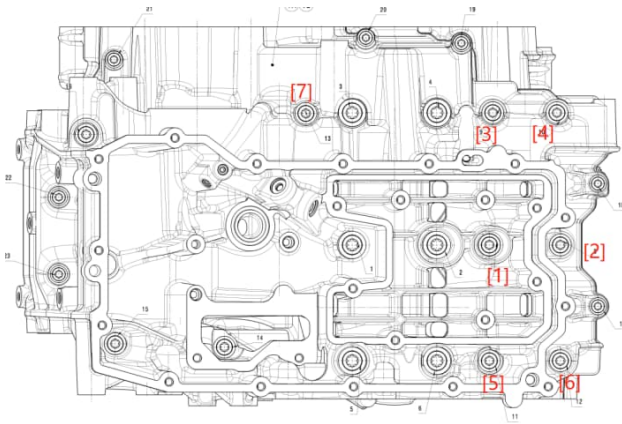

Remove case combination bolt and lower crankcase.

- Measure the widest squeezed width on journal of main shaft by plastic gap gauge to confirm oil clearance.
- Maintenance limit: 0.065 mm

- Shaft pad selection
- Take the number [1] for inner diameter for installation hole of shaft pad on left side of upper crankcase into record. As picture shows (Number on left side of upper crankcase (1 or 2). Which means the number for inner

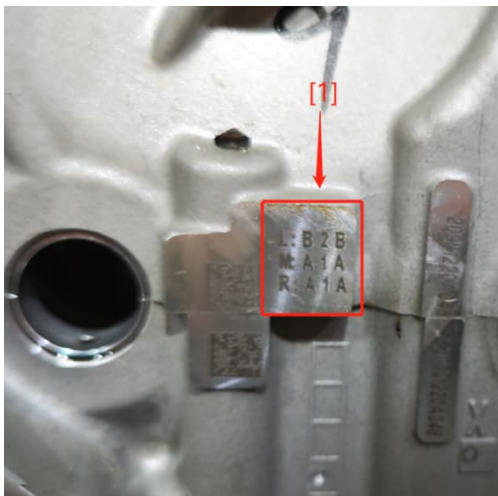

- In case the crankshaft needs be replaced, take corresponding number [1] on counterweight piece on crankshaft into record
- Select the color [1] for shaft pad by referring number for installation hole of shaft pad and journal for main shaft mutually.

- In case oil clearance passed maintenance limit, choose the correct shaft pad for replacement.

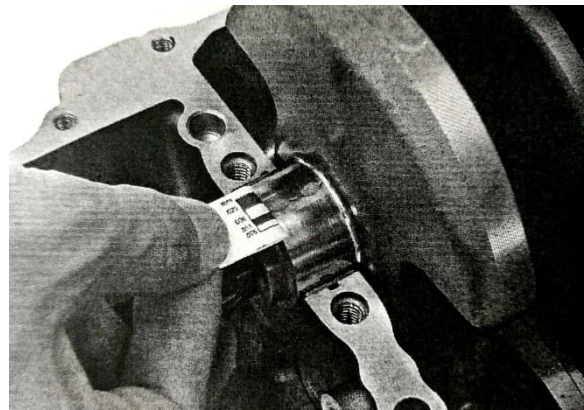

diameter of installation hole for shaft pad from left to right).

(The number on counterweight of crankshaft (1 or 2) means the sequence of number for outer diameter of journal for main shaft from left to right).



- Re-assemble the shaft pad with groove into upper crankcase, the shaft pad without groove assembled into lower crankcase.

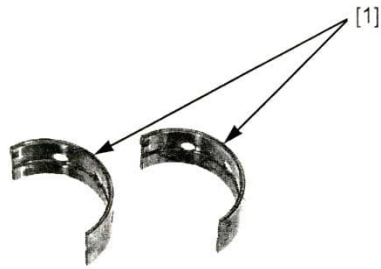

- Form list for matching-up of journal for main shaft:

- Form list for matching of crankshaft journals and shaft pad and crankshaft hole				
- crankshaft hole	- 1	- 1	- 2	- 2
- crankshaft journals	- 1	- 2	- 1	- 2
- shaft pad (upper)	- Yellow	- Yellow	- Green	
- shaft pad (lower)	- Yellow	- Green		- Green

- Caution: When new shaft pad selected, measure clearance once again by plastic gap gauge.

- Re-assemble shaft pad
- Clean up outer surface of shaft pad and installation hole for shaft pad on crankcase.
- Re-assemble shaft pad [1] for journal of main shaft into its installation hole on crankcase, align each protrusion to groove. Make sure press-fitting in place. The shaft pad could not extend out of contact surface of crankcase.

## - Shaft pad for crankshaft

- Caution: *engine damage.*
- Please don't change the position of shaft pad. The shaft pad must be assembled in its initial position, otherwise the oil film clearance will be wrong, which lead to

- Remove crankshaft
- Check if there is wear-out or spalling for shaft
- pad [1] of connective rod.
- Check if there is damage on protrusion [2] of shaft pad.
- In case the shaft pad for connective rod gets damaged, select shaft pad for replacement.
- 
- 
- Check oil clearance
- Remove crankshaft.
- Wash contact surface between bigger end of
- connective rod and rod cover by cleanser,
- then dry it up by compressed air.
- 
- 
- 
- Wipe up all the oil on shaft pad and crank
- shaft pin.
- Re-assemble crankshaft into upper crankcase.
- Assemble bigger end of connective rod into



- Re-assemble connective rod cover when the cover and bigger end are correctly matched and confirmed. Coat the threaded part of nut for connective rod cover with oil. Pre-fasten bolt for cover by 3-4 thread, make sure the cover of rod contacted the rod.
- Caution:意:
- *Make sure each part is re-assembled back to*
- *initial position as the same to marking-up*

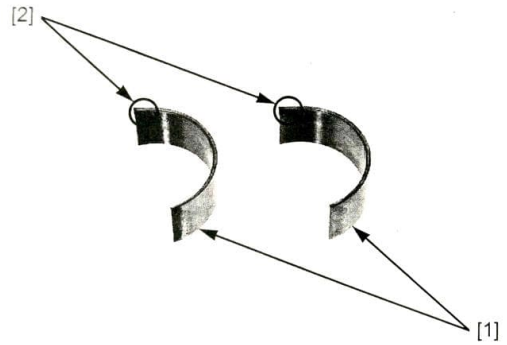

- crankshaft pin.
- Vertically lay a plastic gap gauge [1] on each
- journal of main shaft bypassing oil hole
- (Please don't turn crankshaft during
- inspection for oil clearance).
- 
- *when removing.*
- 
- 



100° for further strengthening.

- Torque: 20N•m
- Remove connective rod cover.

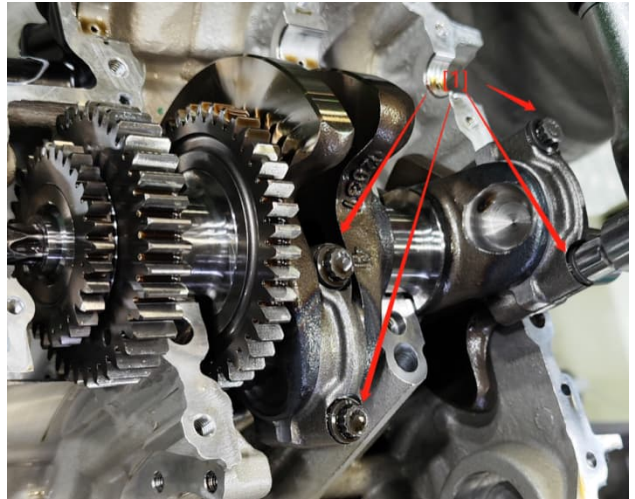

- Re-assemble and fasten bolt [1] for connective rod cove, then alternatively fasten to given torque by 2-3 times.

- Turn the bolt for connective rod cover by

- Measure each squeezed widest width of plastic gap gauge on crankshaft pin to confirm the oil clearance.

- Maintenance limit: 0.065mm

- In case the oil clearance passed maintenance

- limit, please choose the correct shaft pad for

- replacement.

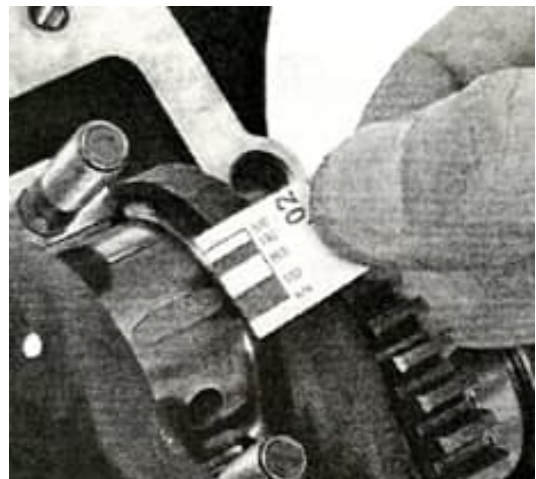

- Selection for shaft oad

- Take number [1] at inner diameter for connective rod cover into record (The number on bigger end of connective rod (A or B) means the number for inner diameter for bigger end of connective rod), or assemble the

cover onto connective rod, measure inner diameter without shaft pad.

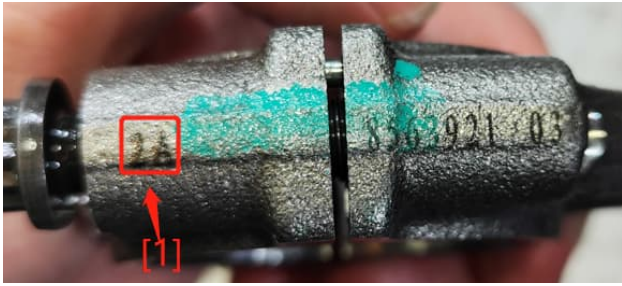

- measure
- its outer diameter by micrometer.
- 
- 
- Mutually refer number for connective rod and
- crankshaft to select shaft pad color [1] for
- replacement.

- In case crankshaft needs be replaced, take corresponding number [1] on counterweight of crankshaft into record (The letter number on counterweight of crankshaft (A or B) means number sequence of outer diameter for crankshaft pin from left to right).
- In case repeatedly use crankshaft,

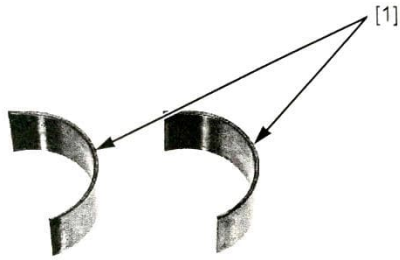

- Form list for matching-up of shaft pad for connective rod:

- Form list for matching of crankshaft journals and shaft pad and connective rod hole				
- connective rod hole	- A	- A	- B	- B
- crankshaft journals	- A	- B	- A	- B
- shaft pad	- Red	- Brown		- Blue

- Caution: When new shaft pad selected, please measure clearance by plastic gap gauge once again.
- 
- 
-

- 
- 
- 
- 
- 
- 
- 
- Re-assemble shaft pad
- Clean up outer surface of shaft pad, connective rod cover and bigger end of rod.
- Re-assemble shaft pad [1] for crankshaft pin into bigger end of connective rod, align each protrusion to groove. Make sure press-

- fitted
- in place, the shaft pad could not extend out of contact surface of crankcase body.
- 
- 

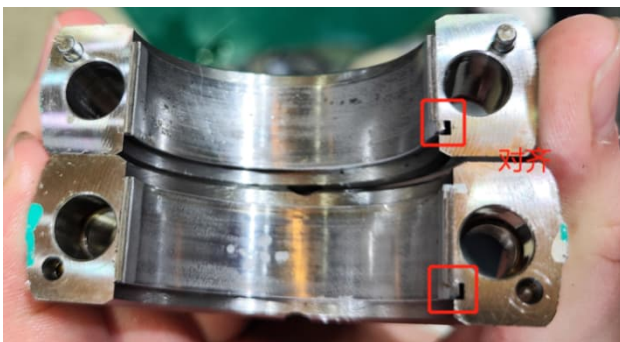

## Piston/Cylinder body

- Removal for piston/Connective rod kit
- Caution:
  - Before removing piston, wrap bigger end of connective rod by a clean fiberless fabric to prevent damaging cylinder hole.
  - Please don't try to remove piston/connective rod kit from bottom of cylinder hole, which will be seized up at joint between cylinder sleeve and upper crankcase body.
  - Please don't change the position for shaft pad, the pad must be re-assembled back to initial position, otherwise the oil film clearance will be wrong, which lead to engine damage.
- 
- 
- Removal for piston
- Remove circlip [1] of steel wire by

- Remove the parts below:
  - Front balancing shaft
  - Crankshaft
- Remove piston/connective rod kit [1] from top of cylinder body.
- 

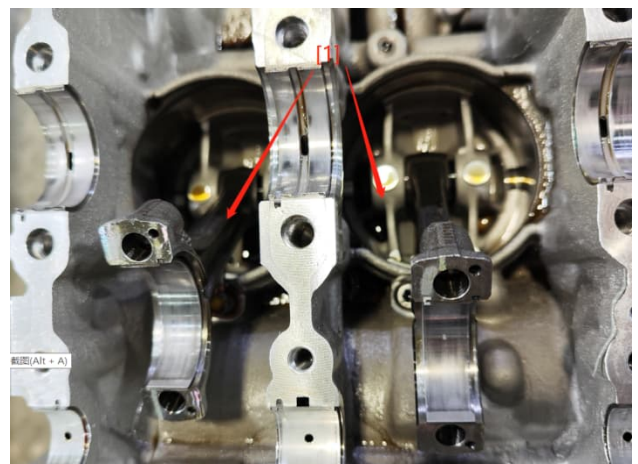

- tweezers.
- Push out piston pin [2] from piston [3] and smaller end [4] of connective rod, then

remove the piston.

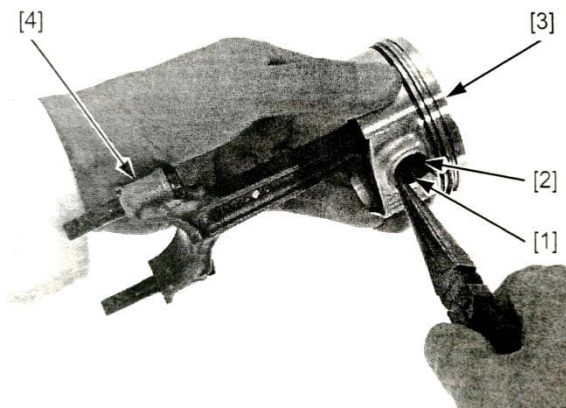

### Removal for piston ring

- Get opening for each piston ring apart, then
- remove the ring upwards along the opposite position to opening of piston ring.

- Clean up carbon buildup in groove of piston ring by piston ring which is about throwing away.

- Caution:
  - Please don't use steel brush to avoid scratching groove of piston ring.

### Inspection

- Check if there is scratch, damage, wear-out, distortion, burn-out or oil passage blocking-up on parts below.
- Cylinder body
- Piston
- Piston ring
- Piston pin
- Smaller end of connective rod
- Measure each parts according to
- Technical specification for
- crankshaft/piston/cylinder hole/balancing shaft

### Re-assemble piston ring

- Totally clean up groove of piston ring then re-assemble piston ring.
  - Coat the complete surface of piston rings and their grooves with engine oil.
  - Please don't damage piston and its rings during re-assembling.

- Caution:
  - Please don't separate the opening apart too far to prevent damaging the piston ring.
  - Please avoid scratch on piston when removing its rings.

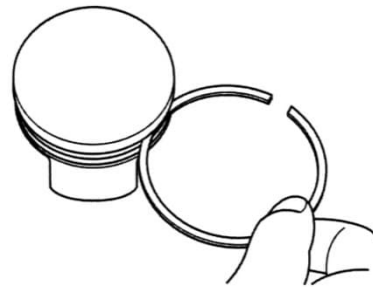
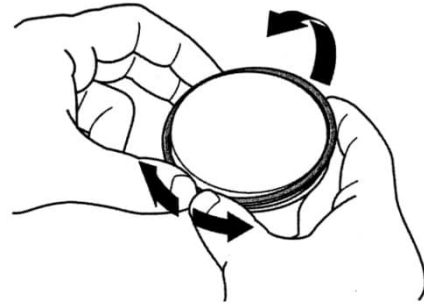

- and calculate their clearance.
- Any parts passed maintenance limit must be replaced.

- When re-assembling, get the side of piston ring with color mark face upwards.
- When re-assembling oil ring, assemble liner ring first, then the scratching ring.
  - Get the crossing angle of opening between the 1<sup>st</sup> /2<sup>nd</sup> ring mutually by 180°. As picture

shows.

- Dislocate opening of scratching ring for



### Re-assemble

piston

- Re-assemble shaft pad of crankshaft pin back to its initial position (Page 14-13).
- Coat internal surface of hole for piston pin with oil.
- Coat internal surface of smaller end of
- 
- 
- 
- 
- 
- 
- 
- Coat external surface of piston pin with oil.

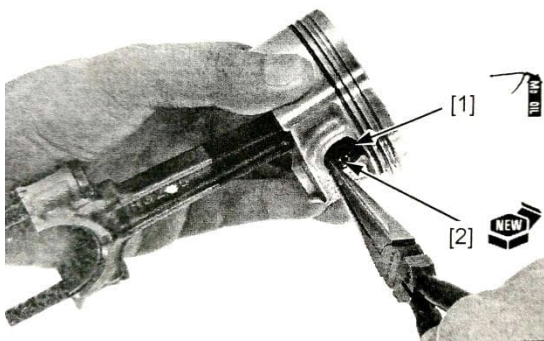

- Coat cylinder wall and thrust surface of piston with oil.
- When re-assembling piston/connective rod kit[1] into cylinder hole (When re-assembling piston/connective rod kit, the mark "Arrow" on piston face to direction of air intake).

crossing angle by 120°.

- connective rod with oil.
- When matching up piston [1] and connective rod [2], get protrusion [3] for shaft pad of crankshaft pin facing to mark [4] of "IN" on piston.

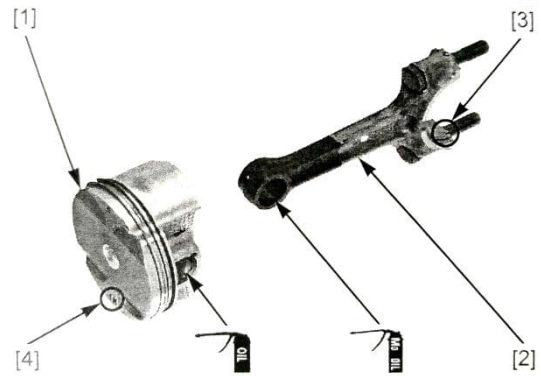

- Re-assemble piston pin [1], then fix it by new circlip [2] of steel wire.
- Caution:
  - Make sure circlip of steel wire assembled in place.
  - Please don't align opening on circlip to gap on piston.

- When repeatedly using connective rod, they must be re-assembled to their original position.
- Caution:
  - *When re-assembling piston, please don't damage its top surface, especially don't damage matching place to cylinder hole.*

- *Please don't damage cylinder sleeve and crankshaft pin by connective rod.*
- Slightly knock piston into cylinder body by plastic hammer (Make sure compressing tools for piston ring is flatly put on upper surface of cylinder body).
- Re-assemble parts below:
  - Crankshaft
  - Balancing shaft



### - Oil nozzle for piston

- Removal/Re-assembly
- Remove piston/Connective rod.
- Loosen bolt for nozzle and remove the nozzle
- (Please don't damage hole for oil nozzle).
- Totally clean up nozzle by solvent.
- Check if the nozzle is blocked up, please replace for a new one if it is necessary.
- Clean up oil passage for upper crankcase and nozzle.
- Re-assemble nozzle into upper crankcase until it completely in place. When re-assembling, align protrusion of nozzle to groove on crankcase.
- Re-assemble removed parts according to opposite sequence to removal.

### - Rear balancing shaft

- Removal
- Remove lower crankcase body.
- Remove bolt [1] and shaft pad cover [2].

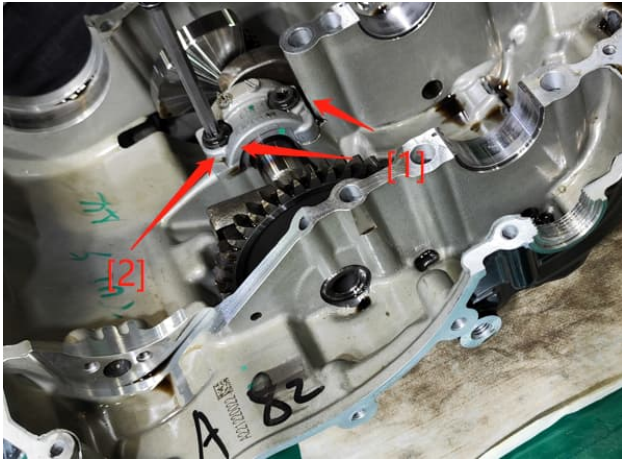

- Remove bolt [1] for shaft jacket of rear balancing shaft and the shaft jacket [2].

- Remove rear balancing shaft [1] and driving chain [2] of oil pump.

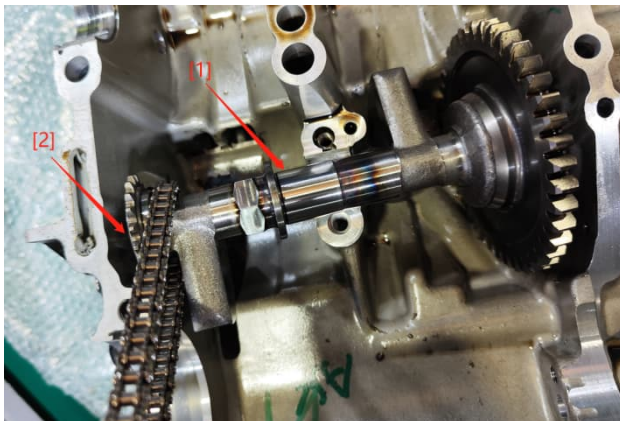

### Inspection

- Check if there is scratch, damage, wear-out or distortion on parts below, replace if it is necessary.
- Driven gear for balancing shaft
- Counter gear for driven gear on balancing shaft.
  - Pressure spring for driven gear
  - Balancing shaft
- Bearing for balancing shaft
- Re-assembly.
- Coat shaft pad and jacket of balancing shaft with oil.
- Re-assemble balancing shaft [1] into upper crankcase, then assemble shaft jacket [2] for balancing shaft.

