



VOGE

Far & Beyond Quality

MOTORCYCLE OPERATION MANUAL

DS900X



Welcome to VOGÉ

We say thanks and express our congratulations to your correct choosing on VOGÉ.

You need to know your motorcycle as well as yourself, to safely drive under various conditions. Please carefully read this book before your first driving, which includes important information and suggestion about driving and its equipment, also the maintenance and pre-cautions. In case there are some questions about this motorcycle, the VOGÉ dealers are very glad to suggest and help you. We hope you enjoy your every minute on driving.

Important information about this book

This book includes the important information, issues need pay attention to, warning and cautions about the motorcycle, so please always keep it on the motorcycle even lend or sell to others, this is very important. The pictures or details in this book may be different with the actual motorcycle, but their description and principle are the same. This book is a part of the motorcycle, keep it always on the vehicle even sell or lend. VOGÉ improves its products all the time to make sure its high quality and safety performance, so the information in this book may not be complete same with your actual motorcycle, in this case, the VOGÉ dealers are glad to provide your correct suggestions.

The standard of execution: Q/LX 1053-2024

This user manual meets the standards: GB/T 19678.1、GB/T 9969、GB/T 40494

All rights of final interpretation belong to Loncin Motor co.ltd.

Content list

I. Issues need pay attention to	1	Socket for USB power supply	41
II. Safe driving	2	ABS system	42
Loading, accessories and refit	2	TCS traction control system	43
Checking before driving	3	Quick gearshift system (Some models equipped)	43
Issues need pay attention to during driving	4	Cruise control system	44
Driving on road	5	Radar (Some model equipped)	45
Braking and parking	6	Gearshift device	47
III. Main parameters	7	Side stand and main stand	48
IV. Structure of motorcycle	8	Rear brake pedal	48
Identification for motorcycle	8	Engine starting	49
Head part	9	Fuel filling-up	50
Left side	10	VI. Malfunctions	52
Right side	11	Too hot the coolant	52
Lower side of seat	12	Insufficient coolant	52
V. Operation	14	Malfunction in engine system	52
Ignition switch	14	Engine starting failure	53
Instrument and its indicating light	16	Difficult engine starting	53
Installation and usage instructions for VOGE Global APP	23	Weak engine power	53
Introduction for instrument operation	29	Malfunction inspection and repair	53
Steering set switch	36	Grinding-in for new motorcycle	54

Grinding-in for engine	54	External power supply.....	66
Grinding-in for tire	55	Maintenance for air filter.....	67
Grinding-in for brake system.....	55	Oil in engine	68
VIII. Adjustment	55	Replacement of oil filter.....	72
Adjustment for back-view mirror.....	55	Coolant	73
Adjustment for clutch lever	56	Brake liquid.....	76
Adjustment for gearshift pedal	56	Driving chain	77
Adjustment for rear brake pedal	57	Tire.....	78
Adjust front shock absorber.....	58	Fuse box	80
Adjust rear shock absorber.....	59	Relay.....	81
Adjustment for headlight dimmer ...	60	Brake pad	82
Turning auxiliary light.....	60	Replacement for lighting signal.....	83
Adjustment for transmission chain....	61	Maintenance plan	84
IX. Check, repair and maintenance	62	X. Maintenance for the motorcycle in long parking .	86
The fuel	62	Storage for motorcycle	86
The fuel evaporation	63	Protection for motorcycle.....	87
Tool kit.....	64	Cleaning up for motorcycle	87
Moving parts and their maintenance .	64	XI. Electrical diagram	88
battery.....	64		
Disassemble and re-assemble battery.....	66		

I.Issues need pay attention to

This user manual has the warning marks as below, when you saw it, please follow these driving and maintenance procedure.

 **Danger** This mark indicates it may lead to bad injury even death.

 **Warning** This mark indicates it may lead to damage on motorcycle.

 **Caution** This mark means more effective and convenient point for driving.

Danger

This book fits for the driver with license only, please correctly and cautiously drive and pay attention to:

Refit at will is not allowed;

Please follow the local laws and regulations;

Any refit on this motorcycle may be bad for noise, emission and performance.

Because we keep improvements on motorcycle, so the actual motorcycle may not be complete same with !this book, please set the actual motorcycle as standard while without further information.

II.Safe driving

Loading, accessories and refit

You can get the origin VOGÉ and authorized parts, accessories and other products from our official dealers, meanwhile, the specialized workers will introduce you how to use and assemble.

Please always adopt origin VOGÉ parts or our authorized ones. The parts nor from VOGÉ factory, incorrect accessories or loading are bad for motorcycle performance even break laws, please take responsibility for your safety and that of others.

Caution

- The parts this model equipped have passed the test for safety, practicability, and matching performance, and we take responsibility for them, otherwise, we have no responsibility for the parts not from us or without our authorization. So we strongly suggest you adopt the parts and accessories from VOGÉ factory only.
- All your replacement for parts must obey local laws. Make sure your motorcycle won't break any laws and regulations

Danger

- Incorrect loading, refit, accessories and maintenance are all hidden risk, before driving, make sure there is not any overloading and obey the stipulations above.
- Refit the electrical or controlling parts at will may damage your motorcycle even lead to accident.

Change the curb weight of motorcycle may be bad for its power performance, so please surely adopt the cargo weight, passenger numbers and accessories from our suggestion only.

Checking before driving

Before driving, make the inspections as below to reduce accident or damage:

•Steering system

- Handle bar turns freely without jamming.
- No run-out or flexibility on steering stem

•Throttle

- Correct clearance for throttle cable.
- Operate throttle smooth without jamming.

•Brake device

- Operate brake lever and pedal normal.
- Correct position of brake liquid in oil cup.
- Pressing point if clean during braking process.
- Not water or greasy dirt on brake plate or pads.

•Shock absorber

- Press it and get back smoothly.

•Transmission chain

- Without too much abrasion or damage.
- Tightness is correct.

•Tires

- Correct tire pressure.
- Without too much abrasion for depth of tire tread.
- No damage or crack on surface of tire.

•Oil in engine

- Correct oil level.

•Cooling system

- Correct coolant level.
- Without coolant leakage.

•Lighting

- Headlight/Front position light, tail light/brake light, turning signal light, rear registration plate light and instrument light could normally work.

•Indicating light

- Control high beam indicator light, neutral indicator, and indicator light for turning signal light by switch assembly, which could normally work, and indicator light for engine malfunction, water temperature alarm light, and fuel level alarm light are not blinking or steady on when engine started.

•Horn

- Normally works.

•Kill switch of engine

- When engine started, which could be stopped by kill switch.

•Side stand

- Normally pick up.
- Interlocking function with ignition is normal.

•Back-view mirror

- Sit on motorcycle and keep it upright, the material 10m to tail of motorcycle within width of 4m could be clearly seen from back-view mirror.
- In case failed, please adjust the angle of back-view mirror.

•Shock absorber

- Press it down then it returns smoothly;
- There is not mud, sand or ice on surface of fork tube.

•Turning damper

- Turn the handle bar left and right to check if the turning damper is jamming;
- There is not any mud, sand, or ice on surface on connective rod of turning damper.

Issues need pay attention to during driving

1. Any driver must know well about the motorcycle, the incorrect sitting position or off set during driving may be bad for operation or control of motorcycle; When driving, the passenger need. stably sit on his seat without influence driver. Passenger is an animal is not allowed.
2. Keep the luggage low to decrease the influence on focus, also the weight of luggage needs evenly spread on both sides, please avoid the luggage extend too long.
3. The luggage must fix on the motorcycle firmly, make sure it could not move before driving, in case it is unstable in driving, please check its fixing once again, and adjust if it is necessary.
4. Too heavy or big the luggage is not allowed, the overloading must be bad for driving and performance.
5. The accessories or luggage may decrease motorcycle performance shall not be loaded, make sure all what you do may not be bad for lighting system, ground clearance, brake performance, side angle, operation, compression distance of tire, working travel for front shock absorber or other performance related to driving.
6. More weight on handle bar or front fork may be and for turning, and lead to unsafe driving.
7. Fairing cover, wind shield glass, backrest or other parts with big size may have influence on stability or operation during driving, they increased not only the weight, but also the size, which lower down the power. In case their design lack of test, they may lead to unsafe driving.
8. Refit to tricycle with side car is not allowed, drawing for other vehicles is also not allowed, and we take no responsibility for refit without authorization.
9. When driving in high and cold condition, check if there is ice on surface of connective rod for turning damper before every driving, in case there is, please wipe up by clean tissue without dust and dirt.
10. When the turning damper worked 24 hours later, please timely clean up the surface of connective rod, to prevent mud or sand get into damper that makes it fail.

The maximum loading: 205kg, (including driver, luggage, and accessories).

Driving on road

- Get on the motorcycle from left side and ride on.
- Pick up the side stand.
- Get the motorcycle upright to the ground, get the handle bar face front, keep its wheel face forward.
- Tightly hold the clutch lever.
- Slowly turn the throttle grip to accelerate, while slowly releasing the clutch lever, clutch meshed, then motorcycle slowly start.
- Wear helmet, gloves, driving boots, protective wear and pans before driving even only for a short driving.
- In case you drive fast, please pay attention to the factors below which bad for your driving.
 - Loose cloths – Incorrect adjustment for spring of shock absorber.
 - Overload or imbalance load may be bad for your driving and controlling.
 - Don't drive after drink wines, drugs even medicines, even a few alcohol or medicine is bad for your sense and reflection.

Caution

This model equipped inter-lock switch for side stand/ignition switch, once engine is in a gear position not the neutral one, lay down the side stand, engine stops immediately.

Warning

Start engine from high gear position is not allowed, otherwise it may damage engine, Please start engine from 1st gear.

Danger

Before starting, please pick up the side stand to top position, otherwise, when you turning left, the side stand may touch the ground and lead to accident.

Braking and parking

- Please decelerate first when braking to reduce the speed and use the front and rear brake at same time.
- When the driving speed is low enough, get into low gear position, and tightly hold clutch lever.
- Get the engine into neutral gear, the motorcycle brakes and completely stops.
- When braking, your body get front and press down the front shock absorber, so there is more weight suddenly focus on the front wheel, so the front brake is more reliable, so the front brake is more powerful than the rear one and more easily get motorcycle stop.
- When you are driving on maintain way, use the rear brake only is dangerous, under some limit conditions, the brake may overheat and damage, please use the front, rear brake sand engine coordinately to decelerate.
- Driving in water and rain, the brake plate may get wet and reduce its braking performance, be careful under this situation. Under this case, we suggest you dry it up and then continue the operation.

Warning

- After a long driving, when parking, because the engine is very hot at this moment, so keep it far away from kids to avoid hurt.
- Don't park the motorcycle on soft ground to avoid rollover even damage the motorcycle.
- in case parking on a gentle slope, get the engine into low gear position, let its head face to uphill to avoid the turning of side stand and rollover.
- Parking or running on combustible materials such as dry grass is not allowed, because the three-way catalyzer is working under very high temperature which is very easy to light up the combustible materials.
- When there is a sudden braking and driving speed is $\geq 50\text{km/h}$, the ESS system may control the braking light and make it quickly blink, which remind the vehicle behind to pay attention to rear-end collision.

III. Main parameters

Parameters for motorcycle		Engine parameters	
L x W x H	2325mm x 940mm x 1420mm	Engine type	Twin-cylinders in line/Water cooled/4 valves
Wheelbase	1580mm	Bore x stroke	86mm x 77mm
Seat height	835mm	Displacement	895ml
Ground clearance	210mm	Compression ratio	13.1:1
Curb weight	238kg	Air intake valve clearance	(0.11-0.20)mm
Loading	205kg	Air exhaust valve clearance	(0.26-0.35)mm
Max. weight	443kg	Spark plug clearance	0.8mm-0.9mm
Front wheel hub loading	161kg	Spark plug specification	LMAR9J-9E
Rear wheel hub loading	282kg	Max. net power/rotation	70.0kW/8250rpm
Max. designed speed	210km/h	Max. torque/rotation	95.0N.m/6000rpm
Max. gradeability	≥ 44°	Idling rotation speed	(1250±100)r/min
Braking deceleration	Execute according to GB20073-2018	Gearbox type	International 6 gears
Fuel consumption	≤ 5.3L/100km (According to GB15744-2019)	Clutch type	Wet multiple layers
Fuel tank capacity	17L	Oil capacity	3.2L
Coolant capacity	2L	Fuel supplying system	EFI system
Chain specification	525UXI (122 links)	Emission standard	Euro 5
Suspension/Brake system		Transmission system	
Front shock absorber type	Up side down shock absorber/Fork tube of φ43mm with free play of 194mm	Primary transmission ratio	1.821
Rear shock absorber type	Central shock absorber/Free play of 63mm	End transmission ratio	2.588
Front wheel hub specification	2.15 x 21	1 st gear	2.833
Rear wheel hub specification	4.25 x 17	2 nd gear	2.067
Front tire size	90/90-21 M/C54V	3 rd gear	1.6
Rear tire size	150/70 R17M/C69V	4 th gear	1.308
Front brake	Double plate, dual pistons, floating caliper, floating plate/Plate diameter of 305mm	5 th gear	1.103
Rear brake	Single plate, single piston, floating caliper, fixed plate/Plate diameter of 265mm	6 th gear	0.968
ABS	ABS system with dual passage		

IV. structure of motorcycle

Identification for motorcycle

The Vehicle Identification Number (VIN) and name plate Engine type number and Delivery number

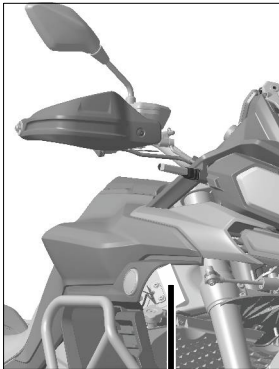

Vehicle Identification number

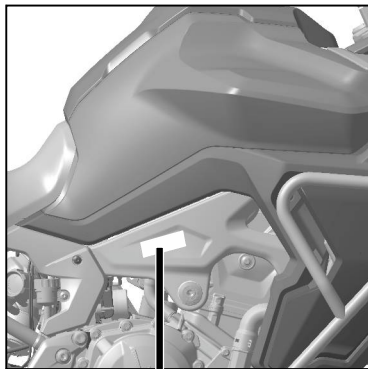

Products number

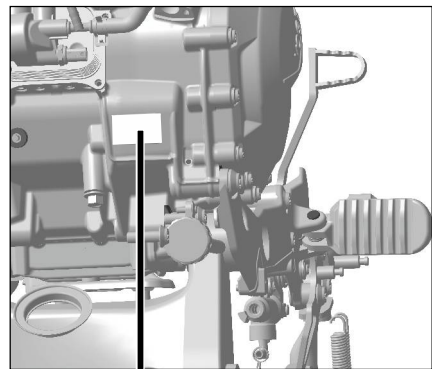

Engine type and Delivery number

Head part

1. Left handlebar cover
2. Left rearview mirror
3. Left brake lever swit
4. Instrument
5. ignition switch
6. DC socket
7. Front brake oil cup
8. Right brake lever swi
- and fuel dispenser seat
9. Right rearview mirror
10. Right handlebar cov
11. Front brake handle
12. Fuel dispenser
13. Fuel tank cover
14. USB power interface
15. clutch handle
16. Left handlebar

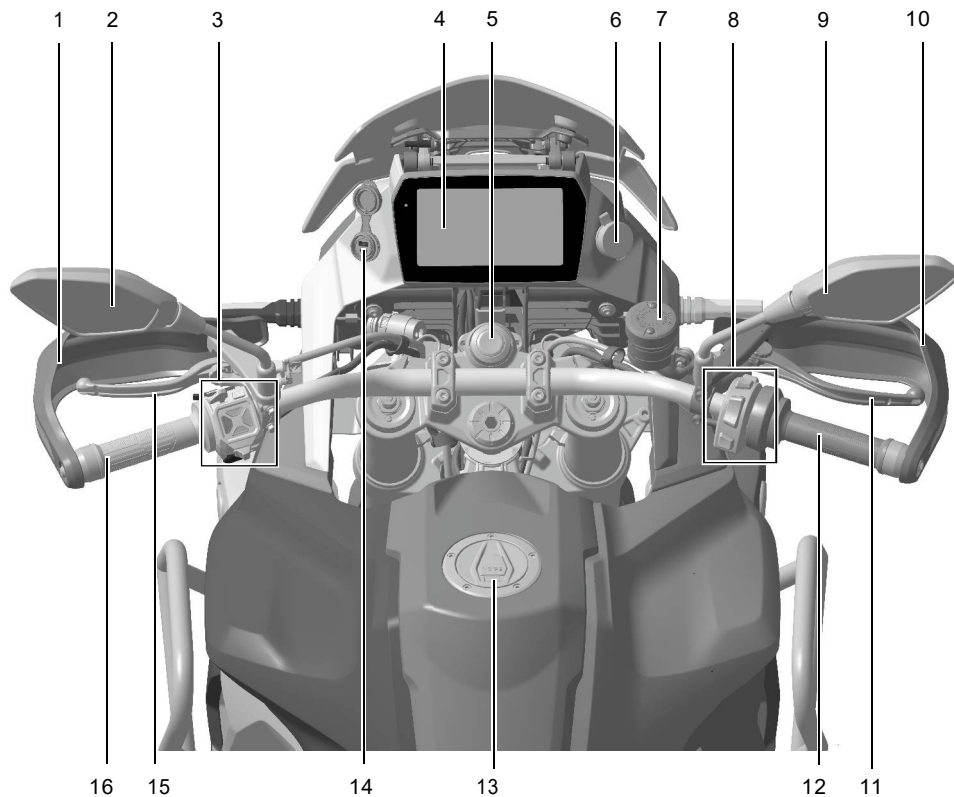

Left side

1. Headlight/front position lamp
2. Left front turn signal lamp
3. Rearview mirror
4. Fuel tank
5. Oil filler and dipstick
6. Quick trend shifter
7. Main seat cushion
8. Left rear turn signal lamp
9. Brake light/rear position lamp
10. Rear license plate lamp
11. Rear retro reflector
12. Chain adjuster left
13. Main station frame
14. Left auxiliary footrest
15. Chain guard
16. Side bracket
17. Left main footrest
18. Side bracket ignition switch
19. Transmission pedal
20. Left bumper
21. Left front fog lamp
22. Steering damper
23. Front disc brake lower pump
24. Front disc brake disc left
25. Left reflector

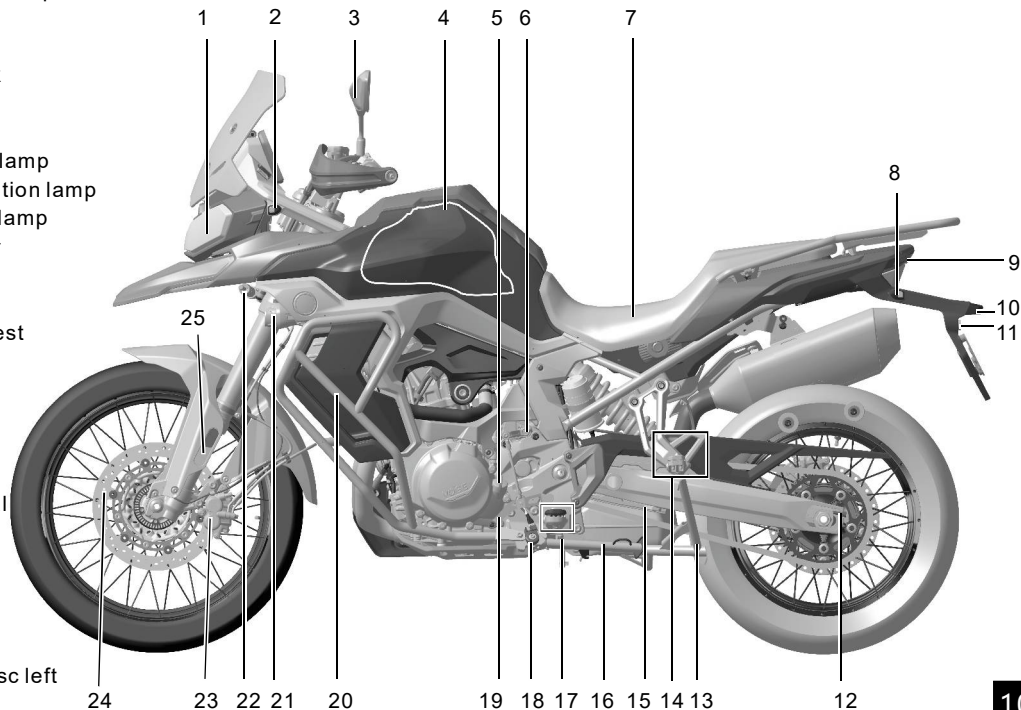

Right side

1. Passenger armrest
2. Pressure regulating rectifier
3. Rear brake oil cup
4. Right bumper
5. Right front turn signal
6. Right front fog light
7. Right reflector
8. Front disc brake disc right
9. ABS ring gear
10. Front disc brake lower pump
11. Cooling water tank filling port
12. Oil filter
13. Right main footrest
14. Right auxiliary footrest
15. Muffler
16. Rear disc brake lower pump
17. Rear disc brake disc
18. Chain adjuster right
19. Right rear turn signal light

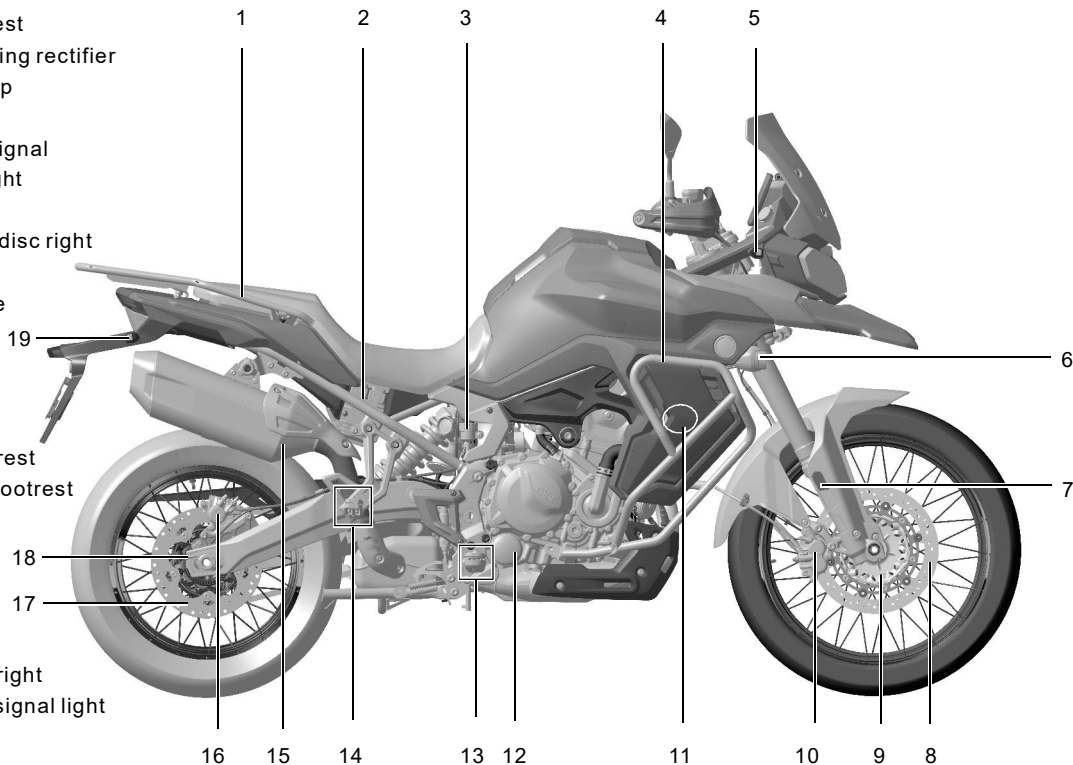

Lower side of seat

1. Start relay
2. IMU controller (some models have it)
3. Battery
4. Dash cam (some models have it)
5. Electronic controller ECU
6. Diagnostic interface
7. BCM controller
8. Seat cushion lock
9. fuse box
10. on-board tools

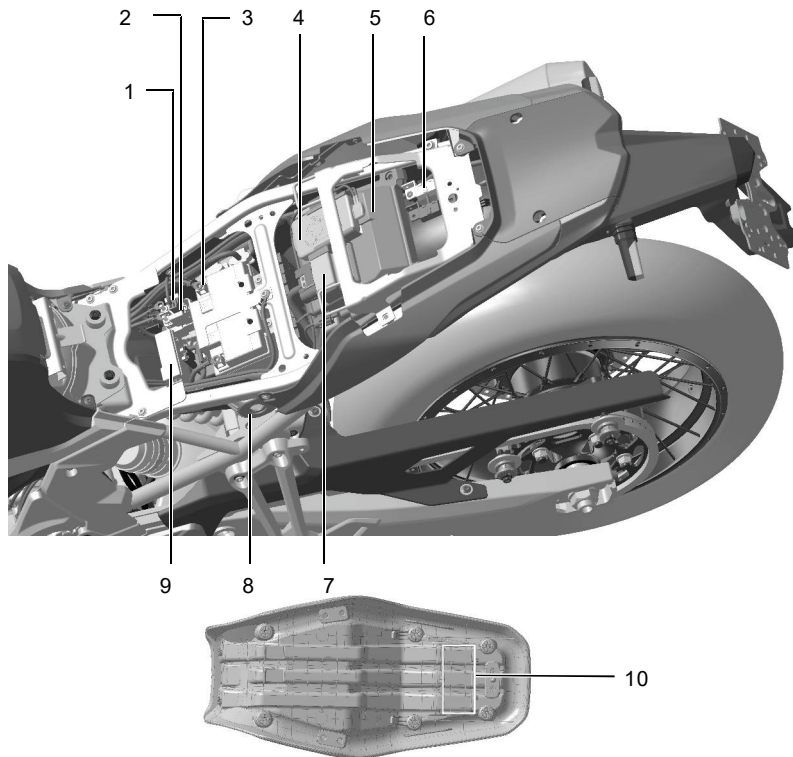

Schematic diagram of insurance and control relays

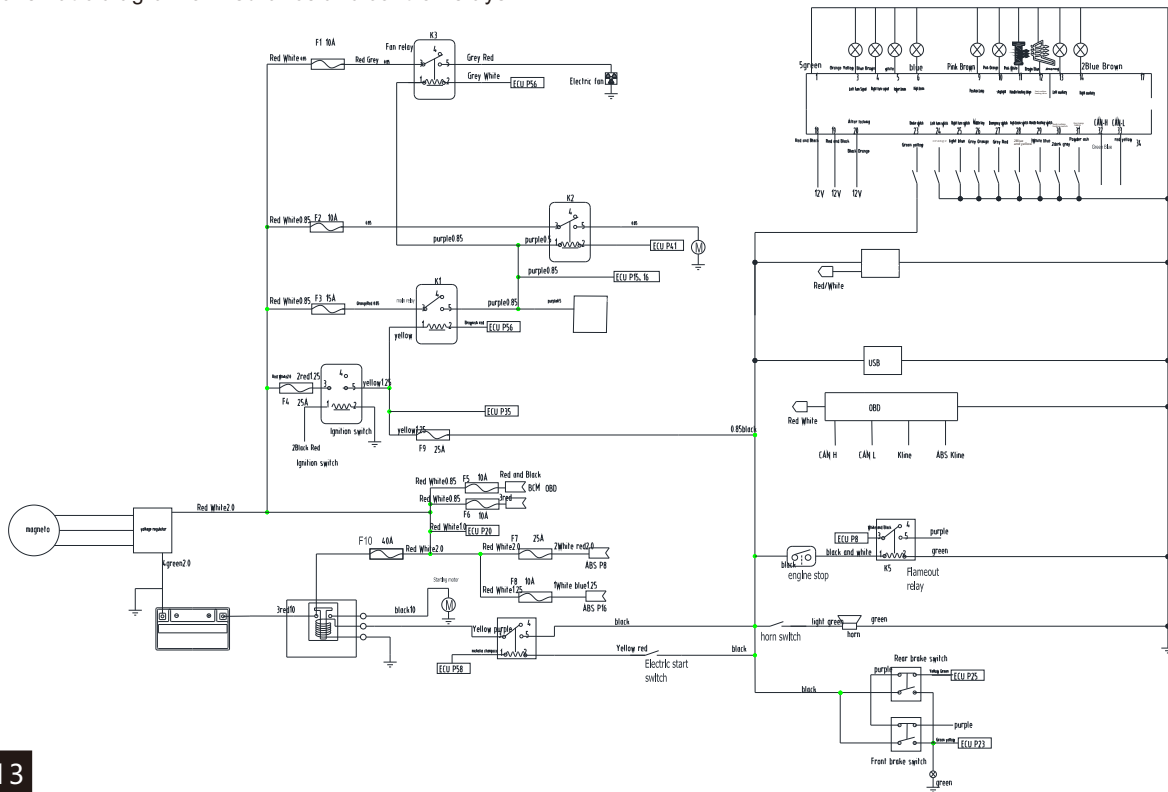

V. Operation

Ignition switch

The ignition switch of this model is on the upper connective plate. This model equipped one key (Include a mechanical key, on the remote control key, the left button is for searching, short press is searching, the turning signal of model flashes 10 times, in the open field, the distance for searching is 30m, in case not in open field, its distance may be shorter than 30m), this model also equipped a spare key, please keep the spare key in place separately. The seat lock and fuel tank lock share a same key.

1. When vehicle is in using, the distance from remote key to ignition switch shall not be more than 1.3m.
2. When the vehicle is power off, long press ignition switch can lock up the head part of motorcycle, then slightly turn the head part to confirm if it was well locked up.
3. When wheel was turning, the head part of motorcycle could not be locked up.
4. When locking up the head part, the head part of motorcycle need be at the most left, otherwise the head part could not be locked up.
5. When the motorcycle needs be power on, in case at the moment the head part is locked, short press ignition switch, the head part will be unlocked, then short press once again the motorcycle may be power on.
6. When the head part is locked up, long press ignition switch over 3 seconds, the unlocking and power on will be done in a same operation.
7. When motorcycle was power on, the blue indicating light on ignition switch will be on by keeping 1 minute.
8. When the remote key's power ran out, get the remote key or the spare on close to indicating light ring, meanwhile short pressing ignition switch to get motorcycle power and start engine within 1 minute, otherwise the motorcycle will get power off automatically.
9. When the speed of motorcycle is 0, in case power off the needed, please short press ignition switch, in case long press ignition switch by 3 seconds, the power off and locking up of head part will be got in a same operation.
10. In case the wheel speed is more than 0, short press ignition switch won't get motorcycle power off.
11. Even within the distance of 1.3m to ignition switch, put remote key at some places on motorcycle, may get abnormal communication between remote key and motorcycle, these places are but not only seat, surroundings of steering stem, and the front of meter set.



12. Troubleshooting for ignition switch.

(1) Failure of motorcycle power on.

When short press ignition switch, check the reminder from indicating lights of ignition switch and remote key.

The red light flashes for 3 times on ignition switch means feeling failure for key, whose possible causes are:

-The distance from remote key to ignition switch is longer than 1.3;

-Disturbed by strong wireless power around, get the key closer and get motorcycle power on.

-The power of remote key ran out, at this moment, press the button on remote key, whose brightness is obviously dark, take the key close to indicating light ring of ignition switch to get motorcycle power on. In case get motorcycle power on in this way, the engine could be started unless the key without leaving ignition switch. Then the key could get apart from ignition switch, and the motorcycle could normally work. When the motorcycle got power on, the key is sticking on ignition switch without other operations, the motorcycle may keep its power on, then the engine could be started. But in case the motorcycle was power on, the key is sticking on ignition switch but the engine without starting, 1 minute latter, the motorcycle may get power off automatically. Get the key close to ignition switch and engine already started, then get the key apart ignition switch, press button of electric starting/kill switch of engine, the motorcycle may get power off automatically.

(2) The steering lock doesn't work

-In case the locking tongue failed extending out, check if the fuse already burned out. In case the fuse is normal, please contact the service station for after-sales.

Caution

This model equipped both main and side stand, when the motorcycle was parking by side stand, for its stability, please turn the head part of motorcycle to its left limit but not right limit and lock up the steering stem, In case the red indicating light on ignition switch flashes for 3 times, which means there is malfunction in wireless communication between key and motorcycle, in case the red light flashes for 4 times, it means the anti-theft admission for engine failed, if the red light flashes for 5 times, which means the steering lock is abnormal.

Instrument and its indicating light

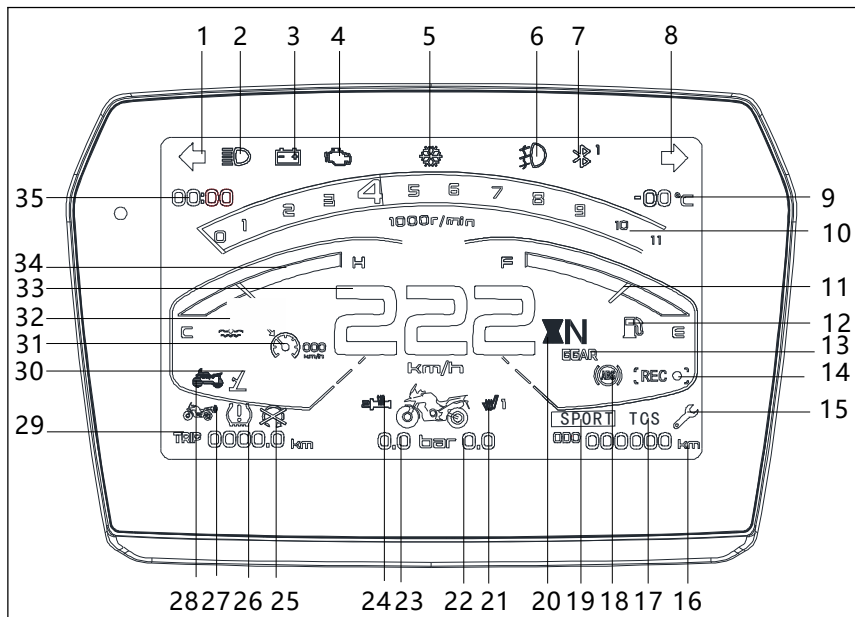

1. Left turn indicator light
2. High beam indicator light
3. Battery voltage warning light
4. Engine malfunction warning light
5. Environmental low temperature indicator light
6. Front fog light indicator light
7. Bluetooth connection display
8. Right turn indicator light
9. Environmental temperature display
10. Engine tachometer
11. Fuel gauge
12. Fuel warning light
13. Engine gear display
14. Driving recorder
15. Maintenance indicator light
16. Total mileage of the vehicle
17. TCS indicator light
18. ABS fault warning light
19. Mode indicator light
20. Up and down gear prompt
21. Seat heat up indicator light
22. Tire pressure in rear tire
23. Tire pressure in front tire
24. Grip heat up
25. Engine shutdown switch
26. Tire pressure alarm light



27. Radar (Some models equipped with)
28. Anti-theft reminder
29. Vehicle subtotal mileage
30. Indicator light for kill switch on side stand
31. Cruise control
32. Cooling liquid temperature warning light
33. Vehicle speed display
34. Water temperature gauge
35. Clock

When pressed button of ignition switch, the meter get power on and start self-inspection:



The display screen gets on and start self-inspection, show you the situation of motorcycle at the moment.

When engine is in malfunction, the alarm light"  "gets on; The alarm light for ABS malfunction"  " and indicating light for TCS slowly flashes.

Caution

Please don't wash the meter set by water stream of high pressure directly. Please don't wipe up the meter set by organic solvent such as gasoline or alcohol, otherwise it may create crack or color fading of meter set.

Left turning light "**"**

When pushing the turning signal switch on left switch assembly to left side"  ", whose indicator light "  " gets on.





Caution

When turning signal light damaged or failure caused by other malfunctions, the flashing frequency of "  " may get faster, which reminds you there is malfunction in turning signal light.



Neutral indicating light " N "

When the engine locating in gear neutral, its indicator light " N " gets on.

Engine malfunction alarm" "



When there is malfunction in management system of engine, its alarm light "  " gets on. When turned the key for ignition switch to position "  ", the indicator light"  " gets on; When engine started, the indicator light "  " gets off immediately.

Caution

In case the indicator light "" flashes or gets on when engine started, under this situation, keep driving may get ignition failure and fuel supplying system stop working. In case the indicator light "" steady on or flashes during driving, please stop driving immediately and contact dealer of VOGE.

Alarm light "" for ABS malfunction

When there is malfunction in ABS system, the indicator light "" gets on.

When pressed button for ignition switch, the indicator light "" is slowly flashing, when motorcycle got into normal driving, the indicator light "" gets off immediately.

Danger

In case indicator light "" gets steady on during driving, please stop driving immediately and contact dealer under VOGE as soon as possible.

Indicating light for ""

When motorcycle got power on, the indicator light "" is slowly flashing, and gets off when motorcycle got into normal driving.

When the TCS function is abnormal or turned off by driver, the indicator light "" keeps steady on. Every time when motorcycle got power on, the default for TCS is on.

When the TCS is on, in case the tire gets skidding during driving, the TCS may get torque down to reduce tire skidding, at this moment, the TCS is working, while its indicator light "" is fast flashing.

Warning

When TCS is on and during driving, in case its indicator light "" keeps steady on, which means there is malfunction in TCS system, under this situation, please contact dealer under VOGE immediately.

Right turning signal light" ⇨ "

When pushing the turning signal switch " ⇨ " to right, the turning signal light " ⇨ " gets on.

Caution

When the turning signal light on motorcycle damaged or failure caused by other malfunctions, the flashing frequency of this turning signal light " ⇨ " may get faster than normal situation, which reminds you there is malfunction in turning signal light.

High beam indicating light" ≡D "

When pushed the headlight switch on left switch assy. upwards, the indicating light " ≡D " gets on.

When pressed the overtaking light switch on left switch assy., "the indicating light" ≡D " gets on until you release the switch.

Tire pressure display and its alarm light

When pressure in front tire is <1.9 bar, the showing color for tire is red, while the alarm light is on, when tire pressure was > 2.0 bar, the showing color for tire is white, while its alarm light gets off.

When pressure in front tire is >3 bar, the showing color for tire is red, while the alarm light is on, when tire pressure was < 2.8 bar, the showing color for tire is white, while its alarm light gets off.

When pressure in rear tire is <2.2bar, the showing color for tire is red, while the alarm light is on, when tire pressure was > 2.3 bar, the showing color for tire is white, while its alarm light gets off.

When pressure in rear tire is >3.4 bar, the showing color for tire is red, while the alarm light is on, when tire pressure was < 3.2bar, the showing color for tire is white, while its alarm light gets off.

When it doesn't show you tire pressure but a red bar instead, which means there is malfunction in monitoring system for tire pressure, please contact the service station nearby.

Only when driving speed is higher than 25km/h and there is change of tire pressure, the tire pressure sensor may send wireless signals to its corresponding receiver.

The receiver for signal from tire pressure only works when engine started, in case no signal received, the meter may show you the white cross bar. The meter shows you the last data of tire pressure. In case the driving speed is lower than 25km/h, the tire pressure the meter shows you may not be the actual one, if there is change of tire pressure during this period, the actual tire pressure may not reflect on meter, for example parking, air charge or discharging, whose latest tire pressure may not reflect onto meter immediately, only when the driving speed was higher than 25km/h, the data for tire pressure will be updated.

 **Caution**

The tire pressure sensor of the specified model from the infinite original factory must be used.

When replacing the tire pressure sensor or ignition switch, it is necessary to re-match the tire pressure.

The matching method can be found in the instrument function introduction. When matching, please confirm the target wheel and the sensor ID number displayed on the instrument interface after matching to avoid errors in front and rear wheel recognition.

Displaying screen of TFT

When the meter is working: When it starts working, it shows you the setup for mode information of last time.

Light for background of meter: The meter shifts its light of background according to brightness.

Bluetooth connection: When the cell phone is connected through Bluetooth to meter, the icon of Bluetooth is lighting and could show you caller ID (Show you caller ID + Caller name).

Rotation speed: The rotation speed for engine.

(r/min-Rotation numbers/Minute-The current rotation circles per minute of crankshaft)

Driving gear position: The current gear position of engine. (Not neutral gear position).

Driving speed: The running speed of motorcycle. (km/h-Kilometers/Hour, or mph-Miles/Hour).

Water temperature: Show you the current coolant temperature. (Unit: °C, showing range is -48°C~143°C, when the coolant temperature is $\geq 112^{\circ}\text{C}$., the alarm light for coolant temperature gets on, and the displaying bar for temperature gets red completely. When the temperature is out of range of -48°C~143°C, the interface of " My motorcycle " show you --).

Fuel level: Show you the current level for residual fuel.

When the fuel meter show you there is only one cell, the alarm light for fuel level may change to amber, which reminds you a timely fuel filling-up.



 **Caution**

The fuel level may get waving during driving, when there is not so much residual fuel, it may lead to indicating bar flashing or sometimes not, which is normal situation, please don't worry. In case the alarm light for fuel level got amber, it means there is only about fuel of 3L in fuel tank.

 **Danger**

Please cautiously operate meters during driving, please it may reduce your control for motorcycle.

Installation and usage instructions for VOGE Global APP

1. VOGE Global APP download

1.1 Apple download:

1.1.1 Scan the QR code above by iPhone camera, when successfully identified, click links to get to store for downloading.

1.1.2 Enter the iPhone App Store to search for "VOGE Global", and download.

1.2 Android download

1.2.1 Open "Google" of Android cell phone itself, then click the button of camera in Search bar, scan by camera, when successfully recognized, it gets to store for downloading automatically.

1.2.2. Scan the QR code above by any scanning tools for the code, it gets to store for downloading automatically.

1.2.3. Get into Play Store of Android cell phone for searching and downloading.



2. Get mapbox token

2.1 Open the browser and search for mapbox, or click Mapbox.

2.2 Enter account information. (See Figure 1)

2.3 Enter payment information. (See Figure 2)

2.4 After successfully registering the account, locate and click on "create a token" to apply for creating a token. (See Figure 3)

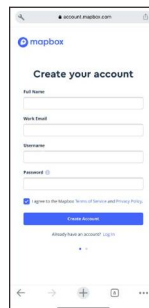

Figure 1

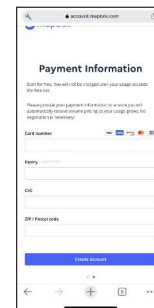

Figure 2

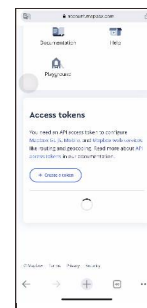

Figure 3

2.5 Enter token name and select applicationscopes, then click on "create token". (See Figure 4)

2.6 Enter the confirmation password to complete token creation. (See Figure 5)

2.7 You can find the token created at the bottom of the page, but it will not appear on the page the next time you log in, so you must be careful to save it. (See Figure 6)

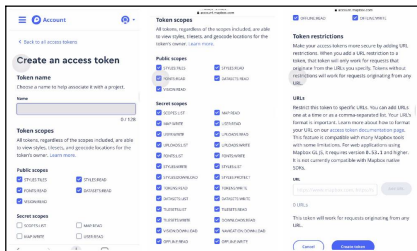

Figure4

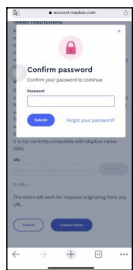

Figure5



Figure6

3.VOGE Global Map configuration

3.1 Open VOGUE Global, then open Setup->Map configuration->Map configuration guidance->Fill blanks for Mapbox Token. (User needs to apply for Mapbox Token and fill blanks, otherwise the navigation doesn't work).

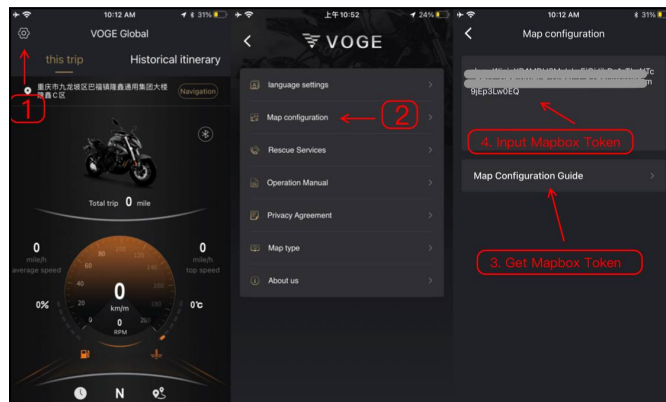

3.2 Mapbox price please refer as below □ The actual cost is based on the price. displayed on the APP

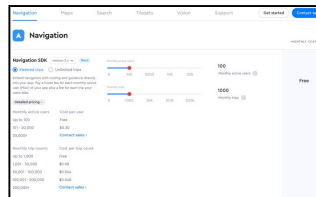

4. Use for basic navigation of Bluetooth(TFT screen)

4.1 Get motorcycle power on, open setup for cell phone->Bluetooth, Select Bluetooth name of (VOGE-) as beginning, when successfully connected, allow to visit phonebook, when connected, the instrument will show the icon of (Bluetooth 1).

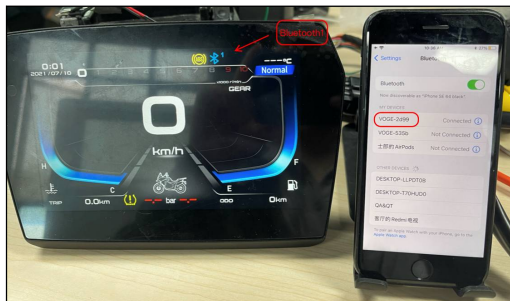
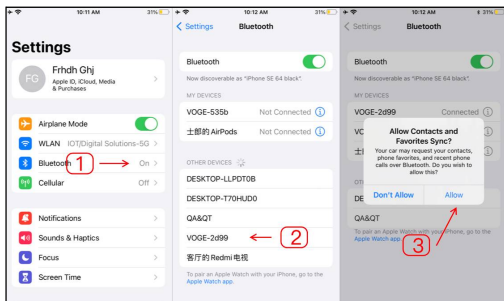

4.2 Open VOG Global APP,Click icon of Bluetooth of (BLE-VOGE-) as beginning for connection, when successfully connected, the icon of Bluetooth will turn yellow, the instrument will show you the icon of Bluetooth 2, at this moment, click down-key on motorcycle's switch to shift to page on instrument of navigation.

4.3 When navigation of VOG Global is working, the instrument will show you corresponding information.

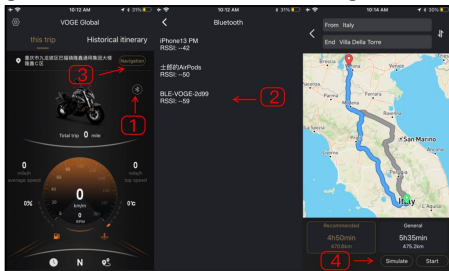

5. The use of driving recorder

5.1 Open the VOGE Global, click [Fuel meter connection] then get into main page of APP, click the icon of camera on the left, get into main page of DVR;

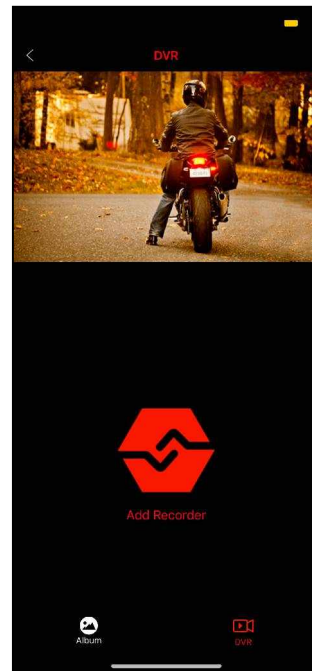
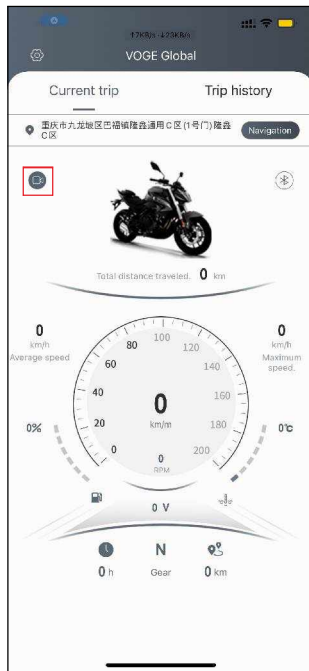
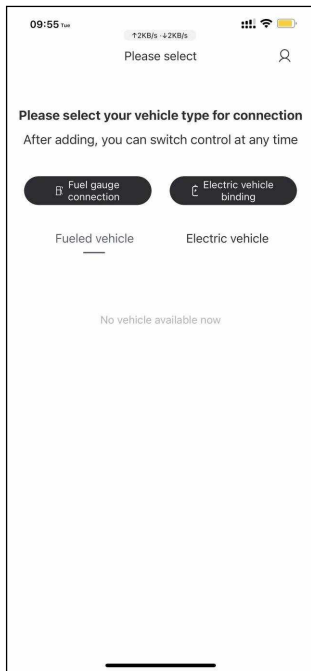

5.2 Click [Add equipment] in main page of DVR, then confirm connection according to reminder, then find out recorder net with beginning of mt in WLAN in setup of mobile phone, then add it in;



5.3 Click [Photobook] in main page of DVR and get into its page, then click [Selection] to select the video or photo needs to be deleted or added in;

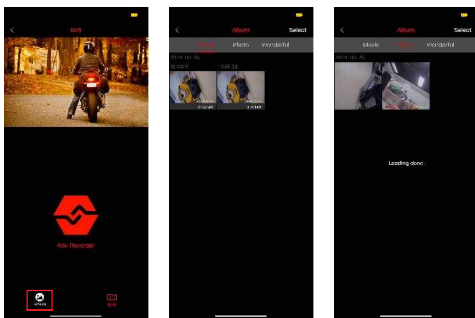

5.4 Click [Recorder] in main page, then shift back to main page of recorder;(See Figure 7)

5.5 When recorder was connected in main page of DVR, click once again the icon for adding equipment to get into page for recording video at real time;(See Figure 8)



Figure7

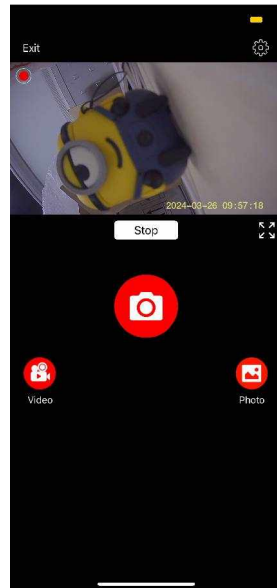
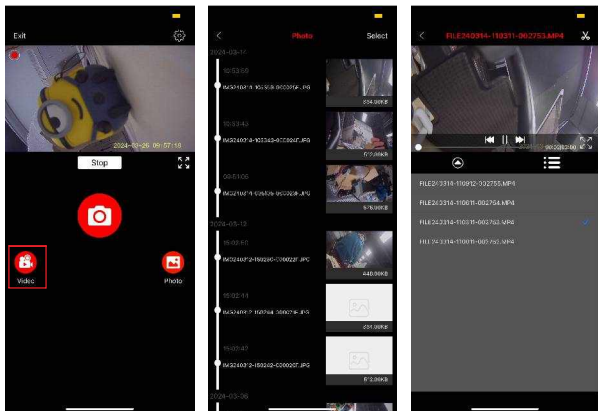

Figure8

5.6 In the page for recording video at real time, click [Recorder Video] to open the list of video, click it to get into video playback;



5.7 In the page for recording video at rear time, click [Recorder photo], it gets into photo list. (See Figure 9)

5.8 In the page for recording video, click the icon in right upper corner to get into setup page for camera parameters, please set up according to your demands. (See Figure 10)

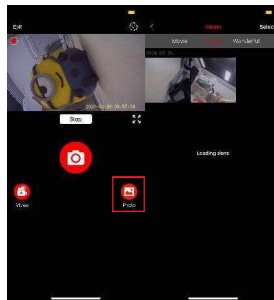

Figure 9

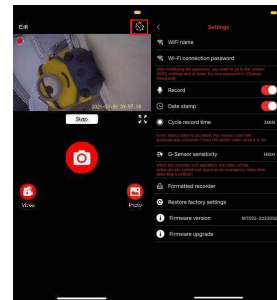

Figure 10

⚠ Caution

- The interface of APP and its function may change with update or upgrade of UI, the final interface and function for using is the same with latest downloaded version of APP.
- On different models, the limit for authority and function may not be same.

Introduction for instrument operation

1.Introduction for buttons

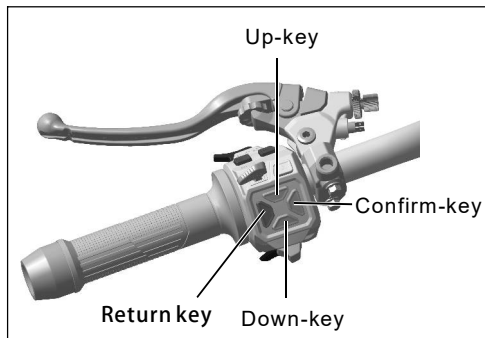

(1). There are 4 driving modes for this model, which are ROAD, RAIN, SPORT, and ENDURO, whose shift are shown as below:

(1.1). When the motorcycle is not in moving, short press mode switch, the modes ROAD, RAIN, and SPORT could be shifted at will.

(1.2). Under any mode of ROAD, RAIN, and SPORT when motorcycle is not in moving, long press mode switch could shift to mode ENDURO;

(1.3).When motorcycle is under mode ENDURO, in case motorcycle is not in moving or when it reset after power off, long press switch could shift to any mode before ENDURO, such as in case shift from ROAD to ENDURO, when the motorcycle reset after power off, the mode recovers to ROAD automatically.

(2).Confirm get into page of setup.

(3). When the Bluetooth is connected, press down key to listen to the call, hang it up by pressing up key, connect to mobile phone first in case Bluetooth is needed, then it works.

(4).Press return key to get back to previous menu or main page.

(5).The 1st menu: Setup, My motorcycle, Quit.

(6).The 2nd menu for setup; Language selection, Metric/Imperial shift, Page shift, Sub total mileage 0 clear, Clock setup, Bluetooth connection, Tire pressure matching-up, and Phone book sync.

(7).The second menu for My motorcycle; Information for My motorcycle, Every version number.

(8).Get into My motorcycle, long press up key, erase all kind of maintenance marks.

(9).Basic Bluetooth navigation; Press down key to shift to basic Bluetooth connection, press Return to get back to main page.



Caution

Short press is 0.5 second, while long press is 2 seconds.

2. Bluetooth connection

(1) Bluetooth name display

Short press down key to get into display page for Bluetooth name, press key return to get back to main page;



(2) Bluetooth connection

Search the Bluetooth name nearby as picture above shows, when connected, the Bluetooth sign on meters lights up, at this moment, the meter can show you the caller ID.



⚠ Caution

Because the compatibility for different Bluetooth versions, so this terminal may not make sure all the mobile phones can connect to Bluetooth.

3. Enter page of setup

Get into My motorcycle

Get into the 1st menu, press key up or down to select My motorcycle, then press key confirm to get into page selection, when the cursor selected page, press key confirm of Next page or Previous page for shifting circulation, when the cursor selected return, press key return to get back to previous page.



Get into My motorcycle

Get into the 1st menu, press key up or down to select My motorcycle, then press key confirm to get into page selection, when the cursor selected page, press key confirm of Next page or Previous page for shifting circulation, when the cursor selected return, press key return to get back to previous page.



Get into setup

Press up or down to select My motorcycle; Press key confirm to get into 2nd menu.



Language selection



When got into 2nd menu, press key Up or Down to select language, press key confirm to get into language selection, press key Up or Down to shift English, Esoanol or Italiano, get cursor on the item you want, then press key confirm to select, then press key return to confirm and get back to 2nd menu.







Metric and Imperial shift

When got into 2nd menu, press key Up or Down to select shift between Metric or Imperial, press key Up or Down to shift Metric or Imperial, get cursor on the item you want, then press key confirm to select, then press key return to confirm and get back to 2nd menu.



<p>0 Clear for mileage sub-total</p>	<p>When got into 2nd menu, press key Up or Down to select 0 clear for mileage sub-total, press key confirm to get into 0 clear for mileage sub-total, get cursor on the item you want, then press key return to get back to previous page, then get cursor on key return and press it to get back to 2nd menu.</p>	
<p>Clock setup</p>	<p>When got into 2nd menu, press key Up or Down to select clock setup, press key Up and Down to shift into tens place for hour, press key confirm to get in, then press key Up and Down to setup its parameters; Press key return to get back to item setup, press key Up and Down to select ones place for hour, press key confirm to get in, then press key Up and Down to setup its parameters; Press key return to get back to item setup; Press key Up and Down to shift into tens place for minute, press key confirm to get in, then press key Up and Down to setup its parameters; Press key return to get back to item setup; Press key Up and Down to select ones place for hour, press key Up and Down to setup its parameters; When setup finished, press key return to get back to 2nd menu.</p>	

<p>Bluetooth connection</p>	<p>When got into 2nd menu, press key Up and Down to select Bluetooth connection, press key Up and Down to get shift on or off, get cursor on the item you want, then press key return once again to get back to 2nd menu.</p>	 <p>The screenshot shows the motorcycle's settings menu. The 'Bluetooth' option is highlighted in orange. The status of Bluetooth is shown as 'ON' with a checkmark icon. Other options visible include Language, Unit, Trip reset, Time, Phonebook sync, Cruise, and Radar. The top of the screen shows '20 km/h' and various status icons. The bottom shows '25°C', '123.0 km', and '20:00'.</p>
<p>Tire pressure matching-up</p>	<p>When got into 2nd menu, press key Up and Down to select “Tire pressure matching-up”, get into Tire pressure matching-up” by pressing key confirm, press key Up and Down to shift between front and rear tire, get cursor on the item you want then press key confirm to match them up, keep air discharging for tire until there is reminder for success, then press key return to get back to 2nd menu</p>	 <p>The screenshot shows the motorcycle's settings menu with 'TPMS' (Tire Pressure Monitoring System) selected. It displays 'Front' and 'Rear' options, both with 'OK' indicators. A motorcycle icon is shown on the right. The bottom of the screen shows '25°C', '123.0 km', and '20:00'.</p>
<p>Phonebook sync</p>	<p>When got into 2nd menu, press key Up and Down to get into “Phone book sync”, press key Confirm to get into “Phone book sync”; Get cursor on the item you want then press key Confirm to confirm downloading, when downloading disappeared, press key Return to get back to 2nd menu, some of mobile phones need this operation to display caller ID/Name</p>	 <p>The screenshot shows the motorcycle's settings menu with 'Phonebook sync' selected. The status is 'Downloading...'. The bottom of the screen shows '25°C', '123.0 km', and '20:00'.</p>

<p>Cruise control setup</p>	<p>When got into 2nd menu, press key Confirm, get in and open the selected item, press key Confirm for selecting, press key Down to off, press key Confirm to select, press key Down to select gear position, when key confirm pressed, press key Up and Down to confirm suitable gear position, press key Confirm, press key Down to select reduce gear the hundred place for rotation speed in reminder, when key Confirm pressed, when pressed key Up and Down to confirm suitable rotation speed, finally press key Confirm. Press key Down to select thousand or hundred place of rotation for reduce gear in reminder, when pressed key to confirm, press key Up and Down to confirm suitable rotation, then press key Confirm. Press key Down to select thousand or hundred place of rotation for upshift in reminder, when key Confirm pressed, press key Up and Down to confirm suitable rotation speed, then press key Confirm, finally press key Return to get back to 2nd menu for cruise control</p>	
<p>Radar setup (Some models equipped)</p>	<p>When got into 2nd menu, press key Up and Down to set up radar, press key Confirm to get into "Radar setup", press key Up and Down to shift on and off, , get cursor on the item you want, then press key Confirm, finally press key Return to get back to the 2nd menu.</p>	
<p>Quit setup page and get back to main page of meter</p>	<p>Press key Return in 2nd menu to get back to 1st menu, then press key Up and Down to select quit, then short press key Confirm to get back to main page, then quit the setup.</p>	
<p>At the place of front and rear tire in page "My motorcycle" of meter, there is display for battery situation of tire pressure sensor, when the power residual in battery was not enough, it will show you information of abnormal.</p>		



Steering set switch

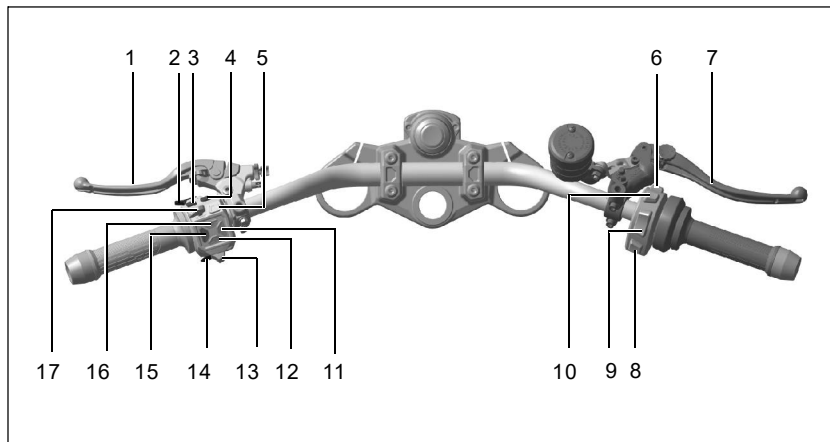

1. Clutch handle
2. High and low beam, overtaking switches
3. Grip heating up button
4. Seat heating up button
5. Emergency light button
6. Driving recorder snapshot button
(Some models equipped with)
7. Front brake handle
8. Front fog light switch
9. Electric start/stop switch
10. Driving mode switch
11. Confirm key
12. Down key
13. Turn signal switch
14. Horn button
15. Return key
16. Up key
17. Cruise control switch





High beam/Overtaking light switch

This model doesn't equip a switch for low beam only, when the motorcycle is power on, the low beam is off, in case push forward or pull backwards the high beam/overtaking switch, or when engine is working, the low beam will be on automatically until engine gets off or voltage is lower than 12.5V.

When pushed forward high beam/overtaking switch to "  ", the high beam gets on, meanwhile the indicator light "  " on meter for high beam also gets on.

When pulled backwards high beam/overtaking switch to "  " the high beam goes off, meanwhile the indicator light "  " on meter for high beam goes off.

When pulled backwards switch to "  ", the high beam gets on, while the corresponding indicator light "  " on meter also gets on, when released, it recovers its original position.

Warning

The headlight could be lighted up when engine is not working, whose power supply depends on battery, so please don't keep headlight on or get it connected for a long time before engine starting.

Caution

When battery voltage is lower than 12.5V, the high and low beam gets off automatically. When battery voltage is lower than 12.5V, the high and low beam could not be on, until engine started or battery voltage recovered above 12.5V.

Turning signal light

When pushed turning signal switch on left switch assembly to left side " ← ", the both front and rear turning signal light on left get on, meanwhile its corresponding indicator light " ← " on meter also gets on.

When pushed turning signal switch on left switch assembly to right side " → ", the both front and rear turning signal light on right get on, meanwhile its corresponding indicator light " → " on meter also gets on.

When press the middle place of turning signal switch on left switch assembly inwards, the turning signal lights go off, while its indicator light on meter also get off.

Emergency light switch " △ "

When pressed down button " △ ", all the turning signal lights and their indicator light on meter were all blinking.

At this moment, in case turned turning signal switch to one side, only the turning signals on this side keep working, and the ones on other side goes off, when pressed down middle place of turning signal switch, both turning signal lights on left and right are blinking (We call it Turning signal function first).

In case need get emergency light off, press once again the button for emergency light.

In case there is emergency stopping or accident on your motorcycle, please press emergency light switch to remind other vehicles on road pay attention to.

Return key " ↶ " on meter

When meter TFT got into menu page, press key " ↶ " to quit menu and setup page.

Key confirm " ENT "

Press key confirm " ENT " to get into setup page.

Cruise control " "

There are speed adjusting key and switch key for cruise control, turn the switch key left to get cruise control function start or stop, when pushed switch forward RES/+, the cruise speeds up by 2km, when pulled backwards " SET/- ", the system sets up initial speed for cruise speed this time according to current driving speed and starts the cruise, long press speed adjusting key could keep speeding up or slowing down.

Clutch lever

Tightly clasp clutch lever, when engine was in gear position, the electric starting could also be done, the gearshift by clutch can be done, meanwhile releasing from cruise control.

Heat up switch " " for grip

This model adjusts heating up level for grip by its adjusting button, whose corresponding display is also on meter. There are 4 levels 0-3-2-1 for this function, 0 means function off, then the heating temperature gets higher by sequence 3-2-1, when the motorcycle got power on, the level for default is 0, every press corresponds to get a level changed, whose sequence is 0- 3-2-1-0-3. Before engine starting, press the heating up button could only be shown on meter but without actual temperature rise, when engine started, the heating-up function really works.

Heat up switch " " for seat

This model adjusts heating up level for seat by its adjusting button, whose corresponding display is also on meter. There are 4 levels 0-3-2-1 for this function, 0 means function off, then the heating temperature gets higher by sequence 3-2-1, when the motorcycle got power on, the level for default is 0, every press corresponds to get a level changed, whose sequence is 0- 3-2-1-0-3. Before engine starting, press the heating up button could only be shown on meter but without actual temperature rise, when engine started, the heating-up function really works.

Front fog light switch " "

When voltage in battery is higher than 12.5V while front position light is on, when turn on the switch for front fog light, the indicator light on meter gets on while front fog light also getting on.



Driving mode switch " MODE"

- (1)When motorcycle is parking, short press mode switch, the modes ROAD, RAIN, and SPORT could be shifted at will.
- (2)When motorcycle is parking, in case under any mode of ROAD, RAIN and SPORT, long press the switch all can be shifted to ENDURO.
- (3)Under ENDURO, when motorcycle is parking or restart after power off, short press the switch could shift to the mode before ENDURO, for example shift front ROAD to ENDURO, when motorcycle got power off then restart, the mode shift to ROAD automatically.

Snapshot button " " for driving recorder

When the Voge Global APP didn't connect, short press the " Snapshot button for driving recorder" on right switch assembly, you can take photo, then the photo will store in card of Micro SD(TF).

Electric starting/Engine kill switch

When turned electric starting/engine kill switch on right switch assembly to position "  ", the electric starting for engine works, when turned electric starting/engine kill switch back to position "  ", the engine is normally working.

When engine is working, in case turn the electric starting/engine kill switch to position "  ", the engine stops working immediately.

Electric starting/Engine kill switch is the fastest while easiest way for stop engine working.

Front brake lever

Tightly clasp this lever, the front wheel brakes, meanwhile rear braking light getting on and cruise speed setting free.

⚠ Danger

In case turned kill switch to position "⊗" during driving may make rear wheel suddenly lock up even accident.

Socket "🔌" for USB power supply

This model equipped power supply socket for USB, according to different Mobile phone's User Agreement, the ones for one-way match up with 18W(5V3A, 9V2A, and 12V1.5A); while the ones for Dual connector is 20W(5V4A) in all.

The water-proof cap for USB power socket is with mark "🔌", take it up then the USB socket could be normally used.

⚠ Warning

The socket plug and connective wire need be prepared by user themselves, when used, well cover in place by water-proof cap to prevent water or dust getting into USB power socket even reduce its working life.

To keep working life of battery, when engine stopped running, please don't use USB power socket of 12V.

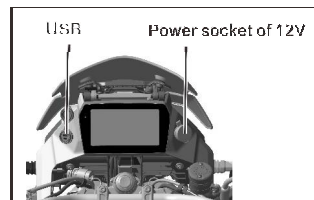

Power socket of 12V,
Power output is ≤60W

ABS system

1. Deceleration and braking under normal situation, release the throttle first, tightly hold the handle bar and then brake. When driving speed fell, to avoid engine stop working, hold clutch lever to get into low gear position.
2. Decelerate before turning, when passing the turning, do everything possible to keep an even speed, in case it is needed, slightly brake, the sudden braking is forbidden.
3. Decelerate in advance in case met the wet road even water on road, take care.
4. Judge the road condition in advance to avoid sudden braking.
5. When the emergency was met, swiftly release the throttle and tightly hold the handle bar and brake by full power.

Caution

1. For the models with function ABS, when braking in full power, there will be obvious bounce back on brake lever or pedal with frequency, which is normal, don't worry about it, only need to do is tightly hold the grips for handle bar.

2. How the ABS works and operates

(1). When ABS/TCS got on: When motorcycle is power on, the self-inspection haven't finished: The ABS can inspect malfunction for wheel speed signal, but it needn't get power source on once again, when the signal for wheel speed recovered, the malfunction could be erased and get back to normal situation; When self-inspection finished: The ABS can take signal malfunction of wheel speed into record, under this case, the motorcycle power source needs be started once again, which means even wheel speed recovered, the motorcycle needs be got power on once again, then the malfunction could be erased and recover to normal situation.

(2). When ABS/TCS is off: Get motorcycle power on, the self-inspection haven't finished: The ABS can take signal malfunction of wheel speed into record, when the wheel signal recovered, the malfunction could be erased and recover to normal situation, when power source of motorcycle needn't be got on once again; When self-inspection finished: The ABS can take malfunction of wheel speed into record, the power supply of motorcycle must be restarted, even wheel speed signal recovered, the power supply of motorcycle still needs be restarted, then the malfunction could be erased and recover to normal situation.

No matter ABS/TCS were on or off, once there is malfunction for wheel speed, it alarms (The indicator light for ABS/TCS gets on)

Danger

In case decelerate from high speed, use the front or rear brake only is dangerous, the motorcycle is easy to skid or get out of control, please use the front and rear brake in a balancing way.

The driving mode shifted to Enduro (Cross country), the ABS will then get off.

TCS traction control system

Confirm sliding difference according to differential device, compare the wheel speed for front and rear wheel. Then confirm stable surplus for rear wheel. In case the sliding difference was exceeded, the control system of engine will adjust torque from engine.

Caution

Some special operation of TCS under some special road conditions:

In case the front wheel gets apart ground under high accelerating speed, the TCS will reduce the torque for engine until front wheel touch ground once again. We suggest turn back throttle lever a little under this kind of situation to get back to stable driving as soon as possible.

On smooth surface, sudden acceleration or full throttle is not allowed which may lead to rear wheel skidding under engine torque, which makes unstable driving, this kind of situation could not be controlled by TCS.

On soft ground such as snow or sand road, the controlling and adjusting ability of TCS largely reduced, even makes rear wheel can turn enough, under this kind of situation, we suggest turn off TCS at this moment.

Except this special road condition, for safety, please always open TCS.

When the driving mode shifted to Enduro (Cross-country), the TCS will then get off.

Quick gearshift system (Some models equipped)

In case the model equipped quick gearshift system, when this function is working, the gearshift could be achieved without operation on clutch lever.

Because the accelerator grip needn't be closed, so the operation for gearshift could be kept without breaking up.

This function could identify if the condition is suitable for it according to position of gearshift spindle, then send a corresponding signal to engine control system. In case the model doesn't equip this function, the clutch lever needs be operated for every gearshift.

Caution

When the motorcycle is power on while gear is in neutral, operate the brake pedal is not allowed;

The quick gearshift could work only when rotation speed of engine is higher than 2000 for each gear position.

Cruise control system

The display area for cruise control only shows you the current speed for cruise.

When the driving speed is higher than 35km/h, while the gear position is between 2 to 6, in case turned on the button for cruise control and it works, the speed for cruise could be kept without operate accelerator.

The buttons for cruise control, in which one is for speed adjustment while another is for function on or off. Get this function on or off by turning switch button for cruise control, short press RES/+, which speed up for cruise by 2km/h, short press SET/- by slowing down cruise speed by 2Km/h, long press the button for speed adjustment can keep speeding up or slowing down cruise speed.

Vehicle speed greater than 35km/h, while gear position is between 2 to 6, get cruise control on, short press "SET/-", the system may set up initial cruise speed this time and start the cruise according to current driving speed.

When cruise control is working, Operating the brake, clutch, and turning off the power will actively deactivate the cruise control function, When the actual driving speed is lower than 35Km/h, the cruise control finished automatically.

The reminder for gearshift up or down, it works according to different engine gear positions and rotation speed:

Gear position	Gear down reminder	Gear up reminder	Gear position	Gear position	Gear down reminder
2 nd	Engine rotation is lower than 3000r/min	Engine rotation is higher than 6000r/min	5 th	Engine rotation is lower than 3000r/min	Engine rotation is higher than 8000r/min
3 rd	Engine rotation is lower than 3000r/min	Engine rotation is higher than 6000r/min	6 th	Engine rotation is lower than 3000r/min	
4 th	Engine rotation is lower than 3000r/min	Engine rotation is higher than 7000r/min			

Danger

To avoid activate cruise control by unexpected way, when needn't use this function, please finish the cruise control function. Be cautious for driving when adjusting driving speed by adjustment button.

The cruise control could not be adopted on crowded road, sharp turning, road with turns or twist, wet road, ice, snow and steep mountain, otherwise it may bring motorcycle out of control even accident.

Driver is the main operator for motorcycle, whose control for motorcycle shall be higher than cruise system. When cruise control is working, any operation for braking, clutch lever or speeding up, the motorcycle will give back control to driver.

The cruise control is only a system of assistance for driving, please don't depend on this function, keep cautious driving from beginning to end.

Radar (Some model equipped)

Open the setup for radar in menu of meter, the function for radar could be used.

When the triangle sign of left back-view mirror of this model got steadily on, which means there is vehicle fast getting close to you or already got close on your left side.

When the triangle sign of right back-view mirror of this model got steadily on, which means there is vehicle fast getting close to you or already got close on your right side.

When turned on the left turning signal light, the triangle sign of left back-view mirror of this model is blinking, which means there is vehicle fast getting close to you or already got close on your left side, shift lane at this moment is very dangerous.

When turned on the right turning signal light, the triangle sign of right back-view mirror of this model is blinking, which means there is vehicle fast getting close to you or already got close on your right side, shift lane at this moment is very dangerous.

In case there is vehicle fast getting close to you behind, the braking light of this model will blink for reminding vehicle behind.

When the yellow sign "🚦" in main page of meter getting steadily on, which means there is malfunction in radar system or it is off.

The design for radar system is for detecting other vehicles on roads with normal width, this kind of detector is limited by technological conditions, under some situations, it may:

1. The related warning may delay;
2. Some warning doesn't work.
3. It may give you warning even blind or near area is without other vehicle.

Some special condition includes but not only:

Bad weathers (Such as rain, snow or thick fog);

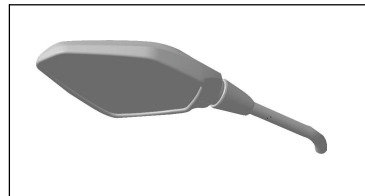

Caution

When the components of radar replaced, it needs be set up once again, how to do this work please contact to local dealer of VOGÉ.

Wrong cleaning up for sensor.

The front side of radar is covered by sticker, paint or other shelters, which all may be bad for radar performance.

The reflection for electromagnetic wave of disturbance or surroundings (Such as turning, special narrow way, turning with changeable radius, tunnel, or obstacle; Too wide the road sunken or rough road surface.

Overtaking from other vehicles with much higher speed than your motorcycle, or overtaking from you against other vehicles with much higher speed than other vehicles, under this kind of situation, the system may not send you any information or signal (Warning);

When the ABS system or torque control system is abnormal.

Caution

The system may fail to recognize materials without any moving (Such as traffic light pole, toll booth or parking vehicles).

In addition, this system may fail to recognize some kinds of motorcycle, bicycle, vehicle or other materials with too high or low ground clearance.

This system could not recognize pedestrian, people on bicycle or pushing it, skateboard or walking people.

Wrong cleaning up for sensor and a period latter, shaking or sudden moving may lead to deviation of radar compared to initial position at delivery from factory.

In case too big the deviation, it is bad to normal working of radar or reduce its performance, such as accident or motorcycle rolling over, replace or disassemble components of radar may also produce deviation against initial position at delivery of factory. Once big deviation is found, please contact local dealer of VOGÉ immediately.

Gearshift device

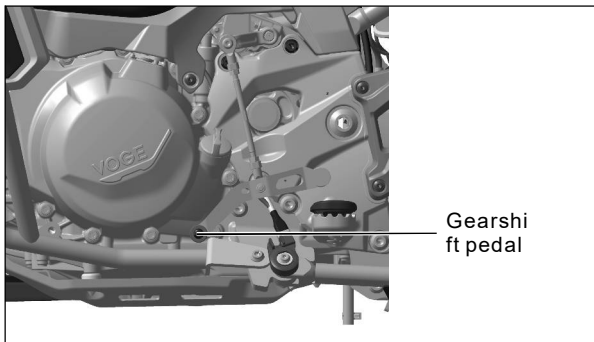

This model equipped gearshift device with 6 gear positions, whose gearshift details are shown as below:

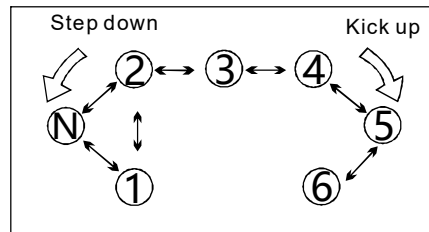

- The gearshift device makes engine stave work within normal rotation speed.
- Gearshift ratio is carefully designed according to engine performance, the driver shall select the most suitable gear position, please don't drive in high speed while in low gear position.
- To ensure smooth gearshift and reduce impact on rear wheel, use clutch in cooperation, before shift to low gear position, reduce driving speed and rise up rotation speed of engine.
- To ensure smooth gearshift and reduce impact on rear wheel, use clutch in cooperation, before shift to high gear position, rise up driving speed and reduce rotation speed of engine.

Warning

Any time, please don't control driving speed in semi-clutch way. Any gear position, sliding while tightly holding clutch is not allowed.

Side stand and main stand

The design for this model includes both side stand and main stand.

Kill switch on side stand is a design for safety, which is a part in starting circuit of engine.

Rear brake pedal

Step down rear brake pedal, the rear wheel brakes, while its indicating light gets on. Meanwhile can finish the cruise control.

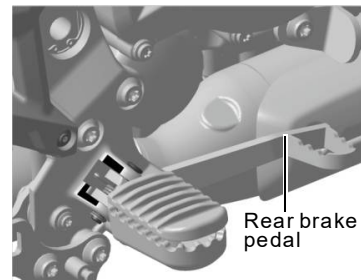
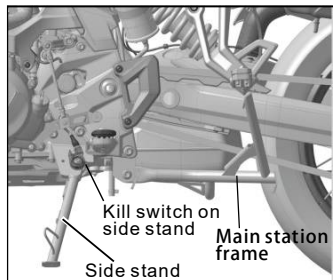

Warning

1. Please park the motorcycle on solid and flat ground, otherwise the parking is not stable.
- 2 In case the motorcycle need be parked on slope, make its head forward to uphill while getting engine into 1st gear position. to avoid turnover due to turning of side stand.
3. The design of side stand takes more consideration for the weight of motorcycle itself, so don't take your body on motorcycle when adopting the side stand to avoid distortion due to overweight.

Caution

1. When the side stand working, it just supports the motorcycle, the engine could be started only when it is in neutral gear; When engine is not in neutral gear, any gear positions the engine could not be started.
2. When side stand completely picked up, tightly hold clutch lever, the engine could be started at any gear position; When the engine is in gear position, once lay down the side stand, then engine stops immediately.

Engine starting

The side stand is laid down.

Press button of ignition switch.

Confirm if the engine is in neutral, the indicator light " N " for neutral gear on meter may get on.

Once conditions above got ready, tightly clasp clutch lever by left hand for ensure safety, the right hand press electric starting button "  ", under this case, you needn't turn the accelerator grip.

When engine started, release electric starting button immediately.

Start engine, to let it pre-heat sufficiently.

Caution

The design for this model is with interlocking switch for ignition circuit and starting circuit, also with kill switch on side stand. The engine could be started under conditions only as below shows:

The engine is in neutral gear " N ", and the ignition switch and kill switch are at position "  ".

The engine is not in neutral gear, and the ignition switch and kill switch are at position "  ", pick up side stand, and tightly clasp clutch lever.

Warning

Enough pre-heating makes better lubrication, to decrease engine abrasion, the colder the weather the more pre-heating minutes are needed. Long time idling working of engine is not allowed, because the poor heat radiation lead to engine overheated and damage the inner parts.

Under cold conditions, suitably turn the throttle grip while pressing the starting button to easier start.

The lubrication works only when the engine is running, so don't push the motorcycle forward for a long way when the engine is stopping. After the engine started, check the flashing or abnormal power on of indicating lights on instrument, in case it is, please top the engine and make corresponding inspection.

Danger

The exhaust gas of motorcycle has carbon monoxide, which is without color, smell, but poisonous. In the place without smooth ventilation or indoors, start engine for idling too long is not allowed, to avoid poisoning.

Fuel filling-up

 **Reminder for low residual fuel level** This alarm light reminds you fuel filling-up

Caution: In case the fuel is not enough, it leads to engine starting failure, or abnormal power output, under this case, keep driving will damage fuel pump.

Don't run out the fuel in the tank, make fuel filling-up before the alarm light gets yellow.

Get mechanical key or spare one into lock's core of fuel tank cap completely, then turn the cap clockwise to lift up. When fuel filled up, get the fuel tank cap to its original position, then powerfully press down to lock it up. Get key back, at this moment, the key could be removed.

Please don't wash the lock's keyhole by water gun with high pressure to prevent water get into fuel tank.

Please use E0 and E5 unleaded gasoline.

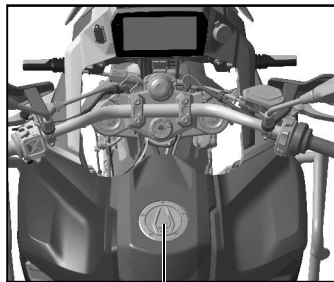

Fuel tank cap

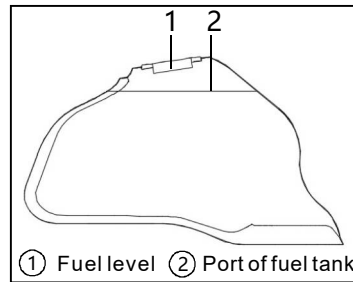

Fuel tank capacity:17L

 **Warning**

- The fuel is corrosive to painting surface, get its color fading and ugly. In case there is fuel on the painting surface, please wipe it up.
- The fuel may expand when it is hot, fully fill up may lead to overflow due to too strong the internal pressure makes fuel tank distort.
- When filling up the fuel, don't make it too full, let the fuel reach the bottom of anti-surge ring on fuel tank's port is enough.

 **Danger**

Please keep far away from fire or heat source when filling up gasoline.

VI. Malfunctions

Too hot the coolant



Alarm light got on means too hot the coolant.

When engine is overheated, keep driving may get engine damaged, so please follow the rules below.

Stop driving and engine immediately, until indicator light goes off. When motorcycle was cooled down, please check coolant and heat radiator.

-In case too low the coolant level, please fill up with coolant.

-In case the alarm light for coolant temperature got on while the electric fan of heat radiator doesn't work, please contact service station nearby for troubleshooting, the best way is contact local dealer of VOGÉ.

Insufficient coolant

In case coolant was not enough or the heat radiator is blocked by stand or stone, we suggest the way as below:

-Reduce loading of motorcycle to reduce heat produced by engine.

-When traffic was met, try everything possible to let engine in idling, please don't turn the accelerator grip to avoid more heat produced.

-In case the operation above still fail to let engine cool down, please stop it, and contact service station for it only nearby as soon as possible for troubleshooting.

Malfunction in engine system



This alarm light on means there is malfunction in engine. Under this case, keep driving may lead to engine ignition failure or fuel supply stopped.

Please stop the engine, turn off the ignition switch, then start once again, in case the alarm light goes off, please keep driving, in case still on, please contact the service station nearby,

Engine starting failure

When engine is in gear position, tightly clasp clutch, if side stand is picked up while fuel is enough.

Is the fuel sufficient.

If the power in battery is enough.

Difficult engine starting

If it is in cold temperature, in case it is, slightly turn the throttle when starting.

Battery power loss.

Too thick the oil; Confirm if the oil need be replaced.

Weak engine power

Check if the element of air filter is clean.

If the motorcycle is at high altitude.

Incorrect check and adjustment may damage your motorcycle and let you fail to find out the malfunction, which can't get the service of Quality Guarantee. In case you don't know much about the correct operation, please contact the VOGÉ dealer.

Malfunction inspection and repair

The content for malfunction inspection and repair in this book can only help you on normal problems, of course they are just basic ones, in case the troubleshooting failed, please contact VOGÉ dealer.

VII. Grinding-in

Grinding-in for new motorcycle

The grinding -in period is important to working life and fuel consumption, so before driving, read the User Manual carefully. (The correct driving within the first 1000km is good for motorcycle performance and bring you fun of driving.

Grinding-in for engine

- No matter the engine is hot or cold, before starting, idly start the engine for enough time, to let oil spread to all positions need lubrication.
 - During this time, the rotation seed of engine in the first 500km should not be over 5000r/min, 50km/h, the second 500km without over 7000/min.
 - During grind-in, the gear position and rotation speed of engine shall change usually, don't let motorcycle work in a same gear position or rotation speed for a long time.
 - During this time, in case the engine works under fixed low speed with light loading, this may lead to bad matching for parts and greater wear-out, so please don't drive under even speed with light loading for long time.
 - During grind-in, except emergency, avoid sudden acceleration or braking as possible.
- No dragging for gear, get into lower gear before deceleration, let engine always works under comfortable situation.
- During this period, don't drive for a long journey, let engine have enough rest.

Grinding-in for tire

- The surface of new tire is smooth, so it is dangerous to driving too fast or at turning. To get the strongest gripping force, the grinding-in is important.
- In the first 200km, you can drive at turning in low speed until all angles of tire tread completely grinded-in.
- The protrusion on tire tread is dangerous, the grinding is a good way for avoid protrusion on tire tread.

Grinding-in for brake system

In the initial 500km, the new brake plate hasn't reached the best friction, to make up for braking loss, you can more powerfully draw the brake lever.

⚠ Danger

To get the best tire grinding-in, in its first 200km, sudden acceleration, turning or braking are not allowed.

VIII. Adjustment

Adjustment for back-view mirror

Adjust the back-view mirror to correct position according to your own stature and driving posture.

The mirror body 1 and case 2 could adjust by hand directly.

⚠ Warning

Sit on the motorcycle and keep it upright, make sure you can clearly see the object in range behind the tail of motorcycle by 10m with width 4.

⚠ Danger

Adjust the back-view mirror during driving may reduce your control on motorcycle, so please don't do this work during driving.

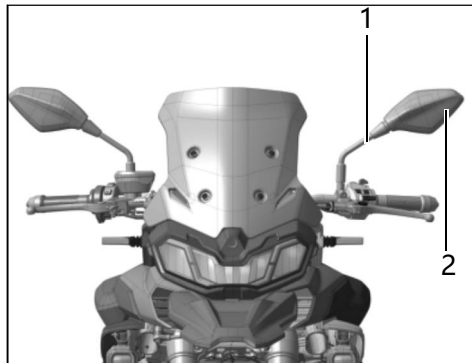

Adjustment for clutch lever

- When engine started, in case need braking or gear shift, tightly hold clutch lever to let friction plates of clutch separate to cut off the power transmission from engine.
- The free play at end of clutch lever shall be within 5-8mm, in case it is incorrect, please adjust as below:
 - Remove the rubber jacket
 - Loosen locking nut 1
 - Turn the adjustor 2, to make free play within 5-8mm.
 - Lock up nut 1
 - Re-assemble the rubber jacket

Warning

Too wide the free play of clutch lever is easy to produce abrasion and malfunction on clutch and gearshift device.

Adjustment for gearshift pedal

- During driving, the road conditions are various, gearshift pedal can change speed and traction force.
- The rod for gearshift pedal is adjustable to suit your driving habit.
 - Loosen 2 pieces of hex. nut 1 for locking up connective rod for gearshift.
 - Turn the connective rod 2 of gearshift, to adjust the gearshift pedal to the position make you comfortable during driving.
 - Finally lock up the hex. nut.

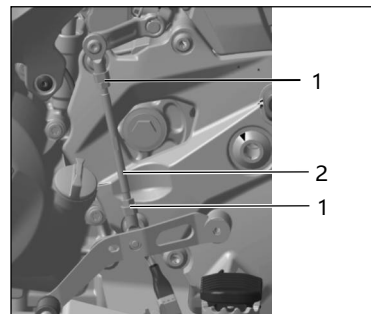
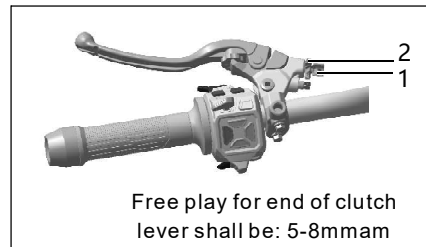

Adjustment for rear brake pedal

- Keep the height of rear brake pedal at a suitable position, in case too high, it is easy to be stepped during driving, which lead to brake pads and plate usually touch makes friction even damage.
- For ensure reliable braking, the free play of rear brake pedal shall be within 15-25mm, in case its free play is incorrect, please adjust as below:
 - Remove split pin 1
 - Remove pin axis 2
 - Loosen nut 3 on adjusting stud
 - Turn connective piece 4 of adjusting stud clockwise or anti-clockwise
 - Turn clockwise the pedal gets up, anticlockwise it gets down.
 - When the height of brake pedal adjusted to suitable position, lock up the nut on adjusting stud.
 - Re-assembly is precisely opposite to disassembly.

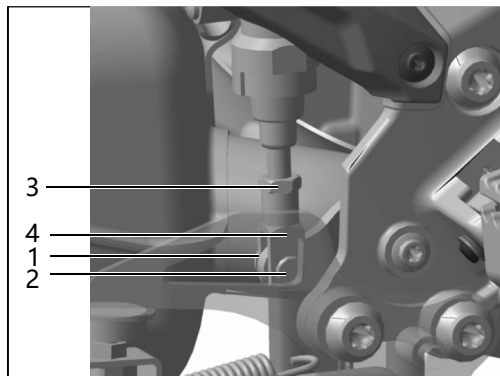

Free play for rear brake pedal shall be 15-25mm
Fastening torque for nut of adjusting stud shall be 18 N.m

Danger

When re-assembling, please replace split pin for a new one.

When re-assembled, repeatedly press and release brake pedal, while confirming you can clearly feel the pressing point.

In case pressing point failed to be felt, please contact VOGÉ dealer.

In case adjustment is not correct, the brake pad and plate are always under stress, which may lead to their damage.

Adjust front shock absorber

Adjust the pre-load and damping load for front shock absorber is to suit different drivers, loadings, driving habits and road conditions.

The pre-pressure of spring is adjustable.

-Turn the adjustor 1 anticlockwise, Spring preload decreases, the pre-loading of spring gets soft.

-Turn the adjustor 1 clockwise, Spring preload increases, the pre-loading of spring gets hard.

The left and right front shock absorbers maintain consistent preload.

Pre loaded factory height 13mm (as shown in the picture)

The damping for recovering of front shock absorber is adjustable.

-Turn the adjustor 2 anticlockwise for left front shock absorber, the damping for bouncing back gets weak.

-Turn the adjustor 2 clockwise for left front shock absorber, the damping for bouncing back gets strong.

- The initial gear of the left front shock absorber adjuster is 8th gear.

The compression damping for front shock absorber is adjustable.

-Turn the adjustor 3 for right front shock absorber anticlockwise, the compression damping gets weak.

-Turn the adjustor 3 for right front shock absorber clockwise, the compression damping gets stronger.

- The initial gear of the right front shock absorber adjuster is 12 gears.

Please adjust the gear according to personal preference.

First gear setting position: Facing the screw plug, turn the regulator clockwise with a torque of 0.5Nm until it can no longer move, then rotate it counterclockwise with a torque of 0.5Nm. The first gear is when you feel the duster sliding into the groove.

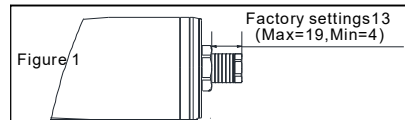
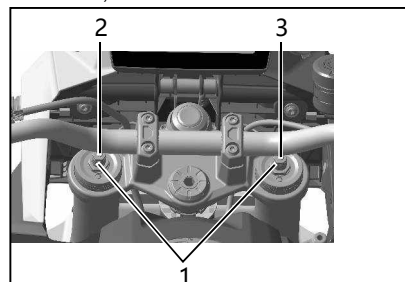

▲ Caution

When turned all the adjustors to their limit could not be powerful, otherwise the adjustors may damage;
When turned all the adjustors to their limit, then return back to gear position, to keep working life for adjustor.
Driving in cold condition, please check if the surface of shock absorber gets frozen before every driving, in case it is, please clean it up by fresh new tissue without dust of dirt.

Adjust rear shock absorber

The pre-pressure for spring is adjustable.

Face to the right side of motorcycle, turn the adjustor 1 anticlockwise, the pre-loading for spring gets soft.

Face to the right side of motorcycle, turn the adjustor 1 anticlockwise, the pre-loading of spring gets hard.

Driving mode of driver only without loading: Turn the djustor 1 anticlockwise to limit, then turn it clockwise by 6 positions (Position of delivery time);

Driver only with 3 cases: Turn the adjustor 1 anticlockwise to limit, then turn it clockwise by 16 ± 1 positions;

Driver and passenger with 3 cases: Turn the adjustor 1 anticlockwise to limit, then turn clockwise by 21 ± 1 positions.

We suggest adjustment to suit different road conditions and driving habits

The setup for 1st gear: Face right front to adjustor, turn the adjustor anticlockwise until stop, then turn it back clockwise, when you feel the clipping ball slides into the groove, which is the 1st gear position.

The returning damp for rear shock absorber is adjustable

Face to the left side of motorcycle, turn the adjustor 2 anticlockwise, the damping of bouncing back. for spring gets weak.

Face to the left side of motorcycle, turn the adjustor 2 clockwise, the damping of bouncing back. for spring gets strong.

Driver only without loading: Turn the adjustor 2 clockwise to limit, then turn it anticlockwise by 18 positions (Position at delivery time);

Driver only with 3 cases: Turn adjustor 2 clockwise to limit, then turn it anticlockwise by 16 ± 1 positions;

Driver and passenger with 3 cases: Turn the adjustor 2 clockwise to limit, then turn it anticlockwise by 14 ± 1 positions.

We suggest adjustment according to different road conditions and driving habits.

The setup for the 1st gear: Face to adjustor right front, turn the adjustor clockwise to limit by torque of 0.5N.m, then turn it oppositely until you feel the clipping ball fall into groove, which means the 1st gear position.

When adjusting the pre-loading of rear shock absorber, please keep main stand working, adjust the pre-loading for rear shock absorber under 0 pressure for rear suspension rack.

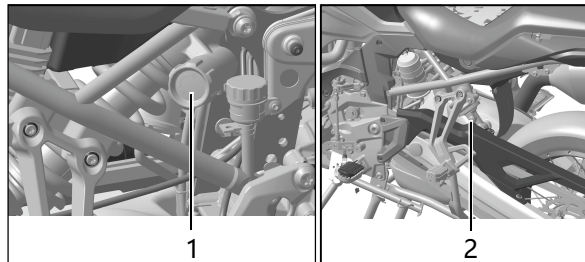

Caution

The adjustment for pre-pressure of spring on shock absorber need tools for it only, the dealer of VOGÉ authorized will provide you good service for this aspect.

Danger

Please don't adjust pre-pressure for rear shock absorber at will, improper adjustment may reduce your control on motorcycle, in case adjustment is needed, please contact dealer of VOGÉ authorized.

Adjustment for headlight dimmer

- All the height of headlight must be correct under any loading of shock absorber.
- To keep safe night driving, adjust the light angle of headlight to suit different loadings.
- The position of the adjustment screw is located below the headlight. First, remove the front upper mudguard and insert it into the light adjustment hole shown in the right picture using a Phillips screwdriver.
- Turn the Phillips screwdriver clockwise to raise the light.
- Turn the Phillips screwdriver counterclockwise to lower the light.

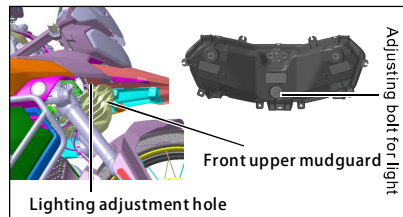

Turning auxiliary light

The turning auxiliary light can get lighting angle wider during night driving, which provides more safety for night driving. The turning auxiliary light works only when low beam is on. When the low beam started, turn on turning signal light switch on one side, the auxiliary light on this side (Front fog lamp) also gets on, turn off the turning switch, the auxiliary light goes off.

Danger

In case you don't know much about the height of light, please contact the VOGÉ dealer.

Adjustment for transmission chain

- Too tight or loose the chain are both incorrect.
- Too loose the chain, it may cause the chain drop during driving then lead to accident.
- Too tight the chain is bad for its working life, meanwhile increase resistance for power transmission.

The correct way for adjust chain is as shown:

In case the tightness of chain fail to meet the demand, the adjustment is necessary.

- Keep motorcycle upright by parking rack.
- Loosen nut 1 for rear wheel axle, adjusting bolt 2 for adjustment, then adjust the bolt according to tightness of chain.
- In case too loose the chain, please turn the bolt2 clockwise.
- In case too tight the chain, turn the bolt2 anticlockwise, then powerfully push the motorcycle forward to get it loose.
- When the chain got the suitable tightness, fine tuning for bolt at left and right, let the scale lines on adjusting piece and rear fork aligned.
- Lock up nut 1 for rear wheel axle on left and right

side for adjustment.

Specification for driving chain:

Specification: 525UX1 Links: 122 pieces

Oil seal Chain Locking ring without opening

Caution

During the loosening and fastening of nut 1 for rear wheel axle, make sure the tight contact between inner side of hexagona head on right end and outer side of chain adjustor whose contact shall be upwards.

61

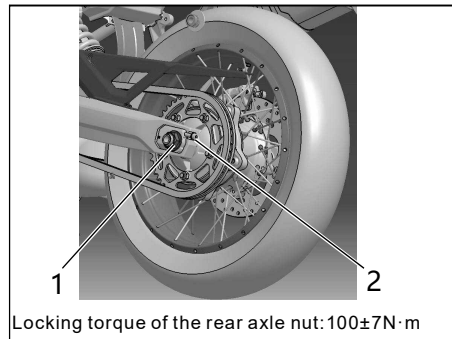
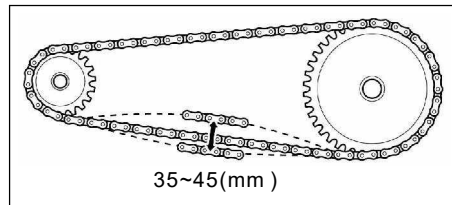

Danger

This kind of driving chain is without opening, the one with opening could not be adopted, otherwise it leads to accident. Replace this kind of driving chain need tools for it only, poor riveting for links without opening will also leads to chain break up even accident.

IX. Check, repair and maintenance

The fuel

The fuel parameter when you purchasing the motorcycle is the most fuel saving way or under a fixed speed, which is quite different to your actual driving, which may be higher than the fuel parameter for reference only.

- The operations below may decrease the fuel consumption under correct driving:

- The driving shall be gentle, stable and without sudden braking as possible, the re-start and acceleration may use more fuel.

- Driving in the city is bad for fuel consumption, the frequent stop and move means frequent start of engine.

- Motorcycle shall drive under economic speed first, whose economic speed is 80km/h, the faster the bigger fuel consumption.

- Avoid driving for short distance. The fuel consumption in the first km after started is double times to normal situation due to the motorcycle hasn't reached the best working temperature.

- In case the air pressure in tire is not enough may increase the rolling resistance of wheel, and then increase the fuel consumption.

- Strictly follow the Period Maintenance table is important to save fuel.

Except the causes above, you may become more skillful with the mileage rise, for more driving fun, you may usually make sudden acceleration or deceleration, at this moment, the fuel consumption uprises compare to your former stable and gentle driving, which actually because of your change of driving style.

The fuel evaporation

When the fuel evaporation system gets failed, please contact the VOGE service station. Refit on fuel evaporation system is not allowed, otherwise the emission may not meet the standard. After removal and repair, check the connection of tube joint, leakage of pipeline, or block; Check the squeeze, crack or damage on rubber hose. The fuel vapor was released into carbon canister though the desorption tube, when the engine stopped, the activated carbon in the canister absorb the fuel vapor; When the engine is working, the fuel vapor in the carbon canister releases into combustion chamber through desorption tube join the combustion, which prevent the fuel vapor get into air directly to be pollution.

The absorbing tube also make the air pressure in fuel tank get balanced, when the air pressure in fuel tank was lower than air outside, supplement the air pressure through the absorbing tube on carbon canister; In this case, please make sure all the tube smooth without blocking and squeeze, make sure the correct installation of anti-toppling valve, otherwise the fuel pump may damage or fuel tank may get distortion even damage other parts.

The fuel evaporation control system works as below:

- (1)When the gasoline in fuel tank gets heated, the gas vapor get out, absorbed after get though the end TANK of carbon canister of dumping valve.
- (2)When the motorcycle inclined over 60° , the dumping valve gets closed, the gasoline failed to flow into carbon canister through dumping valve.
- (3)The fresh air flow from end A of carbon cannister to the end PURGE to bring the gas vapor into throttle valve, then join combustion by getting though the air inlet tube.

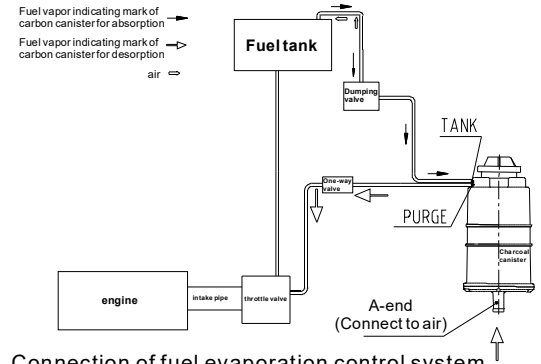

Connection of fuel evaporation control system

Tool kit

Tool kit is in a bag under driver seat, remove the driver seat, at its bottom, the tool bag could be seen (Which including tool bag, double usage screwdriver, screwdriver lever, solid wrench of 14-17, solid wrench of 8-10, Socket hex. spline wrench of T25, Socket hex. spline wrench of T30). In case driving under bad conditions, after that, rain or washing, please make lubrication for corresponding position.

Moving parts and their maintenance

For safe driving, keep the good lubrication for moving parts is a necessary work for getting its working life longer.

-Clutch lever's shaft

-Brake lever's shaft

-Bearing for brake pedal

-Shaft for side stand and spring hook for side stand.

-Shaft for main footrest, pillion step, and returning spring.

battery

Maintenance for battery

The battery on this model is completely free of maintenance which needn't check the electrolyte level and its ratio, but need to check the power charging periodically.

Caution

Except the chain needs lubricant for it only, other lubrication point we suggest adopt lubricant of lithium.

Warning

For keep battery working life, additional electrical device with strong power is not allowed, in case add electrical device with weak power, please contact service station of VOGÉ, make sure the added electrical device use the reserved joint on original motorcycle.

Caution

In case it is possible, charge the new battery by 30 minutes for the first time, which could effectively make working life longer.

The power charge for battery

In case the ignition lock is off, while the voltage of battery is lower than 12.6V, we suggest charge the battery.

- Charge the battery by stable DC power source or use the suitable power charger and strictly follow its instruction.
- The DC charging voltage shall be DC (14.5±0.3)V with stable current no more than 1A;
- The charging hours is 6 to 8, don't let the current than the maximum limit.
- The overcharging may shorten the batter working life, so don't adopt this way.
- Cut off the power circuit with motorcycle before charging.
- Usually check the cleanliness of terminal or wire joint, in case already corroded or oxidized, please clean it up.
- In case the motorcycle is usually in driving, the motorcycle may charge the battery automatically. In case just a few times or driving for short time, the power in battery may not be enough. The battery may discharge by itself, whose speed depends on the battery specification or surrounding temperature. When the surrounding temperature gets rise, the discharge speeds up, for example, the discharge speeds up by 100% with each temperature rise by 15°C.
- In case the battery is without suitable charge in cold weather, the electrolyte may get frozen, then makes the battery damage or terminal distort, make the battery full of power can let it stronger in low temperature.
- Parking for a long time without driving need to cut off the negative terminal of battery first, otherwise the electrical parts on the circuit may gradually make power run out.
- Parking without driving more than 1 month need to charge the battery monthly. In case the battery is without charging for a long time may lead to natural failure.
- Correctly dispose the abandoned battery or electrolyte, don't let it be the pollution to the environment.

Danger

The battery may produce hydrogen, so keep it far way to heat source of park.

Wipe up by dry cloth may produce spark of static electricity, to avoid this, please adopt wet one.

Disassemble and re-assemble battery

Before disassembling or re-assembling battery, please turn off ignition switch first, then get the motorcycle power off.

When disassembling battery, remove negative terminal first, then the positive one. When re-assembling battery, assemble positive terminal first, then the negative one. When disassembling battery, before taking it out, turn the bolt onto battery first, to avoid nut dropping off during removal of battery.

When battery connected once again, the data storage for tire pressure will erase, when the driving speed is above 25km/h, the tire pressure updated automatically; Then please connect to APP for driving recorder once again to keep same time with it; Then get into menu for setting up on meter to adjust the time of meter.

External power supply

- When the power in battery fail to start engine, the outer power source could be adopted for engine starting.
- When the outer power source is adopted, use the wire clip for spring only of completely insulated to avoid short cut or non-jump spark between guiding wires. The battery A is the power source on motorcycle while the battery B is an outer one. The positive terminal 1 on outer power source B connect to positive terminal 2 on power source A on motorcycle, while the negative terminal 3 connect to the metallic part C on engine to connect the ground. Start the engine, in case failed, wait for minutes and then start once again to protect the engine and battery. Before removing the guiding wire of outer power source, let engine run for minutes, then cut off the negative wire and ground wire first, then the positive wire.

Warning

Don't put the battery up side down, otherwise the electrolyte may flow out from the breathing hole.

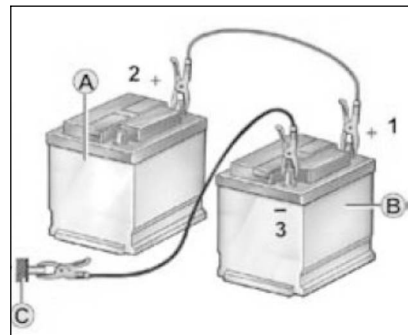

Maintenance for air filter

- The air filter locates under fuel tank, if it is blocked by dust, the air inlet may get harder, which reduce power output and increase fuel consumption.
- In case driving under dusty condition, clean up and replace the element more frequent.
- The cleaning up and replacement for air filter element:
 - Remove covering parts above air filter;
 - Press the clipping piece for element of air filter inwards, then lift up bracket for element of air filter;
 - Remove the old element of air filter backwards, then clean it up or replace;
 - Replace the element for a new one, get the round hole on upper and lower side aligned to positioning pillar, make sure it well stick to bracket;
 - Press the bracket downwards into case body of air filter, the locking position for clipping piece of installing element is suitable, lift up bracket slightly without loose or dropping off;
 - Recover the motorcycle in place.
- The broken element may let dust get into engine and make engine damage, so please replace the broken one.
- In case the element is installed in wrong position, the dust may bypass the element and get into engine then get engine damaged, so please install it in place.

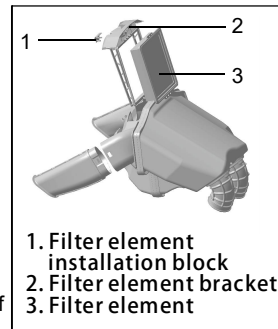

Caution

When cleaning up the element, the blowing air shall inlet from the side of metallic net, in case get in from another side, the dust may stay in the clearance of element, which largely reduce the effect of cleaning up.

Oil in engine

Check the oil level

- The oil inspection window and filling up port are both at the right cover of engine.
- The checking for oil level:
 - Put the motorcycle on horizontal ground and get main stand opened.
 - Start engine and make it idly run until cooling fan begin working, then idly run for 1 minute.
 - Stop engine and wait for a minute to make sure oil returned.
 - Clean up surrounding of oil filling-up port.
 - Turn and remove oil gauge and wipe it up by industrial tissue, then insert the oil gauge in and turn by 1 round, then remove it to check oil level.
 - The correct level shall be within the upper and lower scale lines of oil gauge 1.
- In case the oil level is higher than upper line, outlet some oil.
- In case the oil level is lower than the lower line, inlet some oil.
- No matter inlet or outlet, check the oil level once again when the operation finished.

The maintenance for oil in engine

The oil can make sure the effective lubrication for parts in the engine, besides more, the oil helps cooling down the engine, in addition, the oil is also good for sealing the engine, so the maintenance of oil is very important.

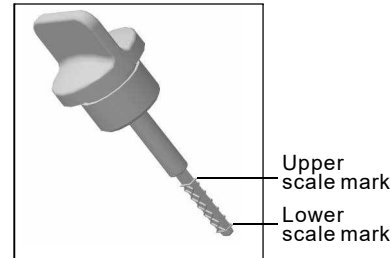
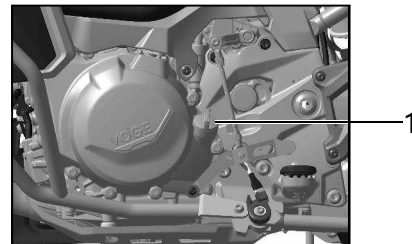

•Outlet the oil:

–In case too high the oil level, please remove the oil drainage bolt by socket wrench, the oil drainage bolt is at the middle place of engine bottom (Picture 1).

–After releasing an appropriate amount of engine oil, please reset and lock the engine oil bolts.

–Outlet some oil then re-assemble the oil drainage bolt. Too high or low the oil level may both damage the engine.

Please make sure the oil is at a correct level.

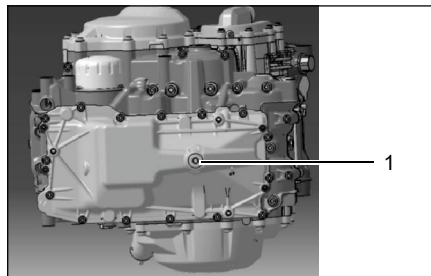

Caution

The oil may expand with temperature rise, so its level also changes.

The hotter the engine the higher the oil level, while the colder engine with lower oil level, which both are normal.

Keep the motorcycle upright when checking the oil level, in another word is vertical to the ground.

The only correct way for confirming oil level is through the immersing position on oil gauge.

Danger

The oil drainage bolt is near the muffler, please drain the oil off when the bolt and muffler basically cooled down, when draining the oil, protect yourself from hot oil to avoid scald.

Replacement for engine oil

- Replace the engine oil when maintenance period reached.
- Replace the oil when engine is hot to totally drain off the old oil.
- The replacement for oil:

Start engine.

Stop engine. Screw off the oil gauge, remove oil drainage bolt and washer on oil bottom case, then drain the oil off. When oil stopped flowing out, remove oil drainage bolt on oil collection tray. When oil completely drained off, assemble oil collection tray and oil drainage bolt for oil bottom case, then replace the washer.

-Fasten the oil drainage bolt on oil collection tray to given torque (Torque: 10N.m)

-Fasten the oil drainage bolt for oil bottom case to given torque (Torque: 25N.m).

-Fill up crankcase with appointed oil.

-Oil capacity:

-Fill up with fresh oil from its inlet port with capacity of 3000mL (In case the secondary oil filter needn't be replaced, its capacity is 2800mL, in case the crankcase needs be opened for complete maintenance, under this case the oil capacity shall be 3200mL).

-When filling-up finished, check the oil level. Make sure there is not any oil leak.

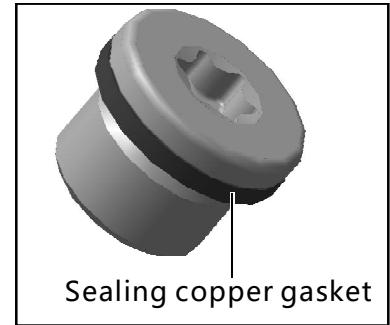

Warning

Replace the oil drainage bolt and its seal ring for a new one when re-assembling, in case still use the old one, it is easy to make oil leakage.

Danger

Drain off the oil when the engine is hot makes total drainage, but the hot oil and muffler may get user hurt, so before the drainage, wait for the bolt and muffler basically cooled down.

Oil filling up for engine

- Confirm the oil element already replaced and its cover already assembled.
- Confirm the oil drainage bolt and gasket are both replaced and re-assembled.
- Add new engine oil from the oil filling port, The capacity for oil filling-up is 3000mL (In case the secondary oil filter needn't be replaced, the capacity for filling-up is 2800mL, in case break up the crankcase for a total maintenance, the capacity shall be 3200mL)
- Inject oil according to P68 Check the oil level before and after operation.

Caution

Replace the oil when engine is warm.

Specification of oil: Oil above 5W/40-SN or above Capacity for oil filling-up: 3.0L.

Dispose the replaced old oil and element in environment friendly way.

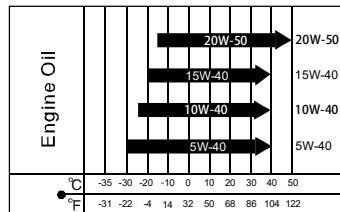

If you need to use them in winter, please exchange 5W-40 or 0W-40 low temperature resistant oil and you need to exchange 10W-40 or 20W-50 oil again in Summer.

Warning

Wrong oil specification or bad oil may damage the engine, EFI system and shorten the working life of spark plug and catalyst in muffler, don't use them.

Replacement of oil filter

- When each Maintenance period was reached, please replace the oil element for engine.
- Replace the oil element when the oil in engine was drained off.
Get main stand holding the motorcycle.
- Drain off the oil.
- Remove oil filter by special tools. (Tool: Cap-shaped wrench for oil filter).
- Confirm the fastening torque for tube joint of secondary oil filter is: 28N.m, coat threaded part for new secondary oil filter and o-ring with fresh oil.
- Assemble secondary oil filter and fasten it to given torque: 11N.m.
- Assemble oil drainage bolt and copper washer.
- Fill up with oil of given specification.

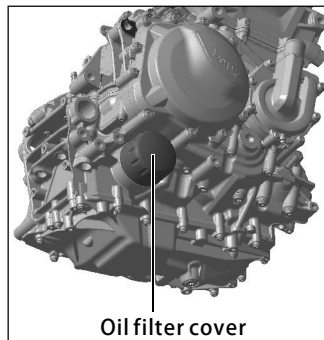

Oil filter cover

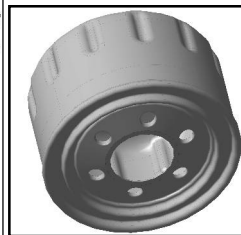

oil filter

Warning

Check the gasket on cover of oil element, replace for a new one if it is necessary. A wrong oil element may damage the engine, please surely adopt the origin VOGÉ parts.

Coolant

Check and maintenance for coolant

The coolant can radiate the heat for hot parts in engine and keep its normal " working temperature" .

- The check and filling-up of coolant are all done in sub tank.
- Stop the engine.
- Check when the engine is cold , because the coolant may expand when it got hot.
- Keep the motorcycle upright.
- Check the coolant level through expansion tank, whose level shall be between the scale line LOWER and UPPER.
- In case the coolant level is under scale mark LOWER, fill up from the port of expansion tank.
- In case the coolant level is higher than scale mark UPPER, the coolant may overflow from tube when it got hot and expand in working, for avoid hurting by hot coolant, fill up too much is not allowed.
- In case the motorcycle need fill up the coolant frequently, which means there is malfunction in the cooling system, under this case, please contact the VOGÉ dealer.

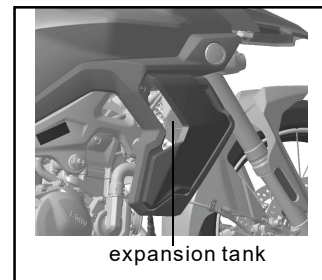
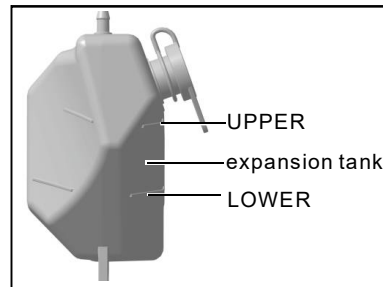

Warning

When the expansion tank is totally dried up, don't fill up coolant by yourself, because under this case, the air may already get into the cooling system and need to be exhausted, so please contact the VOGÉ dealer for maintenance.

The replacement for coolant

•The coolant drainage:

- Keep the motorcycle upright by standing rack.
- Lay a liquid tray under the engine.
- Remove the water drainage bolt, because all the heat radiation system is connected, so all the coolant may flow out from this port.
- After the old coolant is completely drained, replace the flat gasket and install the drainage bolt back.

•The coolant filling-up:

- The coolant need be filled up from the heat radiator and expansion tank the two positions:
- Open the tank cap of heat radiator and fill up with the coolant

Check the full filling-up of coolant from the tank cap of heat radiator, pinch the water tube when filling up to exhaust until it is full, then well cover the tank cap.

–After the tank's cap of heat radiator covered, start and run the engine for 30 seconds to make the coolant fully reach every position need it.

–Make the engine stop, after the engine cooled down, open once again the tank's cap of heat radiator, check if the coolant already was full, in case the level fell down, please fill up once again until it is full, then well cover the tank's cover of heat radiator, repeat this action until it gets full, in case it is necessary, it may need to repeat two times or more.

–Finally, remove the black rubber cover of the expansion tank and add coolant to the specified upper and lower markings.

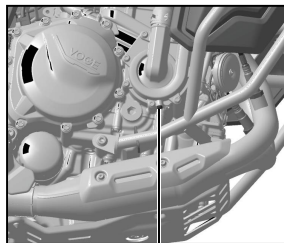

Drainage bolt

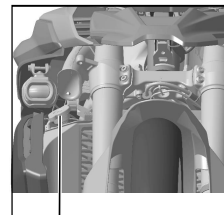

Radiator tank cover

Warning

Fill up with running water is not allowed, otherwise it may damage the cooling system, the mixture among coolant of different brand of specification is not allowed.

•In case the air temperature is lower than the one marked up on the label, please adopt the coolant fits for lower temperature.

•The VOGE coolant is with ice point of -45°C of glycol so we suggest purchase or replace by Made in VOGE.

 **Caution**

•To keep the coolant performance, replace each two years.

Coolant specification: ice point of -45°C of glycol

The filling-up volume: 2L

Dispose the replaced old coolant in environment friendly way.

 **Danger**

When filling up the coolant, in case open the tank's cap of heat radiator after engine started, please let the engine cool down first, otherwise the hot coolant may inject out and make you hurt when you opening the cap of heat radiator.

Brake liquid

The brake liquid is an important part in hydraulic system for power transmission, so it need be reliable under high, low temperature or flowing performance at low temperature and good in anti-corrosive, so please adopt the correct one.

Check the brake liquid

- Too low the liquid level in brake oil cup may let air get into brake system to reduce the braking performance. So please periodically check the liquid level.
- Check and fill up the brake liquid shall conduct at the front and rear oil cup.
- The liquid level shall not be higher than mark (UPPER or MAX), when it lower than mark (LOWER or MIN), please fill up immediately.
- The brake liquid is corrosive, which is bad for the surface of plastic or paint.

Warning

In case the filling-up of brake liquid is needed, open the cap of oil cup by yourself may let air and moisture in, which largely reduce the braking performance even failure, so please contact VOGÉ dealer to do this work.

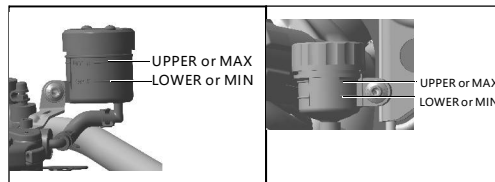

The specification of brake liquid

- When there is impurity or moisture in the brake liquid, please filter or replace, otherwise it may reduce the pressure for braking and make bad braking performance, especially in wet weather or place.
- The brake liquid works more than 2 years, it may get bad due to the long work, please replace immediately.

The specification for brake liquid is DOT4.

Please dispose the replaced old liquid in environment friendly way.

Caution

Mixture of brake liquid among different brand and specification is not allowed due to the different formula of different brake liquid may let the braking performance fall down.

Driving chain

The driving chain for this model is the one with oil seal, the place of chain's pin has a special oil seal for sealing lubricant, this chain is the one without opening, so in case replacement is needed, please contact VOGÉ dealer.

Before driving every time, please check and confirm problems below:

- Flexible pin of chain – Roller damaged –Rusty or corrosive plate of chain.
- Jamming in turning of chain links.
- Any problems above were found, please contact VOGÉ dealer.

Wear-out on chain may also lead to abrasion on sprocket wheel, please confirm problems below:

- Wear-out on sprocket wheel - Damage or crack on tooth of sprocket wheel.
- Any problems above were found, please contact VOGÉ dealer.

Maintenance for driving chain

Dirt or dust on chain is bad for its working life, please clean it up and lubricate periodically, because there is o-ring and lubricant at place of chain's pin, so incorrect washing and lubrication may damage rubber o-ring and lubricant, which decrease chain's working life.

- Wash driving chain by steel brush is not allowed.
- When washed up, wipe up water or neutral cleanser immediately, then dry the chain up in air for preparing to lubricate.
- The chain with oil seal needs the oil for it only, evenly coat the inner and outer plate of chain with oil, when finished, wipe up the surplus oil.
- Some lubricant for chain have solvent or additive may damage seal ring of chain, so please adopt the one for this kind of chain only.



Caution

When replacing driving chain, please check the abrasion on driving and driven sprocket wheel, replace sprocket wheel at same time in case it is necessary. In case there is not any oil for chain with oil seal, please adopt gear oil of SAE90 as substitution.



Warning

Please wash up chain by water or neutral cleanser. Adopt solvent with volatility such as painting thinner or gasoline is not allowed. Adopt washer with high pressure for chain washing is not allowed.

Tire

The tire connects the motorcycle and ground, it is very important, the incorrect specification and status is very bad for motorcycle performance.

The tire pressure in tire

- The wrong tire pressure makes its working life shorter.
- Too low the tire pressure makes difficult turning, and speed up the tire wear-out.
- Too high the tire pressure decreases the contact area between tire and ground, which is easy to skid and out of control.
- When driving in high speed, the centrifugal force may open the air valve core on the tire, to avoid the sudden air leakage, we equip it a rubber with metallic liner, cap and connect with air valve core by thread.
- The pressure of tire's air charging rises with tire temperature, so adjust the tire charging pressure when it is cold and its temperature almost the same with surroundings.

Check the limit of tire wear-out

- The tire surface is with the mark of wear-out.
- In case the tire tread already reached the mark, which means the tire could not be used any more.
- The wear-out mark is near the TWI mark at tire edge, the wear-out mark is in the water drainage groove on tire tread, which is a protrusion, when the protrusion is worn out, means the tire already worn out and need to be replaced.
- The worn out tire may get penetrated and bring motorcycle out of control.
- When the depth of tire tread reached the minimum limit, its performance and gripping force may largely fall down.

Danger

The incorrect tire pressure is not only bad for performance, but also lead to accident. Overloading may lead to tire failure and bring motorcycle out of control.
Make monthly inspection on tire pressure

Under normal temperature, please check the tire pressure as table below.

	Driver only	With passenger
Front wheel	220KPa	250KPa
Rear wheel	250KPa	290KPa

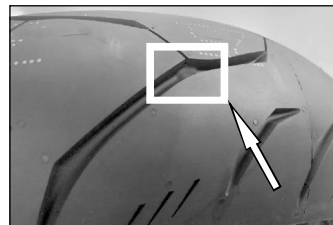

The repair for tire

- Repair the small hole on tubeless tire, please remove the tire first, patch up inside of tire without outside, because the high speed driving may lead the outside patch outside flexible under centrifugal force.
- Within 24 hours after patched up, the max speed shall not be higher than 80km/h.
- In case the side of tire get broken while the breaking size is bigger than 6mm, the tire could not be used any more.
- In case many damages such as damage, scratch or wear-out were found on the tire, the tire need be replaced.

The replacement for tire

- When replacing the tire, two tires on one motorcycle with different brand, specification, tire tread or 1 new while another is old are all not allowed.
- After the tire replaced, the motorcycle needs to make dynamic balance and alignment, in case the dynamic balance is poor, the operation performance of motorcycle may fall down, also makes uneven wear-out on tire.
- The rolling direction of tire has the mark arrow, turn the tire along this direction only, which make sure water & skidding proof, improve gripping force, reduce noise and make working life longer, get the tire performance better.
- The tires with given specification are all strictly tested, who meet the demands of most road conditions, while the ones without test can't make sure the safety and suitability.
- Seal the contact position between the wheel rim and tire lip of tubeless tire.
- To avoid air leakage, the tubeless tire needs special tool and machine for disassembly and re-assembly.
- The tire replacement need be done by VOGÉ dealer, they are skillful and with necessary tools or machine.

Fuse box

The fuse of this model includes 1 major fuse, 9 fuse branch and 4 for spare parts (As picture on the right shows).

- Fuse for power charger(10A)
- Fuse for control signal(25A), braking light, BCM, meters, kill switch, horn, and power supply for USB.
- Fuse for power supply of motor of ABS (25A): Power supply for motor of ABS system.
- Fuse for power supply of solenoid valve of ABS system (10A): Power supply for solenoid valve of ABS.
- Fuse for power supply of ignition switch (25A): EFI system, BCM control, DC socket, power supply for USB, lighting system and spotlights.
- Fuse for main relay of EFI (15A): Power supply for ECU control and electric fan, power supply for ignition coil and oil injector.
- Fuse for power supply of fuel pump (10A): Power supply for fuel pump.
- Fuse for electric fan (10A): Power supply for heat radiation fan of engine.
- Fuse for BCM (15A): Power supply for BCM and lighting.
- Main fuse (40A): Power supply for all circuits on motorcycle except starting motor.

main fuse

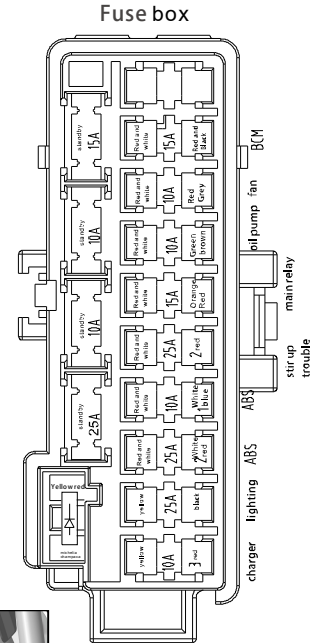
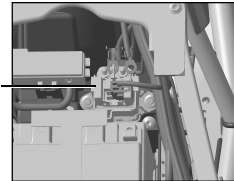

•When the fuse chip was checked or replaced, please well cover the cap of fuse box to avoid water getting in in rainy day or after motorcycle washed, which is easy to lead to electrical malfunctions.

⚠ Caution

In case the fuse chip usually burns out in short time, which indicates there is malfunction in electrical system, please contact the VOGEL dealer immediately.

⚠ Danger

- Please use the fuse chip with given specification, substitution such as aluminum sheet or iron wire are not allowed.
- Connect the fuse chip out of our suggestion is not allowed, otherwise it is very bad for circuit even catch fire or burn out the motorcycle.

Relay

This model has 6 relays (As picture on the right shows).

- Relay for EFI
- Relay for fuel pump
- Relay for electric fan
- Relay for electric assistant starting
- Relay for ignition switch
- Relay for kill switch

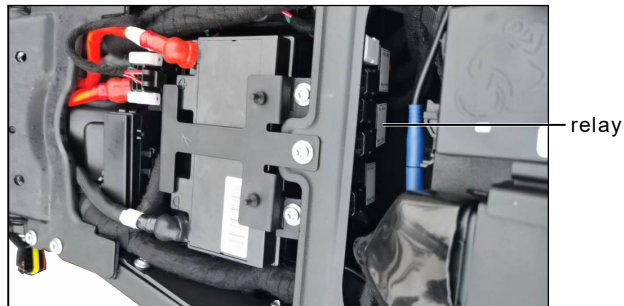

Brake pad

The abrasion of brake pad passed the min. thickness limit may lead to poor braking performance, under some cases, it may lead to brake system damage. For the reliability for braking, the abrasion passed Min. thickness limit is not allowed.

Replacement for brake pad

The correct replacement needs to remove the wheels, so this work shall be done by VOGÉ dealer.

No matter the front or rear brake pads, replace them in pairs as a set, in case only replace one piece of them, it may make imbalance brake even accident.

After the brake pads removed, don't operate the brake lever or pedal, otherwise the brake piston may return hardly, meanwhile making leakage of brake liquid.

- The oil or other dirt touches brake pad and plate when replacing is not allowed, in case if there is, please clean it up, otherwise it may make poor braking performance.

Wear-out limit for front brake pad:

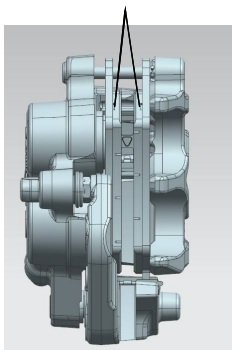

Wear-out limit for rear brake pad:

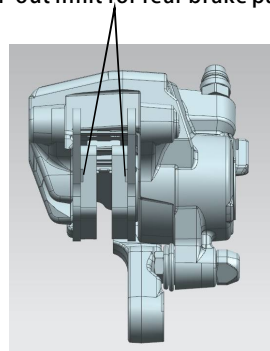

Danger

When replaced for new pads, please repeatedly confirm the brake lever and pedal, confirm the pads tightly press the brake plate, meanwhile confirm the free travel of brake lever and pedal

Replacement for lighting signal

•If there is no light signal, you may be in danger, because the light helps others easily pay attention to you and your motorcycle.

Please replace the broken lights.

The headlight, front position light, turning signal light, rear position light, brake light and registration plate light are all LED and sealed, in case broken, go to the service station for replacement. The replacement for lights please follow the description and specification below.

The dirt especially the grease on light's surface may be bad for heat radiation, which lead to light overheat even reduce its working life.

Parameters for electrical system	
Battery specification	12V 12Ah
Headlight (High/Low beam)	12V 7.4W/17.5W
Front position light	12V 3.9W
Rear position light	12V 0.12W
Rear brake light	12V 1.98W
Front turning signal light	12V 2W
Rear turning signal light	12V 2W
Rear registration plate light	12V 0.3W
Front position light	12V 8.5W
Fuse chip specification	40A, 25A, 15A, 10A

Warning

When a signal light is broken, replace for a new one with completely same rating power and specification, otherwise the different one may lead to electrical circuit overload or light broken very early.

Maintenance plan

The table below shows you the inspection for each periodic maintenance, whose interval of time and mileage, set whom reached first as standard, and make the inspection as table below every time.

		Periodic Maintenance table									
Items		Interval	km×1000								
			1	5	10	15	20	25	30	35	
Power transmission system	Lubricant		R	I	R	I	R	I	R	I	
	Lubrication element		R	\	R	\	R	\	R	\	
	Check lubricant level		I	I	I	I	I	I	I	I	
	Check seal performance for fuel tube		I	I	I	I	I	I	I	I	
	Check the fuel pump element		\	\	I	\	I	\	I	\	
	Throttle valve body/Carburetor		\	C	C	C	C	C	C	C	
	Check coolant level		I	I	I	I	I	I	I	I	
	Coolant	2 years	\	\	\	\	\	\	R	\	
	Check seal performance of air inlet system		I	I	I	I	I	I	I	I	
	Valve clearance		Check every 20000km								
	Spark plug clearance		\	I	I	I	R	I	I	I	
	Air filter element		I	C	C	C	R	C	C	C	
	Clutch operation system		\	A	A	A	R	A	A	A	
	Lubrication system	Check lubrication and tightness for steering bearing		I	I	L	I	L	I	L	I
Check lubrication for Fr. & Rr. Wheel and sprocket base bearing			\	L	L	L	L	L	L	L	
Check lubrication for tuning shaft of main and pillion steps			\	L	L	L	L	L	L	L	
Main station frame, side support shaft lubrication check			\	L	L	L	L	L	L	L	
Check lubricant for brake and clutch lever shaft			\	L	L	L	L	L	L	L	
Check lubrication for bearing of rear fork shaft			\	L	L	L	L	L	L	L	
Check lubrication for driving chain			A	A	A	A	R	A	A	A	
Others	Battery voltage		\	I	I	I	I	I	I	I	
	Seal performance for brake oil tube		I	I	I	I	I	I	I	I	
	Brake liquid	2 years	I	I	I	I	I	I	I	I	
	Brake liquid level		I	I	I	I	I	I	I	I	
	Fr.& Rr. Brake pads		Do not allow the wear of the brake friction plate to exceed the minimum allowable thickness								
	Fr.& Rr. Brake switch		I	I	I	I	I	I	I	I	
	Check fuel evaporation system		I	I	I	I	I	I	I	I	
	Check tightness of fastening pars on body		I	I	I	I	I	I	I	I	
	Check leakage for Fr. & Rr. shock absorbers		I	I	I	I	I	I	I	I	
	SLIDER,DRIVE CHAIN		First 10000 km inspection, after every 20000 km replacement.								

Meaning of symbols: I: Inspection C: Clean R: Replacement A: Adjustment L: Lubrication

Ref. No.	Name	Position	Thread	Qty.	Torque	Ref. No.	Name	Position	Thread	Qty.	Torque
1	Fastening nut for air exhaust pipe	Front part of air exhaust pipe and engine	M7*1	4	15±1.5	18	Fixing bolt for left main footrest	Left main footrest and engine	M10*1.5	2	40±4
2	Air filter installation bolt	Air filter front end and frame	M6*1	1	9±1.35	19	Upper fixing bolt for right main footrest	Upper installation point of right main footrest and engine	M12*1.75	1	95±9.5
3	Wheel axle fixing screw	Front wheel and rear fork axle	M20*1.5	1	70±5	20	Lower fixing bolt for right main footrest	Lower installation point of right main footrest and engine	M10*1.5	2	40±4
4	Rear wheel connective plate fastening bolt	For assembling connective plate of rear wheel	M12*1.5	5	40±4	21	Pillion step fixing bolt	Pillion step and tail part of frame	M8*1.25(10.9)	4	30±3
5	Locking nut for rear wheel axle	Rear wheel axle	M24*1.5	1	100±7	22	Installation screw for speed sensor washer	Installation washer for speed sensor	M5*1	10	4.5±0.5
6	Brake pump installation bolt	Fixed front disc brake lower pump	M10*1.5	4	40±4	23	Fuel tank installation bolt	Fuel tank and rear holder	M8*1.25	2	22±2
7	Brake pump installation bolt	Fixed rear disc brake lower pump	M8	2	30±3	24	Tail rack installation bolt	Tail luggage rack and frame	M8*1.25	4	22±2
8	Disc brake hose bolt	Disc brake hose and lower pump	M10*1	3	35±3.5	25	ABS oil tube installation bolt	Bolt for ABS soft hose	M10*1	4	31±2.8
9	Disc plate fastening bolt	Disc brake plate and wheel hub	M8*1.25(10.9)	17	35±3.5	26	Assembly bolts for the middle, front, and rear sections of the muffler	Front and middle part of muffler and its body	M10*1.5	2	30±2
10	Fastening bolt for rear part of frame	Fix front and rear part of frame	M10*1.5	4	60±6	27	Assembly bolts for the middle, front, and rear sections of the muffler	Fasten muffler	M8*1.25	2	22±2
11	Engine fastening bolt	Fix engine	M12*1.75	8	75±7.5	28	Bumper bar connective piece installation bolt	Bumper bar connective piece and engine installation bolt	M8*1.25	2	22±2
12	Locking nut for steering stem	Assemble steering stem	M35*1	2	The 1st Piece: Loosen by 1/4 circle with 5.0N.m, the fasten by 35N.m, the 2nd piece: 2N.m, align the groove	29	Left bumper bar installation bolt	Installation for left bumper bar	M8*1.25	3	22±2
13	Locking bolt for steering stem	Assemble upper connective plate and steering stem	M28*1	1	100±10	30	Right bumper bar installation bolt	Installation bolt for right bumper bar, its connective piece and engine (Front)	M8*1.25	2	22±2
14	Handle bar fastening bolt	Fix handle bar	M8*1.25	4	24±2	31	Right bumper bar installation bolt	Installation bolt for right bumper bar, its connective piece and engine (Rear)	M10*1.5	1	40±4
15	Locking bolt for front shock absorber	Assemble front shock absorber	M8*1.25	6	18±1.8	32	Installation bolt for installation base of main stand	Installation base for main stand, engine and main footrest	M10*1.5	4	40±4
16	Locking screw for rear shock absorber	Assemble upper and lower part for rear shock absorber	M12*1.75	2	60±6	33	Installation screw for ignition switch	Installation screw for ignition switch	M8*1.25	2	18±1.8
17	Locking nut for side stand	Side stand	M10*1.25	1	40±6						

Please carefully and strictly make periodic maintenance according to requirement of this book.

- The maintenance in the table only the least user needs to do. In case your motorcycle is usually driving under bad conditions, the maintenance shall be more frequent than the table
- After a long driving in sandy weather or muddy road, the special maintenance is necessary.
- We suggest this kind of work shall be done by VOGÉ dealer.
- Correctly dispose the abandoned materials such as cleanser or waste oil, don't let them to be pollutions.
- The key for correct maintenance is the spare parts, in case you fail to confirm who made the parts, this kind of parts may lead to accident.
- We suggest this kind of work shall be done by VOGÉ dealer.

X. Maintenance for the motorcycle in long parking

Storage for motorcycle

- In case the motorcycle needs to park for a period without driving, the special maintenance is necessary, which need some special tools, equipment or technologies, because of this, we suggest these works shall be done by VOGÉ dealers.
- If you prefer to do these works by yourself, please do as below:
 - Totally replace for new oil.
 - Block the air inlet port of air filter and exhaust port of muffler by cloth with new oil, to avoid moisture get into engine,
 - Totally drain off the fuel in the fuel tank.
 - Remove the battery, then wash its surface by neutral soap water, meanwhile cleaning up the oxidizing material on its terminals.
 - Store the battery in a room with temperature above 0°C.
 - Adjust the tire pressure to stipulated one.
 - Totally wash up the motorcycle.
 - Spray the protective agent on rubber parts' surface.
 - Spread the protective wax for auto on the covering parts of this motorcycle.
 - Finally well cover the motorcycle by dry cloth and park the place with fine air ventilation.

The re-use

- Totally clean up the motorcycle. • Remove the cloth blocked the air inlet port of air filter and exhaust port of muffler.
- Totally replace the oil in engine and oil element. • Re-install the battery. • Start the motorcycle.

Caution

In case storage over 1 month, charge battery to full power, then cut off positive and negative terminal, to avoid excessive power consumption during storage period.

Protection for motorcycle

- According to the daily driving, usually wash the motorcycle and keep it clean and dry.
- Wash up the dirt, bird shit, asphalt or salt on motorcycle surface as quick as possible.
- Try best to cover the motorcycle by dry cloth, long time exposed under sunshine may make covering parts get aged or color fading.

Cleaning up for motorcycle

- Wash the motorcycle by cold water.
- Totally wash up the motorcycle by soft cloth and neutral cleanser.
- Don't wash the motorcycle by spray.
- Don't wash the motorcycle by high pressure water.
- When driving motorcycle in low temperature, high moisture, rain or after washed, there may be some moisture in the lights, turn on the light for a while the moisture may disappear, because there is design of ventilation hole, which are normal.

Danger

The wet brake may have poor braking performance, so please repeatedly test the brake system after motorcycle washed, and fast dry it up.



Maintenance download



Facebook

www.vogeglobal.com