

Engine KEL600

Service Manual

LXFD0901-054



Foreword

There are more and more motorcycles getting onto market with each passing day, and new structure and technologies are also adopted. For all the Loncin users and service workers know well about the maintenance, adjustment and repair for engine KEL600, we made this service manual and hope which bring you more convenience when you need them.

All the data in this book including diagrams, performance and other data are all the latest until it printed. The Loncin motor. co. ltd. reserves the right for further revision without any notice in advance. Any part in this book belongs to Loncin copyright, any person or company is unable to re-print unless got Loncin writing authorization in advance.

Content list

1. Summary.....	错误!未定义书签。
Maintenance rules.....	错误!未定义书签。
Specification.....	错误!未定义书签。
Torque.....	错误!未定义书签。
Positions for sealing and lubrications.....	错误!未定义书签。
2. Maintenance.....	错误!未定义书签。
Maintenance information.....	错误!未定义书签。
Maintenance specification.....	错误!未定义书签。
Breathing tube for crankcase.....	错误!未定义书签。
Spark plug.....	错误!未定义书签。
Valve clearance.....	错误!未定义书签。
Oil in engine.....	错误!未定义书签。
Secondary oil filter.....	错误!未定义书签。
Engine idling.....	错误!未定义书签。
Clutch.....	错误!未定义书签。
3. Cooling system.....	错误!未定义书签。
Maintenance information.....	错误!未定义书签。
Cooling system specification.....	34
Troubleshooting.....	错误!未定义书签。
System procedure mode.....	错误!未定义书签。
System test.....	错误!未定义书签。
Replace coolant.....	错误!未定义书签。
Thermostat.....	错误!未定义书签。
Water pump.....	错误!未定义书签。
Tube joint.....	错误!未定义书签。
Replace stud bolt.....	错误!未定义书签。
4. Lubrication system.....	错误!未定义书签。
Maintenance information.....	错误!未定义书签。
Lubrication system.....	错误!未定义书签。
Troubleshooting.....	错误!未定义书签。

Lubrication system diagram.....	错误!未定义书签。
Check oil pressure.....	错误!未定义书签。
Oil pump.....	错误!未定义书签。
Pressure relief valve.....	错误!未定义书签。
Oil suction tube.....	错误!未定义书签。
Water-oil thermal exchanger.....	错误!未定义书签。
5. Cylinder head and valve	错误!未定义书签。
Maintenance information	错误!未定义书签。
Cylinder head/Valve specification.....	错误!未定义书签。
Troubleshooting	错误!未定义书签。
Components layout	57
Cylinder compression test.....	错误!未定义书签。
Cylinder head cover.....	59
Camshaft.....	错误!未定义书签。
Swinging arm	错误!未定义书签。
Cylinder head.....	70
Removal.....	错误!未定义书签。
Tensioner adjustive rod.....	错误!未定义书签。
Timing chain/Sprocket wheel	79
6. Clutch and gearshift device	错误!未定义书签。
Maintenance information	错误!未定义书签。
Clutch and gearshift device specification.....	错误!未定义书签。
Troubleshooting	错误!未定义书签。
Components layout	错误!未定义书签。
Right crankcase cover	错误!未定义书签。
Clutch.....	错误!未定义书签。
Primary driving gear	错误!未定义书签。
Gearshift system.....	98
7. Magneto and starting clutch	错误!未定义书签。
Maintenance inforation.....	错误!未定义书签。
Magneto and starting clutch specification.....	104

Troubleshooting	错误!未定义书签。
Components layout	错误!未定义书签。
Left crankcase cover	错误!未定义书签。
Magneto stator and trigger	错误!未定义书签。
Magneto rotor	错误!未定义书签。
Starting clutch.....	错误!未定义书签。
8. Case body and transmission system	错误!未定义书签。
Maintenance information	错误!未定义书签。
Case body and transmission system specification	错误!未定义书签。
Troubleshooting	错误!未定义书签。
Components layout	错误!未定义书签。
Transmission system	错误!未定义书签。
Case body	121
9. Crankshaft, piston, cylinder body and balancing shaft	错误!未定义书签。
Maintenance information	错误!未定义书签。
Specification for crankshaft, piston, cylinder body and balancing shaft.....	错误!未定义书签。
Troubleshooting	错误!未定义书签。
Components layout	错误!未定义书签。
Crankshaft.....	错误!未定义书签。
Mainshaft journal pads.....	错误!未定义书签。
Crankshaft pin pads.....	错误!未定义书签。
Piston/Cylinder body	错误!未定义书签。
Piston nozzle.....	错误!未定义书签。
Balancing shaft	153

1. Summary

Rules for maintenance

1. Please adopt the Loncin motor co. ltd. produced or suggested spare parts, lubricant or other auxiliary materials when maintenance is necessary. In case materials were adopted fail to meet Loncin standard, it may damage your motorcycle.
2. When maintenance is necessary, please adopt the tools, bolt, nut and screw in metric standard, the ones out of metric standard such as imperial standard are not allowed, because they are not interchangeable to metric ones.
3. When parts were replaced or re-assembled, please also replace their washer, o-ring, split pin and locking piece.
4. Please fasten the bolt or nut with bigger diameter or inside first, then fasten the rest in alternative angle sequence, unless there is another specially stipulated sequence.
5. Wash up the removed parts by cleanser. Coat the moving surface with lubricant before re-assembling.
6. When re-assembled, please check and confirm the correct re-assembly and proper operation, turn, move and operate them for checking.
7. Dispose the used oil, lubricant, pollutants and abandoned parts by strictly following laws and other state regulations.

Specification

Normal specification

	Items	Data
Engine	Type	LX276MS
	Displacement	580.7ml
	Cylinders and angle	左: 1, 右: 2; 19°
	Cylinder bore × Stroke	76mm×64mm
	Combustion chamber	18.5ml
	Compression ration	11.5: 1
	Max. power and its rotation	45kW/9000rpm
	Max. torque and its rotation	55N.m/6500rpm
	Air valve device	Cam at top
	Lubrication system	Forced pressure +Splashing lubrication
	Cooling system	Water cooling
	Engine net weight	53.5kg
Transmission system	Clutch	Multiple wet layers
	Gear box	International 6 gears
	Primay transmission ratio	1.826
	End transmission ratio	2.87
	Gear transmission ratio	1 st : 3.285 2 nd : 2.105 3 rd : 1.600 4 th : 1.300 5 th : 1.150 6 th : 1.043
	Gearshift method	1-N-2-3-4-5-6
Electrical system	Ignition system	FTI 1-2
	Starting system	Complete electric starting
	Lighting system	Battery
	Spark plug specification	CPR8EA-9 (NGK)
	Spark plug clearance	0.8-1.0mm
	Rectifier regulator	3 phases complete wave regulator

Cooling system specification

Items		Specification
Coolant capacity	Heat radiator and engine	1.6 L
	Tank	\
Relief pressure for heat radiator cover		108-137kPa
Thermostat	Initial temperature	80-84°C
	Complete temperature	95°C
	Valve rise	8mm
Coolant we suggested		With ethanol without silicate
Standard thickness of coolant		Mixture with distilled water by 1:1

Lubrication system specification

Unit: mm

Items		Standard	Maintenance limit
Oil capacity	When oil replaced	2.8 L	—
	When oil filter replaced	3 L	—
	When engine broke up	3.4 L	—
Oil we suggest		The engine oil we suggest: SG10W-40 API quality grade: SG or higher (Please don't adopt energy saving oil which marked up on API service label) JASO T903 Standard: MA Viscosity: SAE10W-40	—
Opening pressure for oil pressure sensor		At 80°C or normal temperature : 15~19.6Kpa	—
Oil pump rotor	Clearance between impeller tips	0.15	0.20
	Middle	0.12-0.21	0.30

	clearance		
	Clearance between sides	0.035-0.095	0.125

Cylinder head/Valve specification

Unit:mm

Items		Standard	Maintenance limit	
Pressure in cylinder of electrical starting		$\geq 1200\text{KPa}$	—	
Valve clearance	Air inlet	0.10~0.15	—	
	Air exhaust	0.15~0.20	—	
Swinging arm and its shaft	Inner diameter of arm	In/Exhaust	8.013-8.028	8.038
	Outer diameter of shaft	In/Exhaust	7.983-7.995	7.973
	Clearance between arm and shaft	In/Exhaust	0.018-0.041	0.065
Camshaft Camshaft	Height of protrusion	Air inlet	35.8022-35.8622	35.7722
		Air exhaust	35.8019-35.8619	35.7719
	Clearance between journal and hole			0.10
	Height of protrusion		Air inlet	0.04
Valve and its guiding tube	Rod diameter of valve	Air inlet	4.475-4.490	4.465
		Air exhaust	4.465-4.480	4.455
	Inner diameter of valve guiding tube	In/Exhaust	4.500-4.512	4.54
	Clearance between valve rod and its guiding tube	Air inlet	0.01-0.037	0.075
		Air exhaust	0.02-0.047	0.085
	Height of guiding tube	In/Exhaust	12.90-13.20	—
	Width of gate line for base ring	Air inlet	1.0-1.20	1.5
Free length of valve spring	Inner spring	34.5	33.3	
	Outer spring	41.85	40.65	
Flatness of cylinder head		—	0.05	

Clutch and gearshift device specification

Unit: mm

Items		Standard	Maintenance limit
Free travel for clutch lever		10-20	—
Clutch	Spring free length	45	43.8
	Friction plate thickness	2.92-3.08	2.82
	Driving plate flatness	—	0.05
Clutch collar	Inner diameter	21.992-22.007	22.017
	Outer diameter	27.995-28.008	27.985
Outer diameter at main shaft of clutch collar		21.967-21.980	21.957

Magneto and starting clutch specification

Unit: mm

Items	Standard	Maintenance limit
Outer diameter for shaft jacket of starting plate shaped gear	51.705-51.718	51.685
Inner diameter for outer case of starting clutch	68.364-68.39	68.40

Case body and transmission system specification

Unit: mm

Items		Standard	Maintenance limit	
Transmission mechanism	Inner hole diameter of gear	M5	28.000-28.021	28.04
		C1	24.007-24.028	24.04
		C2	31.000-31.025	31.04
	Outer diameter of shaft jacket	M5, M6	27.959-27.980	27.94
		C2	30.970-30.995	30.94
		C3, C4	30.950-30.975	30.93
	Clearance between gear and	M5	0.020-0.062	0.10
		C2	0.005-0.055	0.07

	shaft jacket			
	Inner diameter of shaft jacket	M5	25.000-25.021	25.04
		C2	28.000-28.021	28.04
	Shaft diameter of main shaft	Match to shaftjacket of M5	24.967-24.980	24.96
		Match to shaftjacket of C2	27.967-27.980	27.95
	Clearance between shaft and its jacket	M5, C2	0.020-0.054	0.07
Turning fork and its shaft	Diameter for fork shaft		11.957-11.968	11.947
	Inner diameter for fork		12.000-12.018	12.028
	Fork tip thickness		5.93-6.00	5.92

Specification for crankshaft, piston, cylinder body and balancing shaft

Unit: mm

Items		Standard	Maintenance limit	
Crankshaft	Clearance at bigger end of connecting rod	0.1-0.25	0.3	
	Clearance between shaft pad on bigger end of connective rod and the shaft	0.030-0.052	0.06	
	Clearance between journal of crankshaft and shaft pad	0.018-0.036	0.05	
	Runout	—	0.03	
Cylinder	Cylinder bore	76.000-76.015	76.045	
	Roundness loss	—	0.10	
	Taper	—	0.10	
	Cylindricity	—	0.10	
Piston, piston pin and piston rings	Diameter of basic circle for piston	75.965-75.980	75.915	
	Diameter for pin' s hole	17.002-17.008	17.018	
	Diameter of piston pin	16.994-17.000	16.984	
	Clearance between piston and its pin	0.002-0.014	0.034	
	Closing clearance of piston ring	1 st ring	0.15-0.30	0.35
		2 nd ring	0.20-0.35	0.40
		Oil ring	0.20-0.70	1.0
	Clearance between piston ring and its groove	Clearance between 1 st ring and its groove	0.030-0.070	0.10
Clearance between 2 nd ring and its groove		0.020-0.060	0.08	
Clearance for cylinder matching		0.020-0.050	0.10	
Smaller end of connecting rod and its inner diameter		17.013-17.025	17.035	
Matching clearance between connecting rod and its pin		0.013-0.031	0.07	

Torque Standard torque

Fastening piece type	Torque N. m	Fastening piece type	Torque N. m
Bolt and nut 5mm	5.2	5mm screw	4.2
Bolt and nut 6mm	11	6mm screw	11
Bolt and nut 8mm	22	6mm flange bolt (Head 8mm, smaller flange)	10
Bolt and nut 10mm	34	6mm flange bolt (Head 8mm, bigger flange)	11
Bolt and nut 12mm	54	6mm flange bolt (Head 10mm) and nut	11
		Flange bolt and nut 8mm	27
		Flange bolt and nut 10mm	39

Engine torque

Items	Qty.	Thread diameter mm	Torque N. m	Note
Spark plug	2	10	16	
Swinging arm shaft and bolt	2	12	16	Coat thread with oil and replace washer for a new one
View hole cap	1	45	12	Coat thread with grease
Engine oil drainage bolt	1	12	28	
Secondary oil filter	1	20	12	Coat surface of seal ring with lubricant
Tube joint of secondary oil filter	1	20	27	Coat head with Loctite from place of 6.5mm

Cooling system

Items	Qty.	Thread	Torque N. m	Note
-------	------	--------	-------------	------

		diameter mm		
Water pump installation bolt	3	6	11	
Water pump cover bolt (Include water drainage bolt)	2	6	11	
Installation bolt for tube joint	2	6	11	
Bolt for location pillar	1	7	14	
Bolt for thermostat cover	2	6	11	

Cylinder head and valves

Items	Qty.	Thread diameter mm	Torque N.m	Note
Cylinder head bolt	6	9	48	Coat thread and base surface with oil
Cylinder head bolt	2	6	11	
Camshaft bracket bolt	12	6	12	
Valve swinging arm shaft bolt	2	10	16	
Cylinder head cover bolt	4	6	11	
Installation bolt for oil-gas separator plate	2	6	11	
Installation bolt for secondary air inlet	2	6	11	

Tension bolt for chain chamber(Right side of cylinder head)	1	6	11	
Engine sensor (Temperature)	1	12	14	Coat thread with sealant
Installation bolt for timing driven sprocket wheel	6	6	11	
Installation bolt for tensioner	2	6	11	
Seal bolt for tensioner tail	1	6	8	

Clutch and gearshift device

Items	Qty.	Thread diameter mm	Torque N.m	Note
Driven wheel bolt for oil pump	1	6	11	Coat thread with Loctite
Locking nut for central case	1	18	130	Coat thread and base surface with oil
Bolt for primary driving wheel	1	10	95	Coat thread and base surface with oil
Bolt for check plate	1	6	11	Coat thread with Loctite
Location bolt for gearshift arm	1	8	28	Coat thread with Loctite
Lift plate bolt	3	6	11	
Pressure plate bolt for gearshift arm	1	6	11	Coat thread with Loctite

oil-seal				
Limit plate bolt for gearshift arm	1	6	11	Coat thread with Loctite
Right crankcase cover bolt	14	6	11	

Magneto and starting clutch

Items	Qty.	Thread diameter mm	Torque N. m	Note
Starting clutch fastening bolt	6	8	28	Coat thread with Loctite
Magneto rotor bolt	1	12	135	Coat thread and base surface with oil
Magneto stator bolt	4	6	11	Coat thread with Loctite
Trigger fixing bolt	2	6	11	Coat thread with Loctite
Left crankshaft cover bolt	11	6	11	

Case body and transmission system

Items	Qty.	Thread diameter mm	Torque N. m	Note
Checkplate for balancing shaft/main shaft bearing	4	6	11	Coat thread with Loctite
Pressure plate for main shaft collar	1	6	11	Coat thread with Loctite

Locating bolt for gearshift drum bearing	2	6	11	Coat thread with Loctite
Bolt for main shaft journal	6	8	5+15+120°	Coat with oil and replace bolt for a new one
Bolt 10mm for crankcase	1	10	40	
Bolt 8mm for crankcase	3	8	25	
Bolt 6mm for crankcase	10	6	11	

Crankshaft, piston, cylinder body and balancing shaft

Items	Qty.	Thread diameter mm	Torque N.m	Note
Connective rod bolt	4	8	5+15+90°	Coat thread and base surface with oil

Positions for sealing and lubrication

Engine

Material		Position	Note
Sealant	1596	Contact surface of crankcase Seal ring for cylinder head cover	
	1590	Wire outlet joint of magneto	
Oil in engine		Complete surface of inner and outer rotor of oil pump Complete surface for swinging arm shaft Working surface for swinging arm Sliding surface of rod end of valve rod Complete surface of timing chain Surface for journal of camshaft and the cam Inner surface of cylinder hole Outer surface of piston, piston pin's hole and groove of piston ring Outer surface of piston pin Complete surface of piston ring Complete surface of clutch friction plate Sliding surface of clutch pushing rod Rod part of gearshift spindle and turning plate Complete surface of double gear shaft Complete surface of starting clutch Complete surface of gearshift fork shaft Inner surface of shaft pad on bigger end of connective rod of crankshaft Inner hole for smaller end of connective rod for crankshaft Gear (Primary, crankcase, starting deceleration) Sliding surface of plate shaped gear	

	Turning area of each bearing Surface for each o-ring	
Molybdenum disulfide	Swinging arm Swinging arm shaft Camshaft surface Cylinder head camshaft hole	
Multi-functional lubricant	Seal ring of starting motor	
Degreaser	All contact surface	

2. Maintenance

Maintenance information

Summary

- Please lay motorcycle on horizontal ground before all the operations.

Tool

Cap-shaped wrench for secondary oil filter

帽式机油精滤器扳手

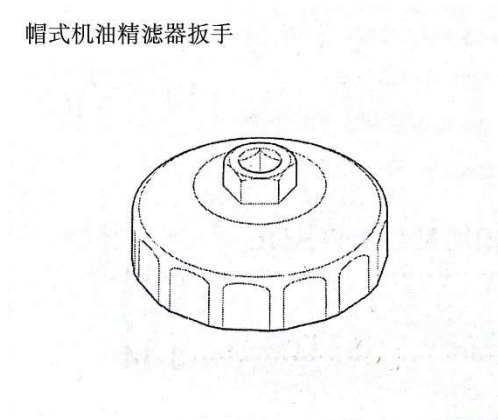

Specification for maintenance

Please inspect according to <Periodic Maintenance table> in User Manual.

I: Inspection, clean it up, adjust, lubricate or replace when it was necessary. C: Clean up. A: Adjust. L: Lubricate.

The maintenance below need you know something about machinery. Some items (Especially with mark * and **), they may need more skill or tools and information.

Form list for periodic maintenance

Ref. No.	Period Items	X1000km	1	6	12	18	24	30	36
		Month	1	6	12	18	24	30	36
*1	Spark plug						R		
*2	Oil in engine		R	R	R	R	R	R	R
*3	Secondary oil filter		R	R	R	R	R	R	R
*4	Valve clearance		Each 42000km, I						
*5	Coolant		I	I	I	I	R	I	I
*6	Cooling system			I	I	I	I	I	I
*8	Fuel tube			I	I	I	I	I	I
9	Breathing tube of crankcase			C	C	C	C	C	C
10	Secondary air supplement system				I		I		I
11	Clutch system		I	I	I	I	I	I	I

Caution: 1. More frequent maintenance is necessary in case usually drive under dusty or wet conditions. .

2. *Means special tools, data or skill is necessary, which needs be done by Loncin dealer.

3. *The maintenance needs be done in the form list the one which arrived first between mileage and working life.*

Caution:

- When driving in rain or under full speed, when washed or oppositely put the motorcycle, the more maintenance is needed. Check the sediment in breathing tube by viewing its transparent part. Pull off plug [1] of cleaning tube for air filter, guide sediment into suitable container, the get tube plug in place once again.

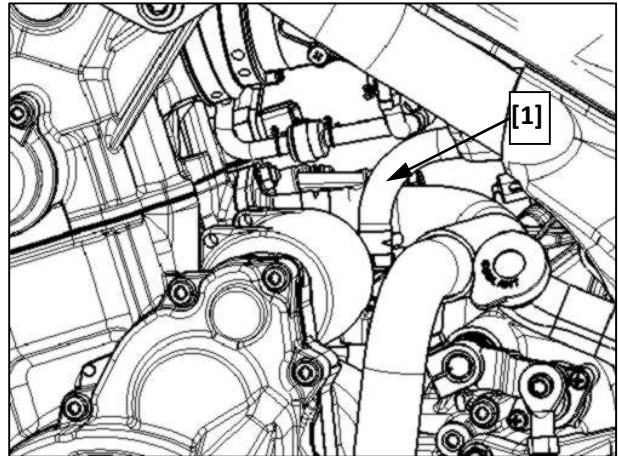

Remove fuel tank and firmly hold it. Check and confirm if there is crack, aging, damage or flexibility on waste gas tube [1] of crankcase.

Replace waste gas tube for a new one if it is necessary.

Re-assemble fuel tank.

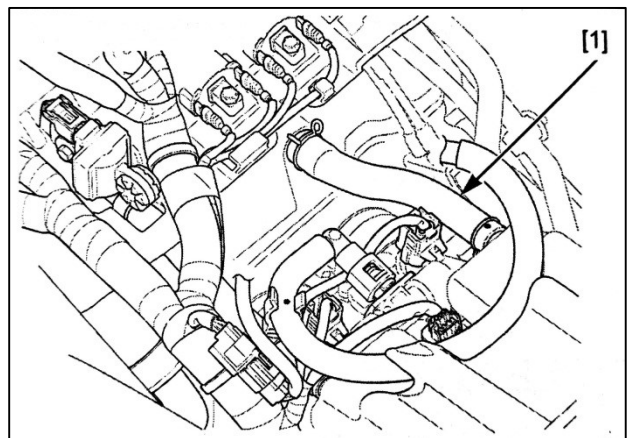

Spark plug

Remove fuel tank.

Remove spark plug [1].

Caution:

Before removing the spark plug, blow the surroundings of its base by air gun, meanwhile making sure there is not any dust dropped into combustion chamber.

Check and confirm if there is crack or damage on insulator, also confirm if there is damage, dirt or color changing on terminal, please replace the spark plug if it is necessary.

Check spark plug:

Clean up the terminal of spark plug by its cleaner for it only or iron wire.

Check the clearance between central terminal and the side terminal by feeler gauge.

Clearance for spark plug: 0.80-1.0mm

In case it is necessary, get the side terminal bent to adjust the clearance.

Assemble spark plug and turn it to cylinder head, then turn it to given torque.

Torque: 16N • m

Assemble the fuel tank.

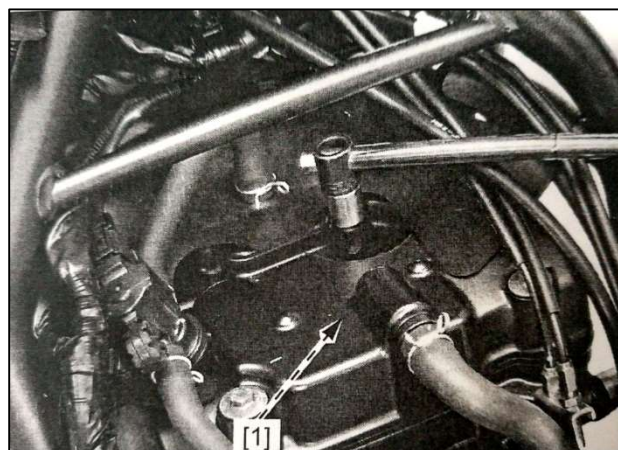

Valve clearance

Inspection

Caution:

Please check and adjust valve clearance when the engine is cold (Under 35 °C)

Remove the parts below:

- Cylinder head cover and its seal ring
- View window cap and o-ring
- Turn crankshaft clockwise, get basic circle of camshaft on for air intake/exhaust on left cylinder align to valve swinging arm.
- Insert feeler gauge with standard specification between basic circle of camshaft and swinging arm of air intake

and exhaust valve on left cylinder, then inspect the valve clearance for 4 air intake and exhaust valves on left cylinder, whose standard clearance shall be: Intake:0.10~0.15, while exhaust shall be : 0.15~0.20.

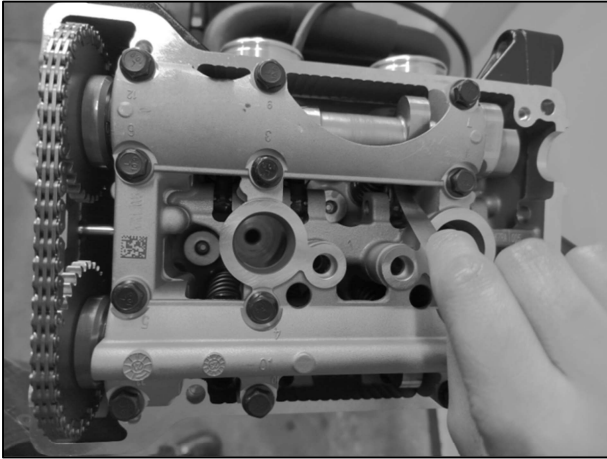

- Under condition above, keep turning crankshaft clocowise, get basic circle of camshaft on for air intake/exhaust on right cylinder align to valve swining arm
- Insert feeler gauge with standard specification between basic circle of camshaft and swinging arm of air intake and exhaust valve on right cylinder, then inspect the valve clearance for 4 air intake and exhaust valves on left cylinder, whose standard clearance shall be: Intake:0.10~0.15, while exhaust shall be : 0.15~0.20.

Caution:

Adjustment

In case the valve clearance is out of range above, please remove the bracket of camshaft and remove it, then open swinging arm for valve, then absorb the adjustment washer for valve out by magnetive bar, replace the adjustment washer for valve for a suitable one then adjust the valve clearance into stipulated range, whose details is as below:

- Turn crankshaft clockwise, get scale mark [1] T1 on primary driving gear align to

Take each valve clearance into record for selection reference of adjustment for valve clearance.

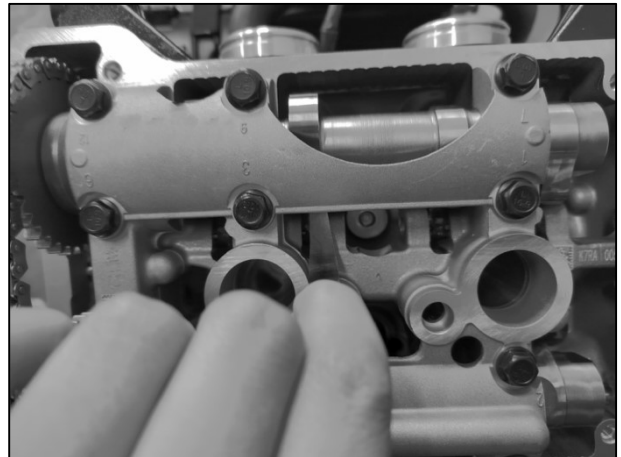

groove [2] on right case cover, while making sure timing mark "IN" and "EX" on timing driven gear are getting aligned to surface of cylinder head, the mark "IN" [3] point to air intake side, whole mark "EX" point to the side of air exhaust.

Caution:

In case timing mark is not at given place, keep turning crankshaft by 360°, get scale mark T1 on driving gear getting aligned to groove on right cover once again.

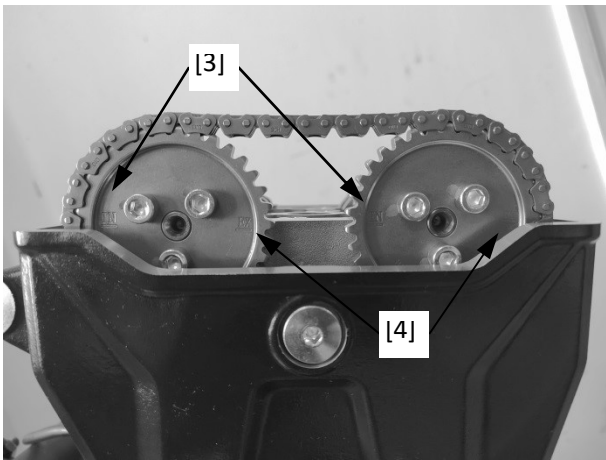
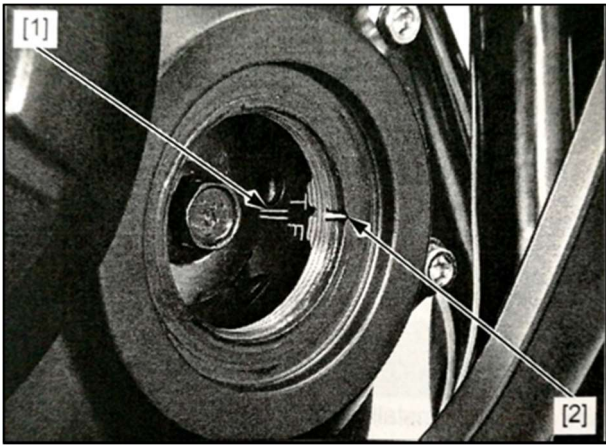

- Remove bolt [1] at tail part of tensioner, installation bolt [2], shim [3] for bolt and tensioner [4] and its gasket, then move adjustable stud of tensioner backwards completely (Clockwise turning) and hold it by tool for it only.

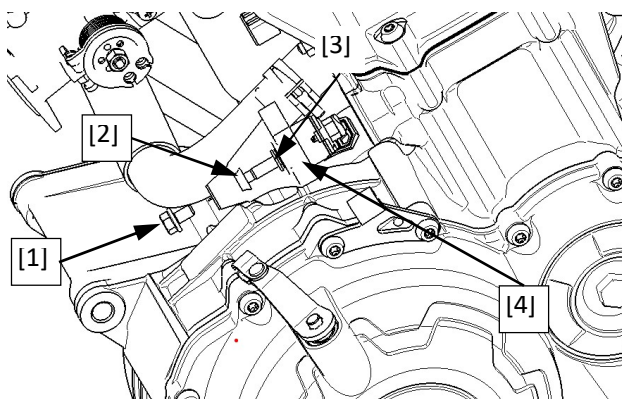

- Remove bolt of camshaft's bracket, the brack and camshaft kit.

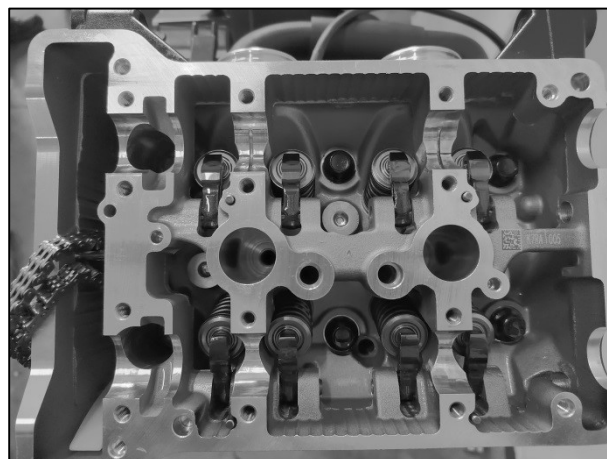

Caution:

- To prevent damage on cylinder head, camshaft and its bracket, please loosen by referring sequence number 12 → 1 on camshaft bracket
- Please don't remove installation bolt on timing driven gear on camshaft.

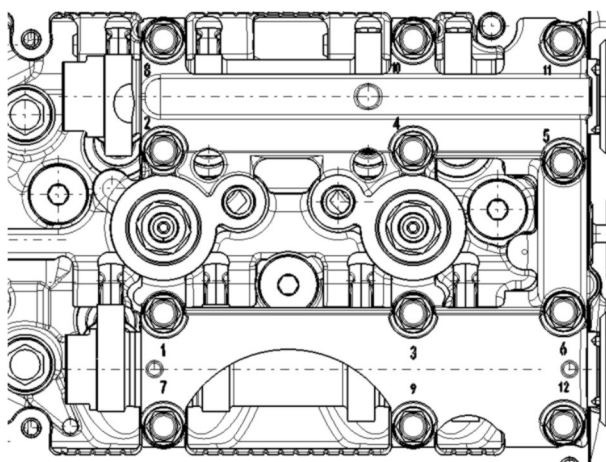

- Open valve swinging arm and take out adjustment shim of valve.

Caution

- *To prevent shim dropping into crankcase and hole of spark plug, please mark up all the shims for a correct re-assembly.*
- *Removal for shims may be easier by tweezers or magnetic iron.*

Measure thickness for washer [1] and take it into record.

Caution:

- There are washers of 89 different thickness for selection, whose difference for thickness between adjacent two are 0.01mm (1.72-2.60mm)

Calculate thickness for new washer by equality below:

$$A=(B-C)+D$$

- A: Thickness for new washer
- B: Take valve clearance into record
- C: Fix the midpoint of valve clearance
- D: The thickness for removed washer

- Coat end part of valve rod with oil.
Assemble new shim [1] to valve spring base to its original position.

Coat the complete surface of valve adjustment shim with oil.

Close valve swinging arm [2].

- Coat journal [3] of camshaft with oil, make sure crankshaft is at installation condition, suspend timing chain on timing driven gear, assemble air intake and exhaust

camshaft, meanwhile making sure timing mark “IN” on timing driven gear is aligned to cylinder surface and face to air intake side, then gets aligned to “EX” on cylinder and face to air exhaust side, the assemble camshaft bracket and fasten bolt with fastening torque of **12N.m**.

Caution:

Fasten bolts for camshaft bracket by twice according to sequence number 1 →12 on it with fastening torque of 5N.m →12N.m.

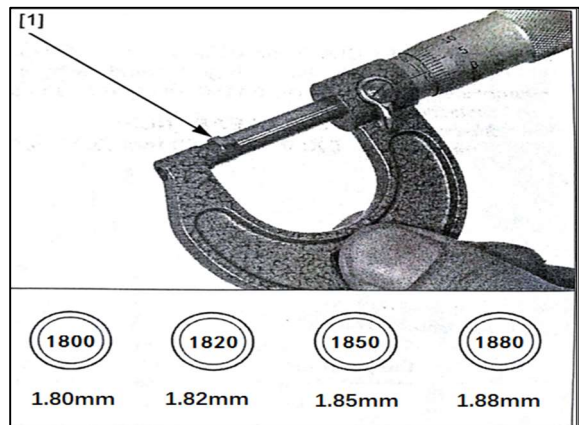
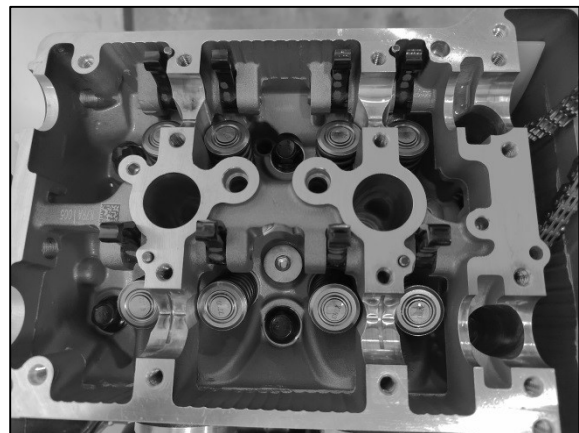

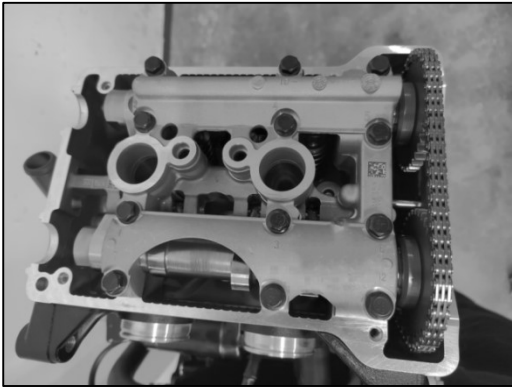
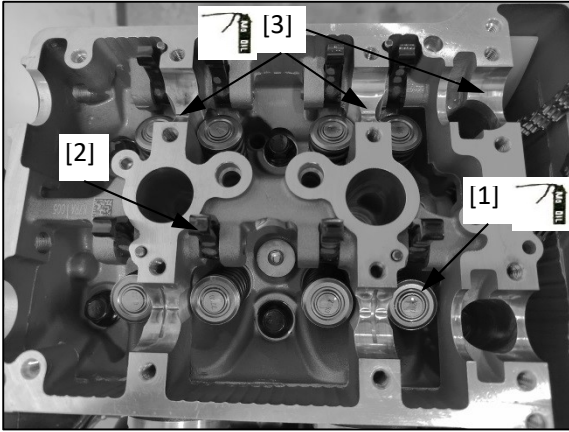

- Replace gasket of tensioner for a new one, then assemble tensioner, installation bolt and shim of bolt, then remove special tool to confirm tensioner already bounced out, installation torque for bolt is 11N.m, assemble bolt on tail of tensioner with fastening torque of 8N.m.
- Turn crankshaft above 2 rounds, measure valve clearance once again according to method above.
- Replace o-ring [1] for a new one and assemble it into groove on view hole cap. Coat thread [2] of view hole cap with lubricant, then assemble the cap in place and fasten to given torque.

Fastening torque: 12N.m

Assemble cylinder head cover

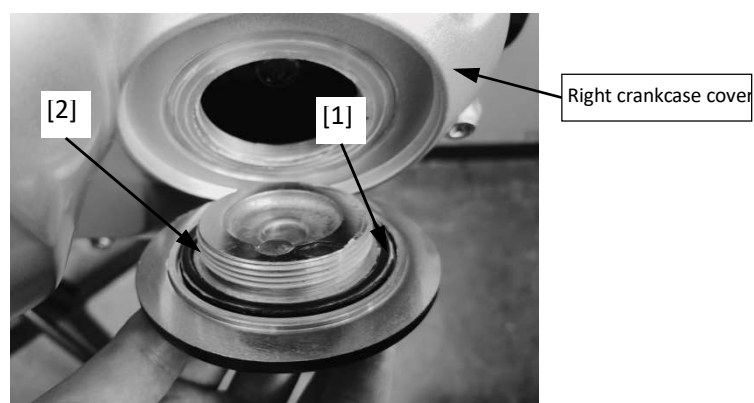
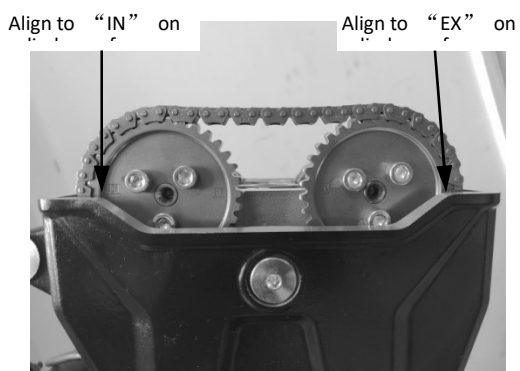

Oil in engine

Check oil level

Start engine and idly run it for 3-5 inutes.

Stop engine and wait for 2-3 minutes.

Keep motorcycle on horizontal ground and upright.

Check oil leve through view window.

In case the oil level is lower than the lowest line [1], remove oil plug [2], then fill up with given specification of oil to upper line [3] on crankcase.

Given specification of oil: SG10W-40

Quality grade of API: SG or higher

(Please don' t adopt the oil with round API service label and marked as energy saving)

JASO T903 standard: MA

Viscosity: SAE10W-40

Check if the o-ring for oil plug is fine, please replace if it is necessary.

Coat surface of o-ring with oil.

Re-assemble oil plug.

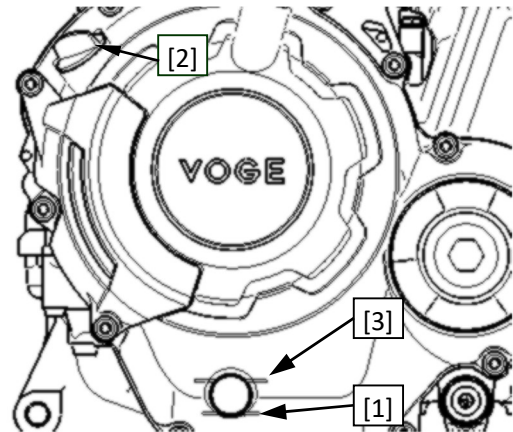

Replace oil

Heat up engine.

Stop engine and remove oil plug [1].

Remove oil drainage bolt [2] and washer [2], then drain off oil.

When oil completely drained off, assemble oil drainage bolt and replace washer for a new one.

Fasten oil drainage bolt go given torque.

Torque: 28 N.m

Fill up crankcase with given oil.

Oil capacity:

When drained off: 2.8L

When secondary oil filter replaced: 3.0L

When broke up: 3.4L

Check oil level:.

Make sure there is not any oil leaks.

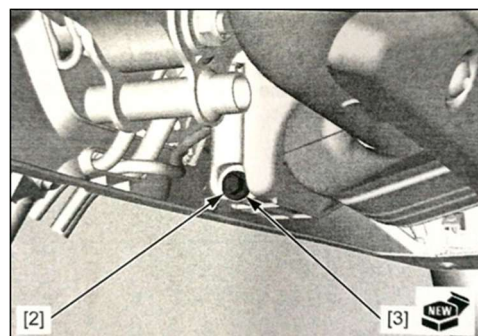
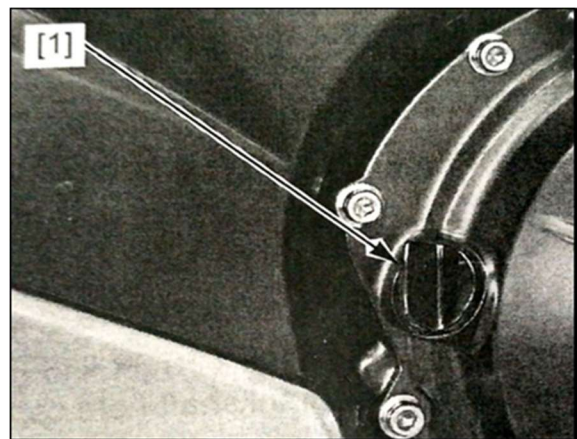

Secondary oil filter

Drain off oil.

Remove oil filter [1] by tool for it only.

Tool: Cap-shaped oil filter wrench [2]

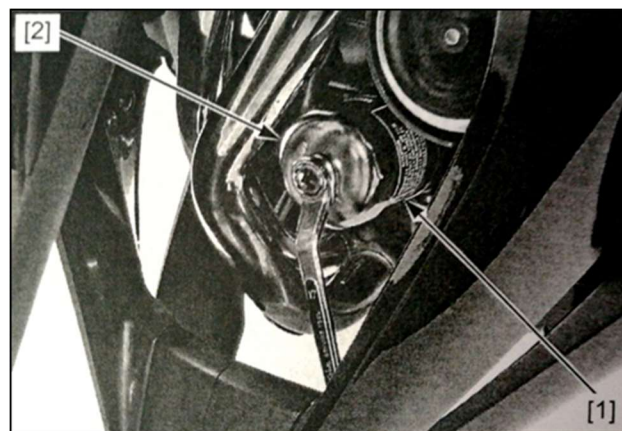

Assemble tube joint for secondary oil filter and fasten to given torque.

Torque: 24 N • m

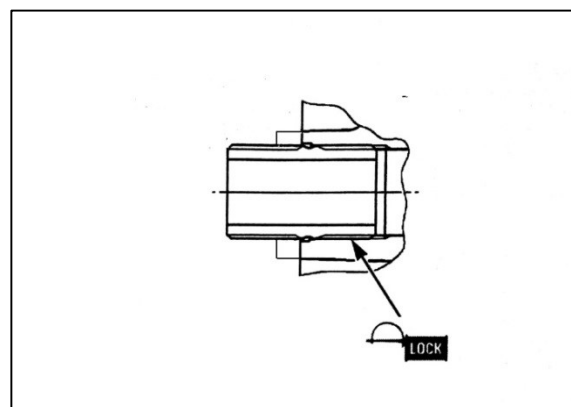

Coat thread [1] of new secondary oil filter and its o-ring with oil.

Assemble secondary oil filter and fasten to given torque.

Tool: Cap-shaped oil filter wrench [2]

Torque: 12 N.m

Fill up crankcase with given oil.

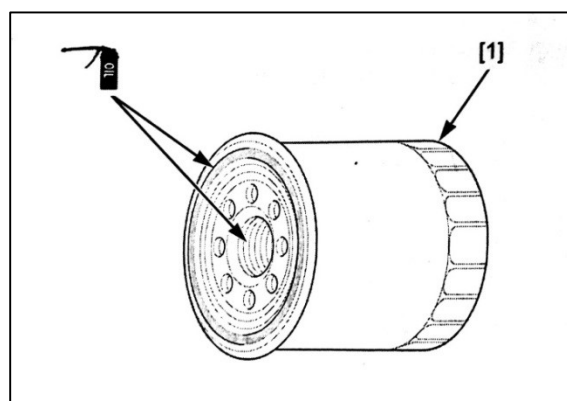

Engine idling

Caution:

- When all engine maintenance are finished and confirmed they are in given range, then check idling problems.
- Before checking idling, inspect items below:
 - Malfunction indicating light is not flashing
 - Condition of spark plug
 - Condition for element of air filter
 - Throttle switch and free play for throttle lever.
- The idling malfunctions could be precisely checked only when engine is hot. Start engine, heat it to normal working temperature, then idly run it and check its idling. Check idling.

Idling:1300±100

In case the idling is out of maintenance limit, please check the parts below:

- Malfunction on engine end or air intake
- Operation for idling control valve

Clutch

Check if there is distortion or damage of clutch cable. Lubricate it if it is necessary.

Check free play of clutch lever and its end part.

Free play:10-20mm

The tiny adjustment could be done by the adjustor on clutch lever.

Loosen locking nut [1], turn the adjustor [2] according demands.

Hold adjustor, meanwhile fastening locking nut.

In case get passed line range of adjust, the precise free play could not be got, at this moment, please adjust the main adjustor.

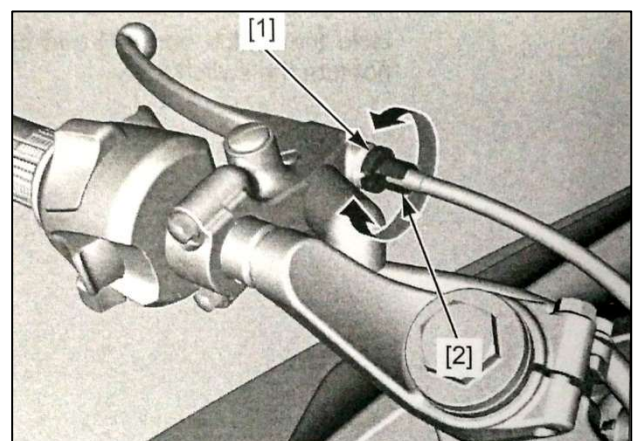
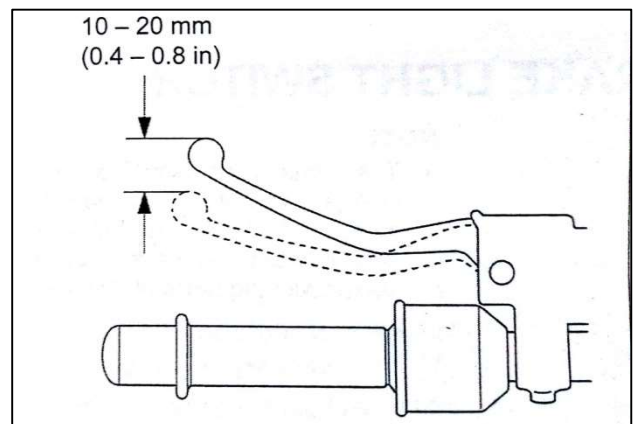

Main adjustment is through adjusting the nut [1] on operation arm for clutch.

Loosen locking nut [1], turn the adjustor [2] according to demands.

Hold adjustor, meanwhile fastening the locking nut.

In case failed to get correct free play of clutch, or the clutch is skidding when driving, please break down and check clutch.

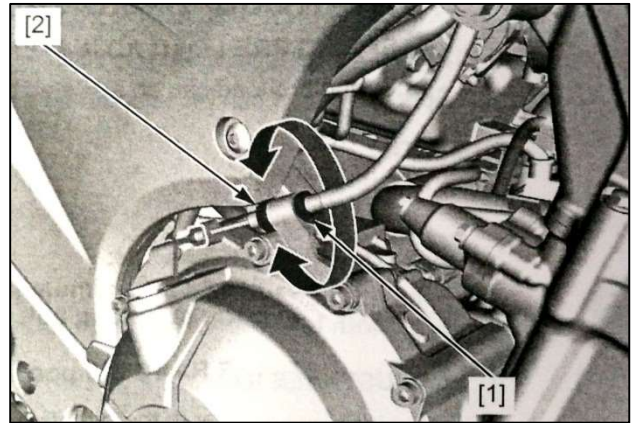

3. Cooling system

Maintenance information

Summary

 **Warning**

Please don't remove the cover of heat radiator when the engine and radiator completely cooled down, otherwise the coolant may inject or splash out and get your injured.

The coolant with silicate solvent of anti-corrosion may accelerate the wear-out of seal ring on water pump and block up the passage of heat radiator.

Use the running water may damage the engine

- Fill up the sub tank with coolant, except filling up of draining off, please don't remove the cover of heat radiator.
- The engine needn't be removed from frame when maintaining the cooling system.
- The coolant touches the painting surface is not allowed.
- Check the leakage when the cooling system was maintained by the tester of cooling system.
- Check by coolant temperature indicator/Water temperature sensor.
- Check the relay of cooling fan's controller.

Cooling system specification

Items		Speicification
Coolant capacity	Heat radiator and engine	1.6 L
	Tank	\
Relief pressure for heat radiator		108-137kPa
Thermostat	Initial	80-84°C

	temperature	
	Complete temperature	95°C
	Valve rise	Not smaller than 8mm
Coolant we suggest		Coolant with ethanol without silicate
Standard density of coolant		Mixture with distilled water by ratio of 1:1

Troubleshooting

Too high the engine temperature

- Malfunction in coolant temperature indicator/Water temperature sensor
- The thermal valve failed to be opened
- Malfunction on heat radiator' s cover
- Coolant is not enough
- Passage, soft hose and water tube of heat radiator blocked up
- Air got into circulation system
- Malfunction in motor of cooling fan
- Malfunction in relay of cooling fan' s controller
- Malfunction in water pump

Too low the engine temperature

- Malfunction in coolant temperature indicator/Water temperature sensor
- The thermal valve was opened
- Malfunction in relay of cooling fan' s controller

Coolant leakage

- Defect on machinery structure of water pump
- O-ring gets aged
- Malfunction on cover of heat radiator

- Gasket of cylinder head gets damaged or aged
- The joint of soft hose or tube clamp get loose
- Soft hose gets damaged or aged
- Heat radiator is broken
- The cover of thermostat or tube joint of water pump' s cover is flexible.

System

procedure

mode

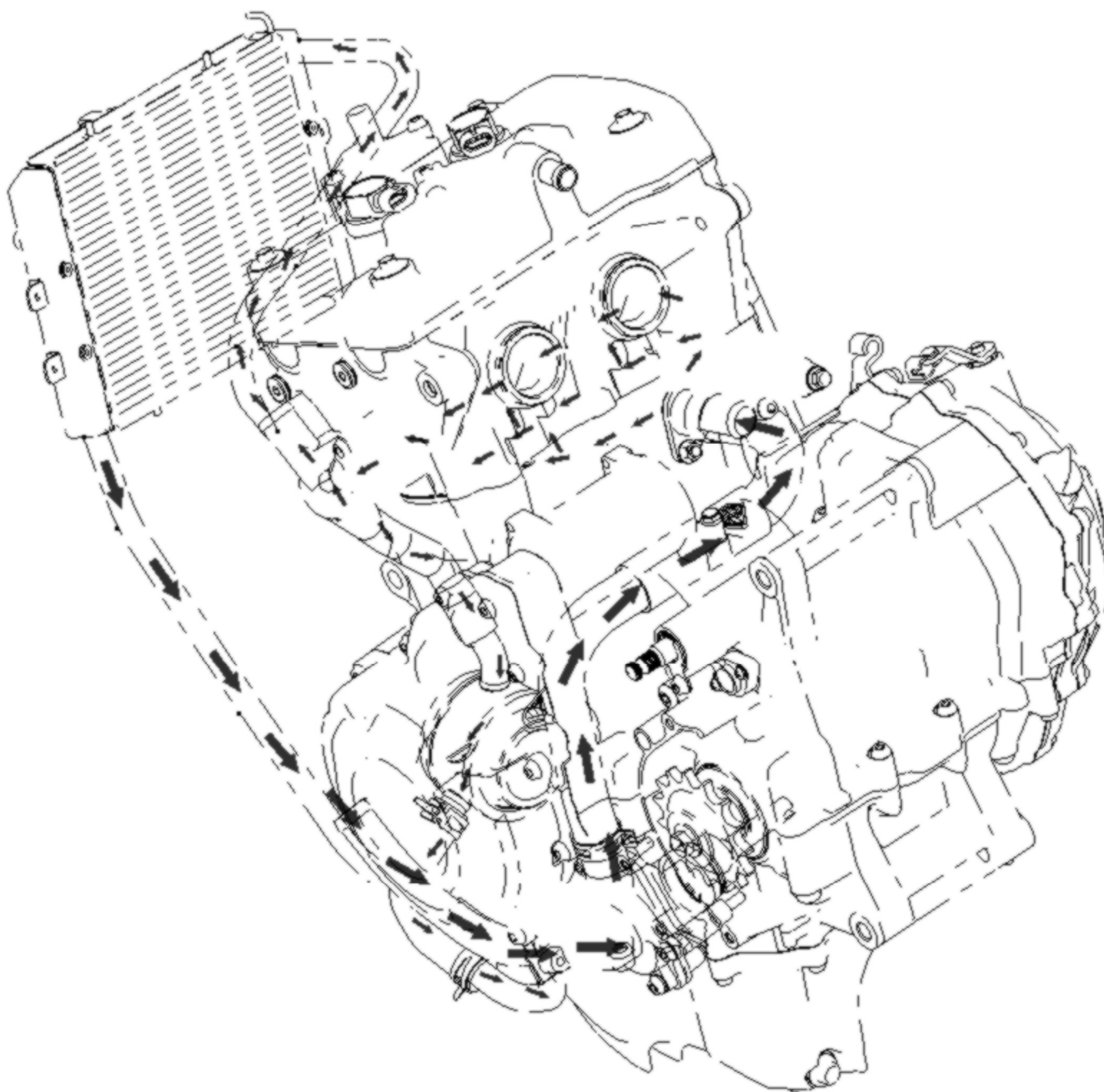

System test

Heat radiator cover/System pressure test

Remove fairing cover for right middle impeller.

Remove heat radiator cover [1]

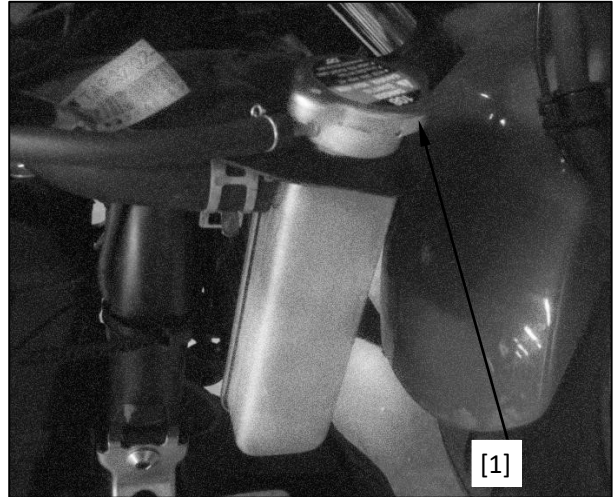

Get gasket of heat radiator cover wet, then assemble cover into testor [2].

Lay pressure on heat radiator cover by testor. .

In case the heat radiator cover fails to keep pressure, or too high or low the pressure relief, please replace it.

The heat radiator cover must bear the given pressure at least 6 seconds.

Pressure for heat radiator cover:

108-137 KPa

Connect the testor to heat radiator.

Lay pressure on heat radiator, engine and soft hose by testor to check their air

Caution:

- Overpressure may damage the cooling system, whose pressure shall not be

sealing performance.

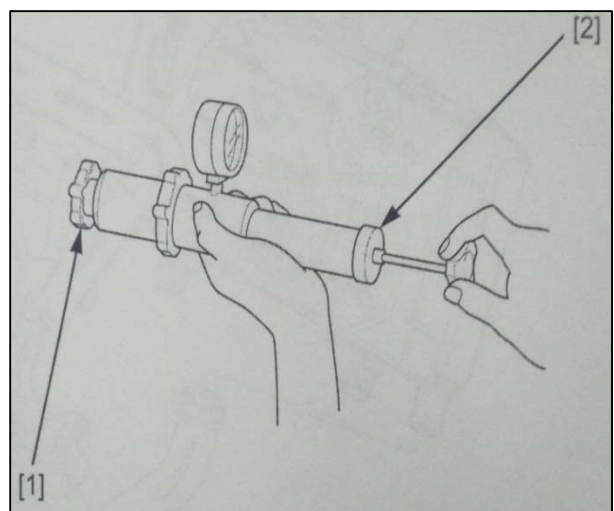

more than 137Kpa.

- In case the system fails to bearing given pressure by at least 6 seconds, please repair it or replace parts.

Coolant replacement

Coolant replacement/Air exhaust

Caution: When filling up the system or sub tank, or check the coolant level, please lay the motorcycle on horizontal ground and keep it upright, then remove fairing cover for electric fan.

Remove water drainage bolt [1] for water pump and flat washer [2].

Remove heat radiator cover [3], drain off

Remove water drainage bolt [4] and flat washer [5] on cylinder, then drain off coolant.

When new flat washer was replaced, assemble water drainage bolt.

Fasten water drainage bolt to correct torque.

Torque:

Drainage bolt for water pump: 11N.m

Drainage bolt on cylinder head: 11N.m

the coolant.

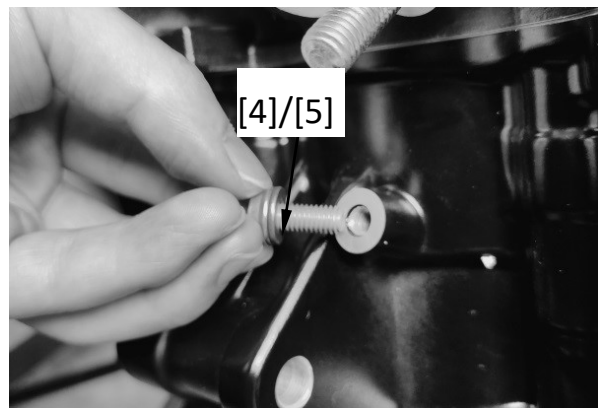
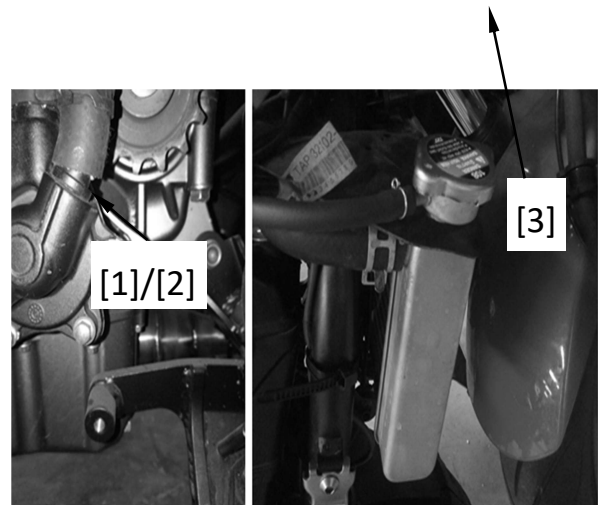

Cut off soft hose [1] for siphon from heat radiator.

Pull off siphon hose from its clamp. 。
Put soft hose on lower place out of engine rim, then drain off coolant from storage tank.

Drain off coolant, the wash the internal of storage tank by water.

Assemble soft hose into its clamp and heat
Fill up with suggested coolant through filling-up port to neck [1] of cooling system.

The coolant we suggest:

With ethanol without silicate

Standard viscosity of coolant:

Mixture with ratio of 1:1 to distilled water

Exhaust air in system according to operation below:

1. Shift the engine to neutral gear.
2. Start engine and idly run it for 2-3 minutes.
3. Start and stop throttle by 3-4 times, exhaust all air in system.
4. Stop the engine, fill up with coolant if it is necessary.
5. Assemble heat radiator cover.

Fill up storage tank with coolant we suggest.

Re-assemble fairing cover.

radiator.

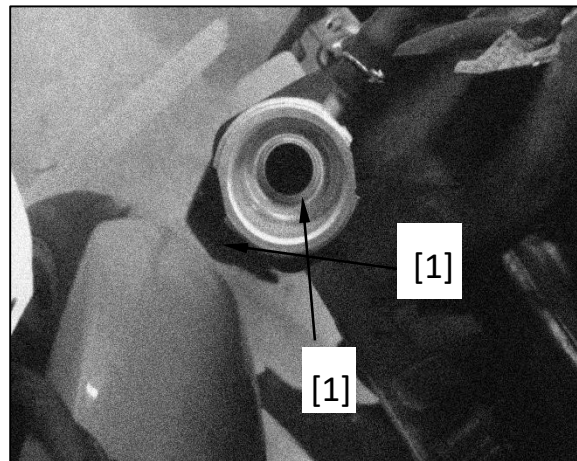

Thermostat

Disassembly/Re-assembly

Drain off coolant.

Remove bolt [1] and thermostat cover [2].

Remove thermal valve from cylinder head.

The re-assembly is precisely opposite to disassembly.

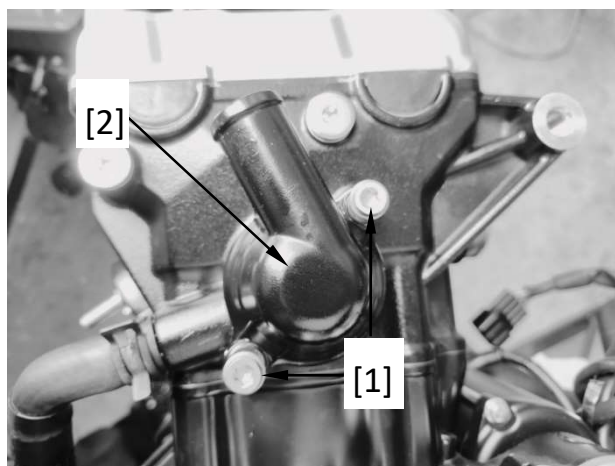

Torque:

Bolt on thermostat cover:

11N.m

Caution:

When assembling thermostat, please align it to air exhaust hole [1] and water passage groove [2] on cylinder head.

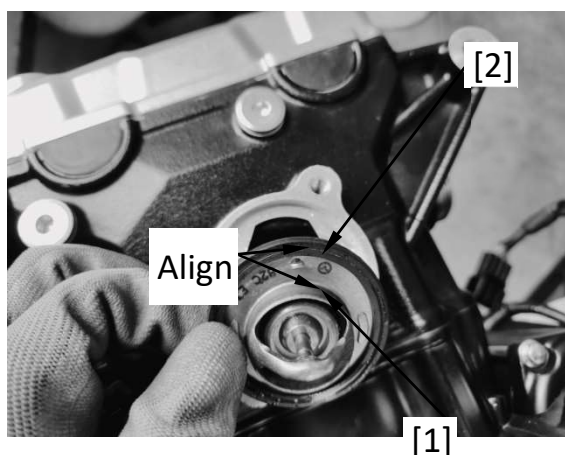

Inspection/Test

Check if there is damage of surface of thermostat [1].

In case the thermal valve is opening under room temperature, please replace.

Check and confirm if there is damage on sealing ring [2], in case it is, please replace.

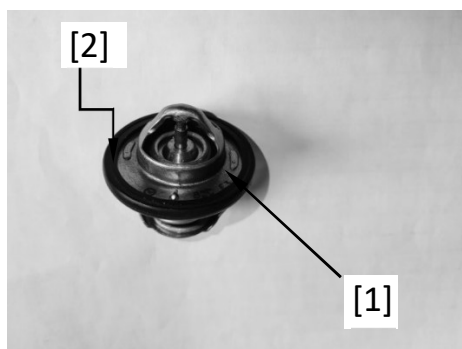

Caution:

Wear heat proof gloves and suitably protect eyes, keep combustible material far apart electrical parts.

Don't let thermostat and thermometer [1] touch bottom, otherwise the result would be wrong. Heat water to working temperature by electric furnace and keep for 5 minutes. Suspend thermostat [2] in hot water to check its performance.

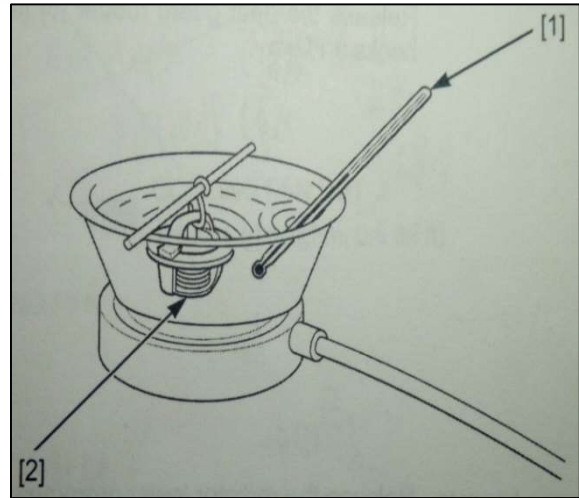

Initial temperature of thermostat:

80–84°C (176–183°F)

Complete height for valve:

At 95°C (203°F) not lower than 8mm

In case the thermostat fails to get opened under given temperature, please replace.

Water pump

Check sealing performance for end surface

Check if there is coolant leaks from overflow hole [1].

- A few coolant leaks out is normal.
- When starting engine, make sure there is not coolant leaking out.

Replace water pump for a new one if it is necessary.

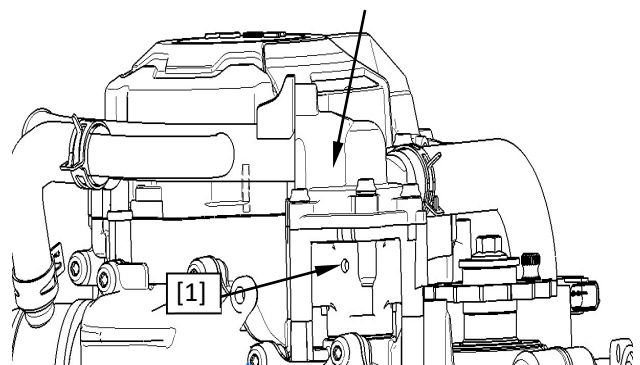

Disassembly/Re-assembly

- When removing water pump body, there will be oil flow out. When re-assembled, fill up with appointed oil to given place (Refer to corresponding chapter of lubrication system).
- Drain off coolant.
- Remove cover for driving sprocket wheel and left decorative cover.
- Put motorcycle on horizontal ground and keep upright.
- Loosen tube clamp [1], clamp [2] and bolt [3], and remove water tube [4], tube [5] and joint [6], then the
- Remove bolt [8]*2, location stud [9]*1, location stud [10]*1, water drainage bolt [11], remove seal ring [13] of water pump cover from water pump.
- Remove water pump [14] from crankcase.
- Remove seal ring [15] from water pump body.
- The re-assembly is completely opposite to disassembly.

Caution:

- Please don't break down water pump body.
- Replace all the seal rings.

seal ring between tube joint and water pump cover.

- Remove parts below: Bolt [7] for water pump cover

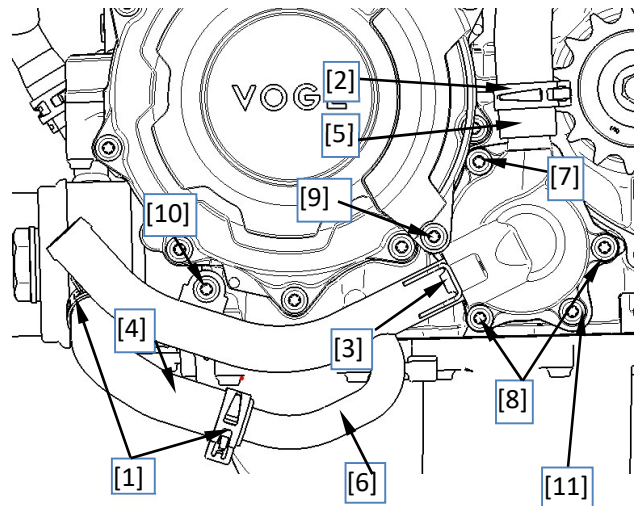

Torque: Pump mounting bolt: 11N.m

Pump cover bolt: 11N.m

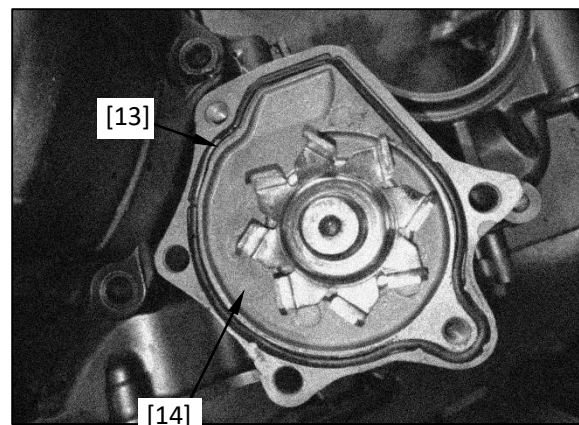

- Coat seal ring [15] of water pump body with oil.
- Please don't coat seal ring [13] of water pump cover with oil.

- *Align groove on water pump shaft to tail end of oil pump shaft by turning impeller of water pump.*
- *Check oil capacity.*
- *Fill up system and drain off coolant.*

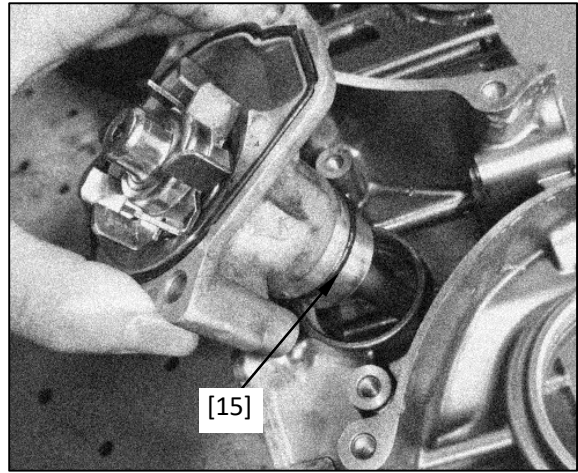

Tube joint

Disassembly/Re-assembly

Drain off coolant.

Remove throttle valve kit and air filter kit. .

Loosen tube clamp [1], then remove water intake tube [2].

Remove nut [3], tube joint [4] and o-ring [5].

The re-assembly is completely opposite to disassembly.

Caution:

- Please replace o-ring for a new one.
- Fill up system and drain off coolant.

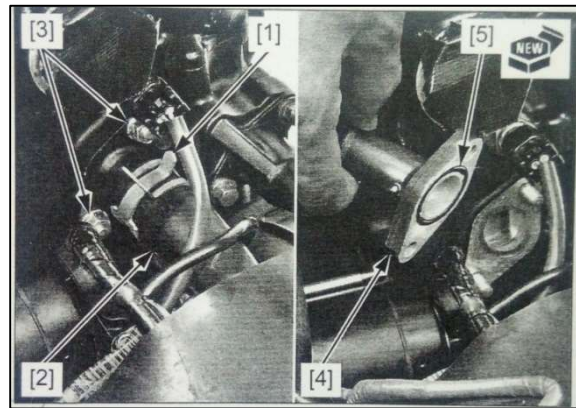

Replace stud bolt

Remove water intake tube and tube joint.

Assemble nut to 2 bolts and fasten, then screw off stud bolt by wrench.

Use new locking-up device for stud bolt.

Assemble stud bolt into cylinder body as picture shows.

When stud bolt assembled in place, please check the length from bolt head to cylinder surface is within stipulation.

Given length: 15.0mm-16.0mm

Assemble tube joint.

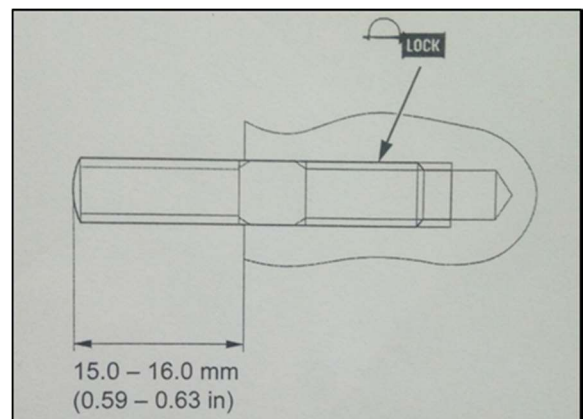

4. Lubrication system

Maintenance information

Summary

Warning

Repeatedly touch the engine oil in long time may get skin cancer, but this kind of situation is rarely to be seen, unless your skin touches the engine oil every day, but we still you suggest you wash up your hands by soap and clean water.

- When repairing the oil pump, we needn' t remove the engine from frame.
- The pre-condition for all maintenance steps in this Chapter is drain off the oil in engine.
- When disassembling and re-assembling the oil pump, please don' t let dust or dirt get into engine.
- Any part in oil pump passed the limit for maintenance, please replace the oil pump as a complete set.
- When the oil pump re-assembled, please check the oil leakage and correct oil pressure.
- Check the oil pressure indicator for engine and the EOP switch.
- Maintenance for injecting stream of piston.

Tools

Oil pressure gauge



Accessory for oil pressure gauge

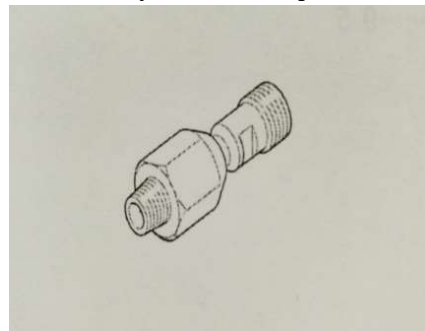

Specification for lubrication system

Unit: mm

Items		Standard	Maintenance limit
Oil capacity	After oil replaced	2.8 L	—
	When oil filter replaced	3.0 L	—
	When engine broke up	3.4 L	—
The oil we suggest		Recommended oil: SG10W-40 PI quality grade: SG or higher (Don' t adopt the one with round label of API service for energy saving) JASO T903 standard: MA Viscosity: SAE10W-40	—
Opening pressure for oil pressure sensor		Below 1200rpm/80°C: 93kpa	—
Rotor of oil pump	Clearance between tip of impeller	0.15	0.20
	Middle clearance	0.12-0.21	0.30
	Sides clearance	0.035-0.095	0.125

Troubleshooting

Too low the oil level

- Too heavy the oil consumption
- Oil leakage on external components
- Piston ring worn out or without assembling in place
- Cylinder worn out
- The seal of core shaft worn out
- Valve guiding tube worn out

Too low the oil pressure

- Too low the oil level
- Oil filtering screen was blocked up
- Oil leakage on internal components
- Incorrect use of oil

0 oil pressure

- Too low the oil level
- Safety valve for oil pressure is seized up when getting open
- Transmission chain of oil pump broke up
- Teeth of driving and driven gear of oil pump broke up
- Oil pump damaged
- Oil leakage on internal components

Too high the oil pressure

- Safety valve of oil pressure gets closed
- Oil filtering screen, oil returning hole and jet hole are blocked up
- Incorrect use of oil

Oil gets dirty

- Didn' t replace oil and filtering screen periodically
- Piston ring gets damaged

Oil emulsified

- Cylinder head cover gets expanded and cracked
- Leakage on coolant passage
- Water gets into engine

Diagram for lubrication system

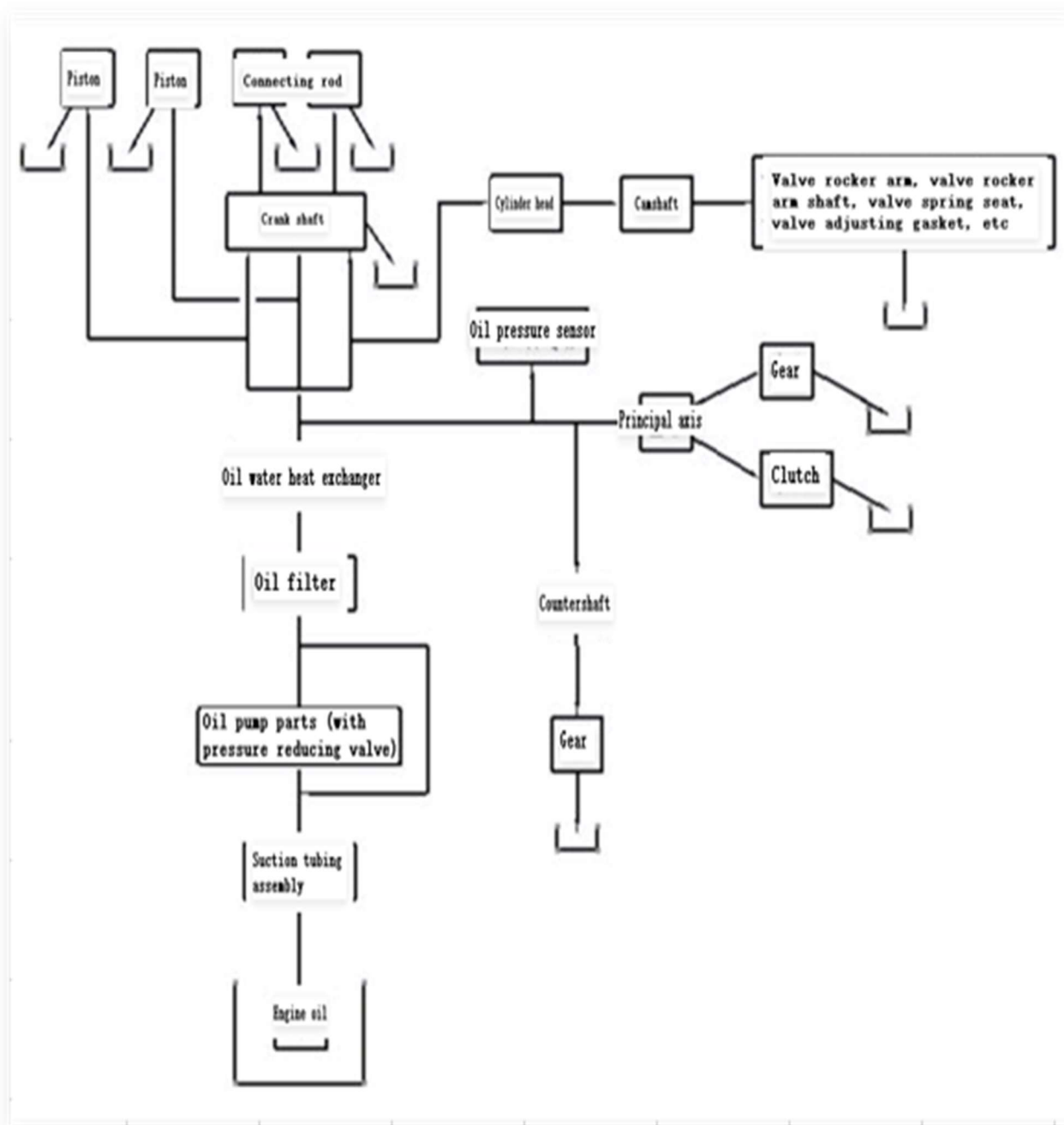

Inspection for oil pressure

Caution:

When engine is running, in case oil pressure gauge for engine keeps rising, check the gauge system before oil pressure.

Remove oil pressure sensor.

Assemble oil pressure measuring meter into main oil passage [1].

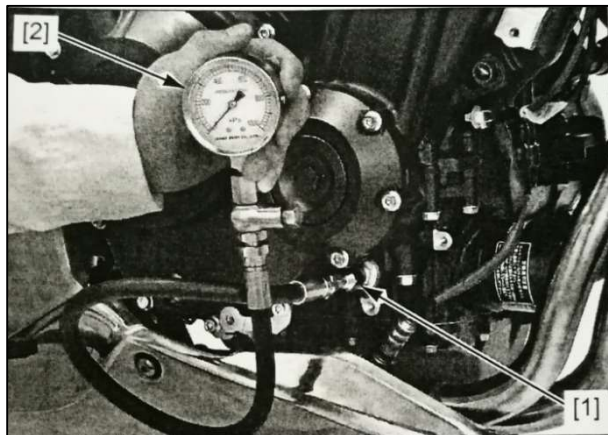

Tool:

Oil pressure gauge

Check oil level, please add some our suggested oil if it is necessary.

Heat up engine to working temperature (About 80°C/176°F), then speed up engine rotation to 1300r/min, then read oil pressure

Standard: when it is at 1300rpm/80°C, the data is: 90kPa

Stop engine and remove tools.

Assemble oil pressure sensor.

Oil pump

Disassembly/Re-assembly

Remove oil pump.

Remove bolt [1] and oil pump [2].

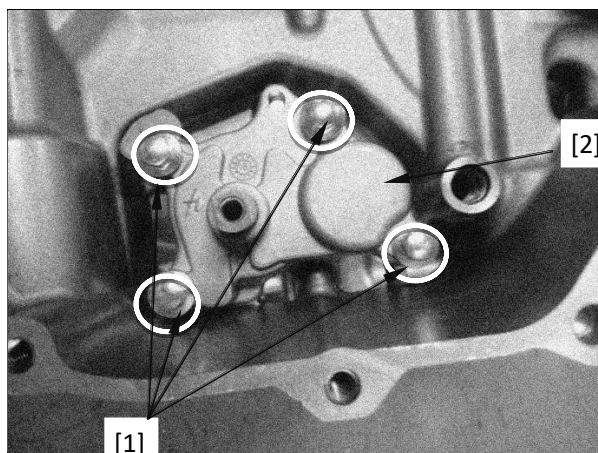

The re-assembly is completely opposite to disassembly.

Caution:

The flat side of oil pump shaft aligns to groove on water pump shaft.

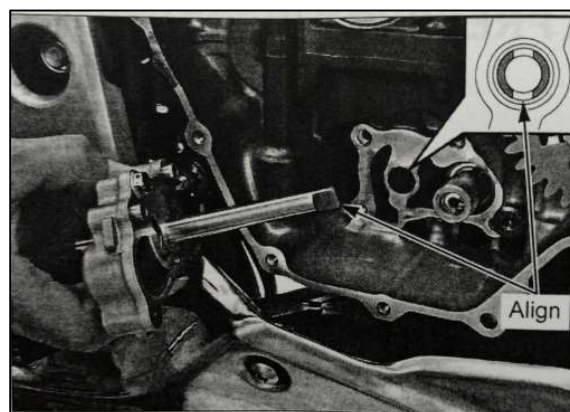

Disassembly/Re-assembly

The disassembly and re-assembly of oil pump are shown as below:

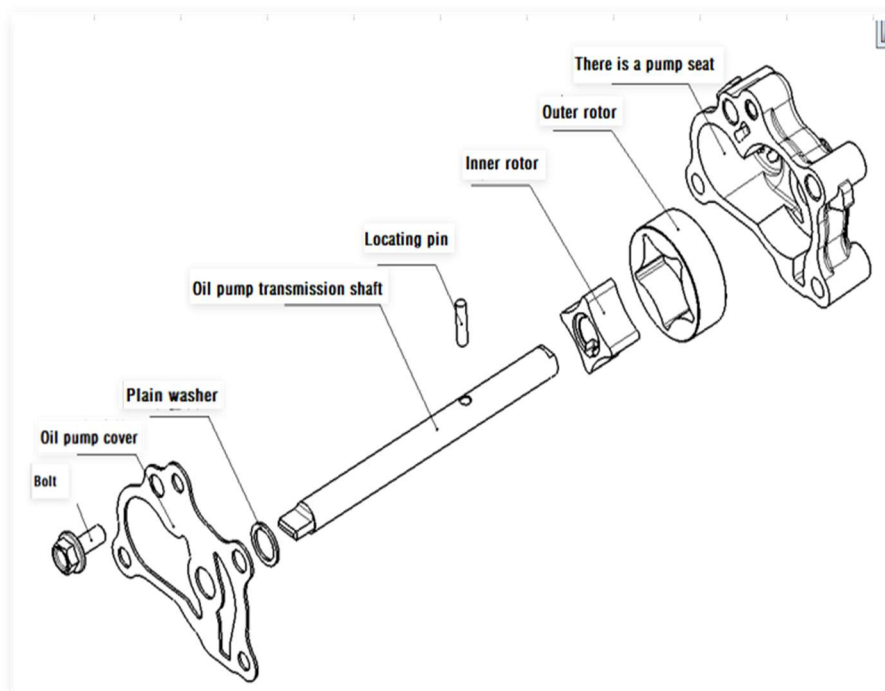

Inspection:

Check driving, driving gear and driving chain for oil pump.

Check if there is damage, wear-out, distortion or burn-out on parts below.

Oil pump shaft

Positioning pin

Internal rotor

External rotor

Oil pump base

Measure oil pumps clearance according to specification of lubrication system.

Any measured result passed maintenance limit, please replace the oil pump as a complete kit.

Pressure relief valve

Disassembly/Re-assembly

Remove oil pump.

Remove pressure relief valve [1] and o-ring [2].

Replace o-ring for a new one.

Assemble o-ring into groove on pressure relief valve.

Assemble pressure relief valve into groove on crankcase body.

Assemble oil pump.

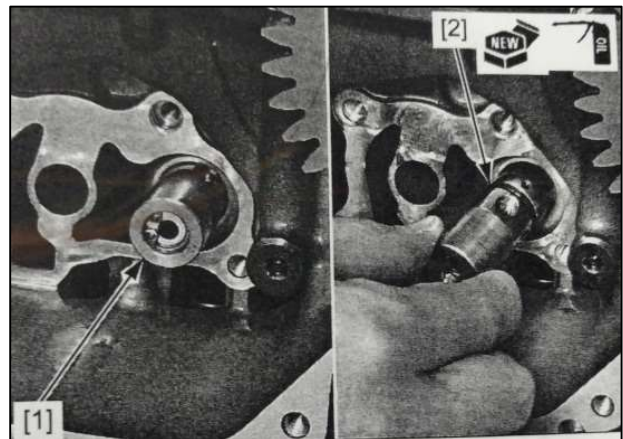

Inspection

Check normal working of pressure relief valve by pushing and pressing pushing rod [1] of controlling valve.

Remove elastic circlip [2] and break down pressure relief valve.

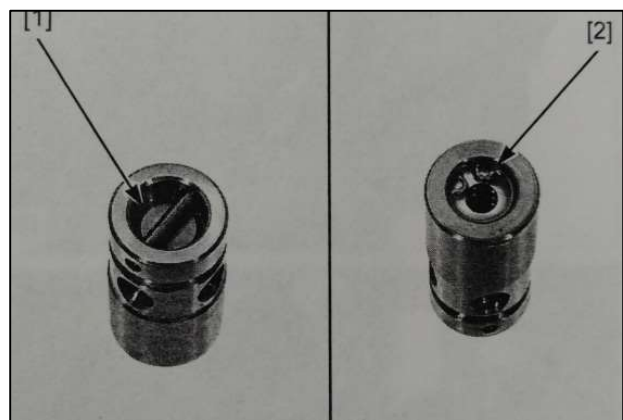

Remove elastic circlip [4], flat washer [1], spring [2] and pushing rod [3].

Check if there is wear-out, scratch or damage on pushing rod of controlling valve.

Check if there is fatigue or damage on spring.

The re-assembling sequence for pressure relief valve is opposite to disassembly.

Caution:

- *When re-assembly elastic circlip, whose chamfer angle face outwards.*

- *Make sure assemble elastic circlip into its groove.*

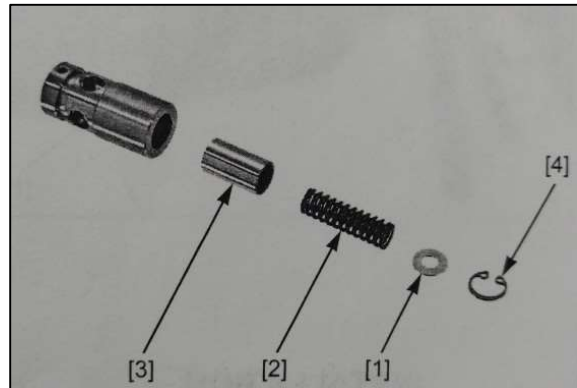

Oil absorbing tube kit

Disassembly

Remove oil drainage bolt [1] and flat washer [2], then drain off the oil.

Remove sheltering parts around it such as muffler.

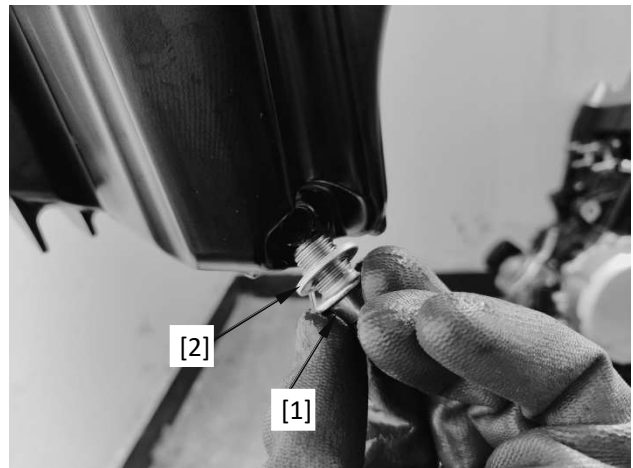

Remove bolts [1] on oil bottom case by diagonal sequence, then remove oil bottom case [2] and gasket [3].

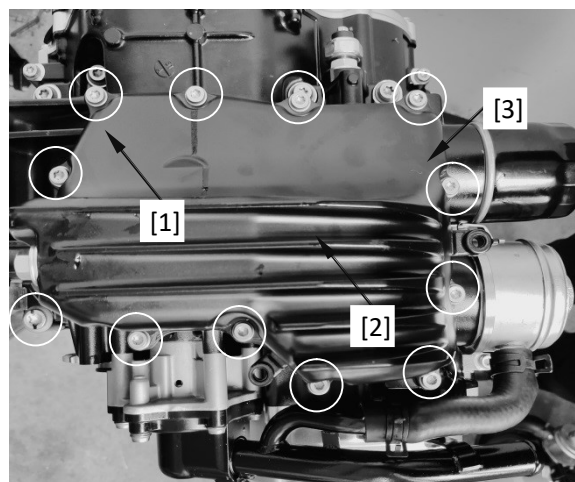

Remove oil absorbing tube kit [1] and seal ring [2].

Clean up filtering screen [3], then check if it damaged.

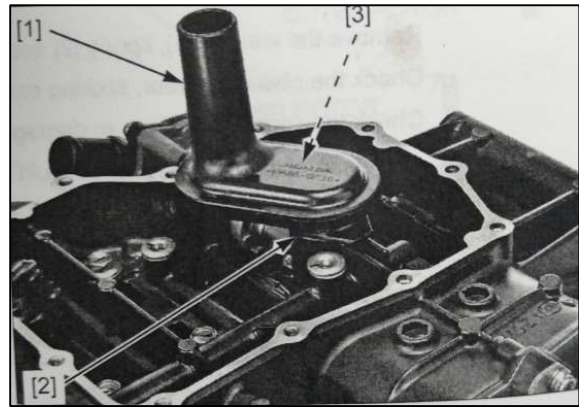

Re-assembly

Clean up residual gasket on installation surface of oil bottom case. Replace seal ring [1] for a new one, then assemble it onto oil absorbing tube kit [2].

Assemble oil absorbing tube onto crankcase.

Attention:

Align protrusion shaft on oil absorbing tube to groove on crankcase.

Replace gasket [1] for a new one and assemble it onto oil bottom case [2].

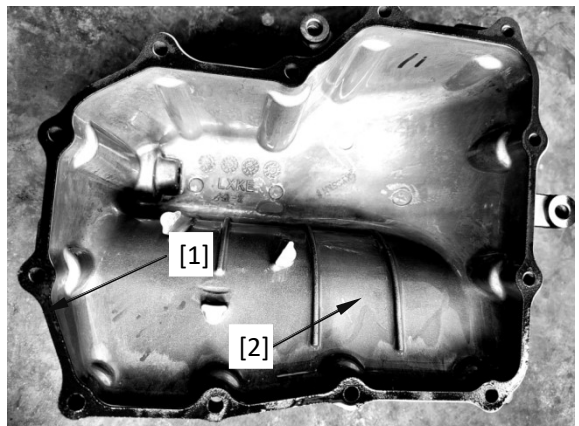
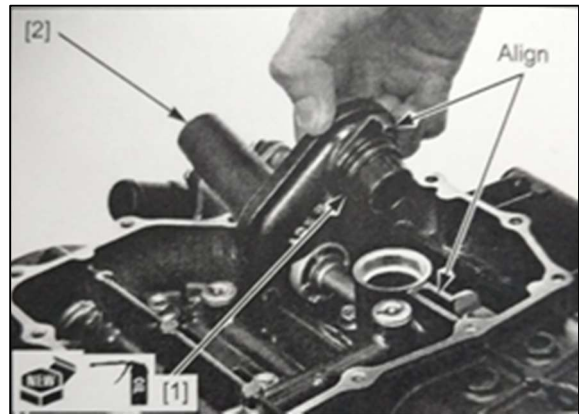

Assemble oil bottom case and bolt [3] onto crankcase body.

Fasten bolts by diagonal sequence.

Torque: 11N.m

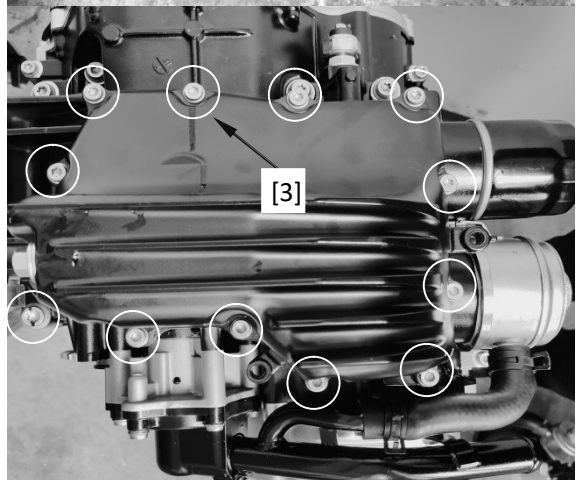

Heat exchanger for oil and water

Disassembly/Re-assembly

Drain off oil.

Drain off coolant.

Loosen tube clamp [1] and clamp [2], remove water tube [4] and [5] from heat exchanger for oil and water.

Remove bolt [6], seal ring [7] and heat exchanger.

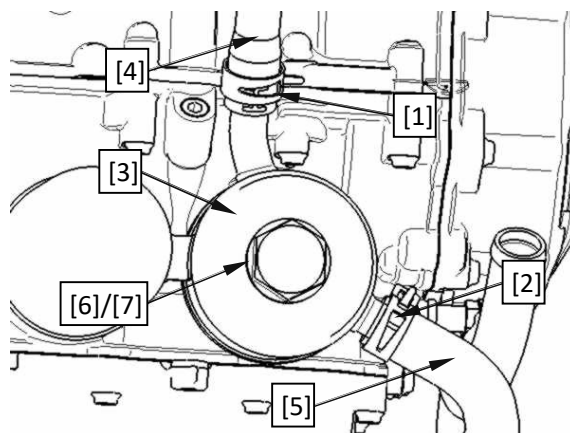

Remove o-ring [1] from exchanger.

The re-assembly is opposite to disassembly.

Coat new o-ring with oil.

Align groove on oil cooler to protrusion on crankcase.

Coat threaded part of cooler bolt and holder base of new seal ring with oil.

Torque: 59 N.m

Fill crankcase up with oil we suggested.

Fill cooling system up and exhaust all air in it.

Check if there is oil leaks.

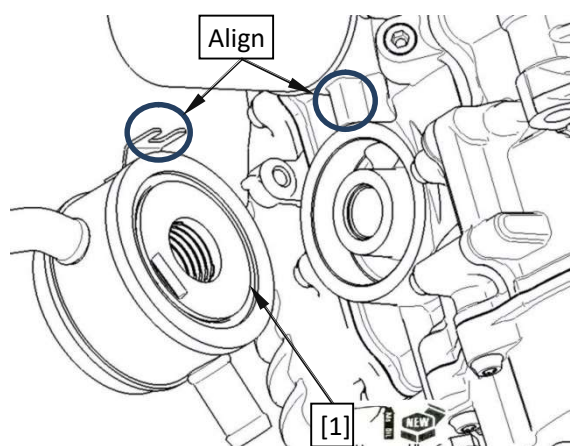

5 Cylinder head and valve

Maintenance information

Summary

- This chapter includes the inspection and maintenance for cylinder head, camshaft and swinging arm.
- When repairing the camshaft, swinging arm and adjusting stud of tensioner, we needn't remove the engine from frame; But when repairing the cylinder head and valves, we need remove the engine from frame.
- When disassembling the components, mark up the removed parts for a correct re-assembly.
- Before checking, wash up all the removed parts by cleanser, then dry them up by compressed air.
- The lubricant on camshaft is got through the oil passage in cylinder head and its cover, in this case, before re-assembling the cylinder head and its cover, wash up their oil passage first.
- Please don't damage the contact surface when disassembling the cylinder head and its cover.

Tools:

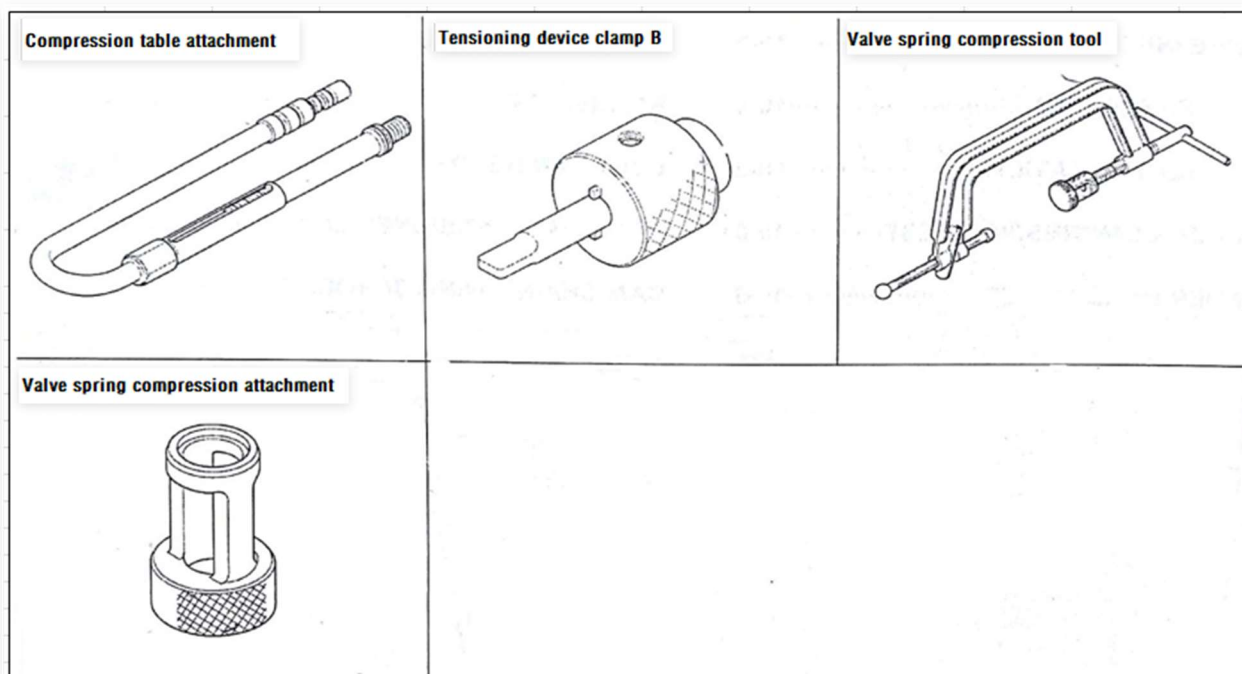

Specification for cylinder head/Valves

Unit: mm

Items		Standard	Maintenance limit
Cylinder pressure under electrical starting		$\geq 1200\text{KPa}$	—
Valve clearance		Air inlet	0.10~0.15
		Air exhaust	0.15~0.20
Swinging arm and its shaft	Internal diameter of swinging arm	Inlet/Exhaust	8.013-8.028
	External diameter of swinging arm shaft	Inlet/Exhaust	7.983-7.995
	Clearance between swinging arm and its shaft	Inlet/Exhaust	0.018-0.041
Camshaft	Protrusion height of cam	Air inlet	35.8022-35.8622
		Air exhaust	35.8019-35.8619
	Clearance between journal and hole		0.028-0.062
	Runout		—
Valve, guiding tube of valve	Valve rod's diameter	Air inlet	4.475-4.490
		Air exhaust	4.465-4.480
	Internal diameter of valve's guiding tube	Inlet/Exhaust	4.500-4.512
	Clearance between valve rod and its guiding tube	Air inlet	0.01-0.037
		Air exhaust	0.02-0.047
	Guiding tube's height	Inlet/Exhaust	12.90-13.20
	Width for gate line of base ring	Inlet/Exhaust	1.0-1.20
Free length of valve spring	Internal diameter	34.5	
	External diameter	41.85	
Flatness of cylinder head		—	0.05

Troubleshooting

- Malfunction at the top place of engine is usually bad for engine performance. We can find out these malfunctions by compression test, also we can find them by detective rod or stethoscope to know where the engine noise comes from, even can reach the top part of engine.
- In case the power output of engine is weak when it under low speed, please check if there is white smoke in beathing tube of crankcase. In case the soft hose is smoky, please check the jamming on piston ring.

When engine is working under low speed, too low the compressing pressure, difficult starting or poor performance

- Valve
 - Incorrect adjustment for valve clearance
 - Valve burned out or got bent
 - Wrong valve timing
 - The valve spring got cracked
- Cylinder head
 - The gasket of cylinder head with leakage or damage
 - Cylinder head gets bow, twist or crack
 - Spark plug is flexible
- Cylinder, piston or piston ring worn out

Compressing overpressure, overheat or cylinder knock

- Too much carbon buildup on piston head or in combustion chamber

Smoky

- Cylinder head
 - Valve rod or guiding tube worn out
 - Sealing piece for valve rod damaged
- Cylinder, piston, or piston ring worn out

Noisy

- Cylinder head
 - Incorrect adjustment for valve clearance
 - Valve gets jammed or its spring cracked
 - Camshaft worn out or damaged
 - Swinging arm and its shaft worn out
 - Swinging arm and valve rod' s end worn out
 - Chain of cam gets flexible or worn out
 - Timing chain worn out
 - Teeth of cam' s sprocket wheel worn out
- Cylinder, piston and piton ring worn out

Poor idling

- Too low the compressing pressure in cylinder

Components layout

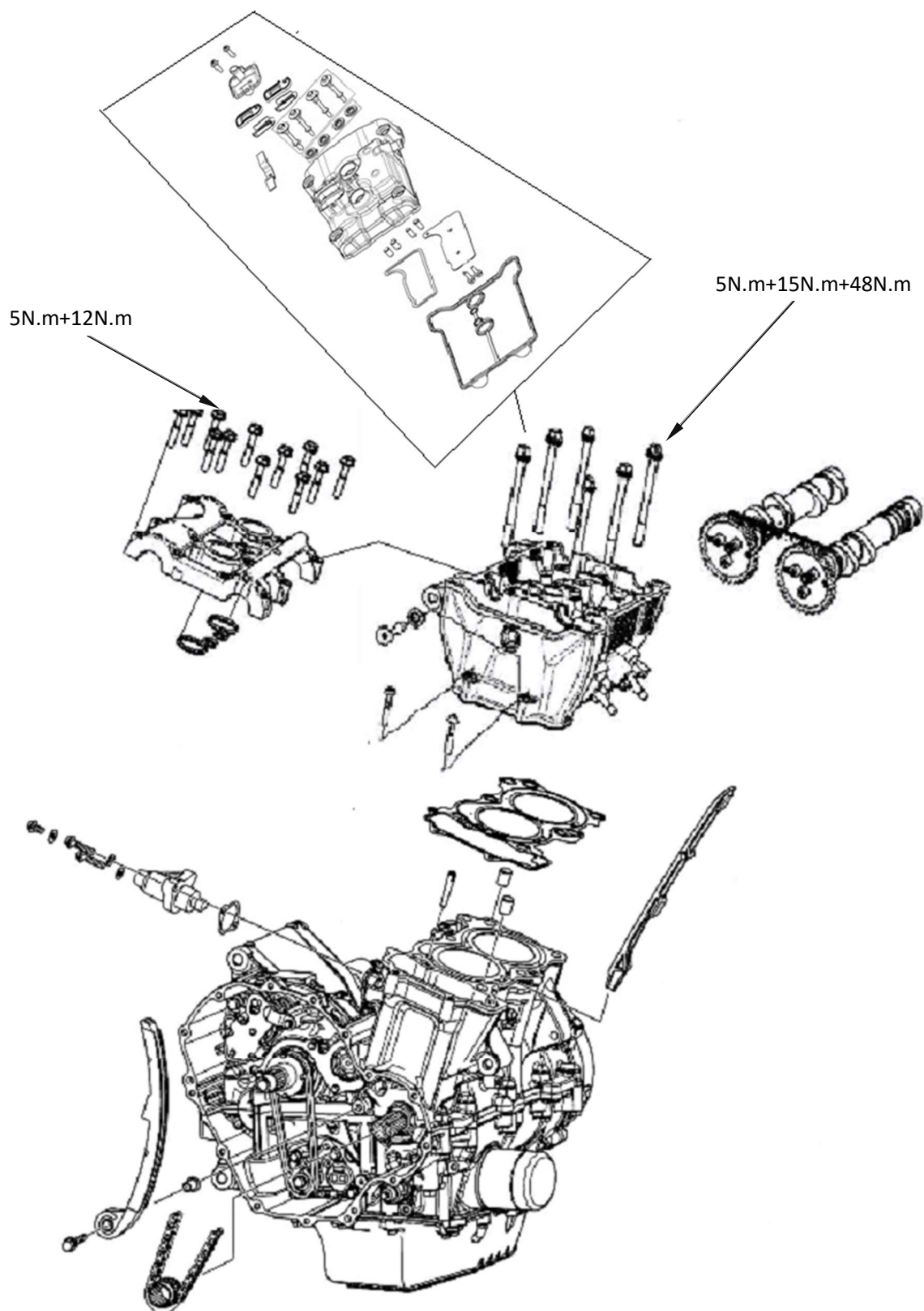

Cylinder compression test

Heat up engine to working temperature.
Stop engine and remove spark plug.
Temporarily assemble wire of ECM to 33(Black) connector.

Assemble threaded end of cylinder pressure gauge [1] into hole of spark plug.

Tool:

[2] Pressure gauge accessories.

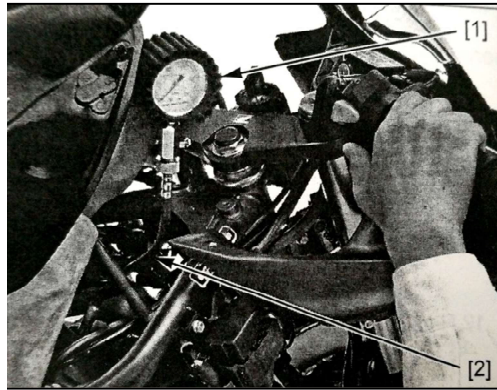

Turn the ignition switch to “ON”, then turn engine to “ \curvearrowright ”.

Shift gear position to neutral.

Keep full throttle, start engine until data on pressure gauge stopped rising.

The highest data may usually keep for 4-7 seconds.

Compression pressure:

At 450rpm, not less than 1200KPa

Analysis for low pressure:

- Leakage at cylinder head gasket.
- Improper valve clearance adjustment
- Valve leaks
- Piston ring or cylinder wear out

Analysis for high pressure:

- Carbon buildup in combustion chamber or piston top.

Cylinder head cover

Disassembly/Re-assembly

Caution:

Repair cylinder head cover needn' t

remove engine from frame.

Remove fuel tank under holder.

Remove parts below:

- Remove plug [1] for secondary air supplemt valve
- Remove secondary air suppelementary tube[2]
- Remove breathing tube [3]

Fuel evaporation control system [4] [5]

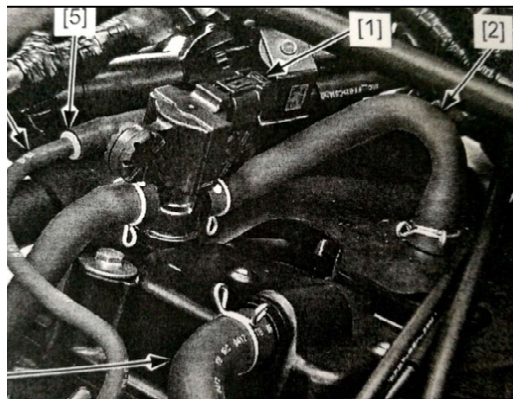

- Remove bolt [1], locating plate for clutch cable, then remove the cable [4] from its lug [3]. Remove clutch cable from frame.

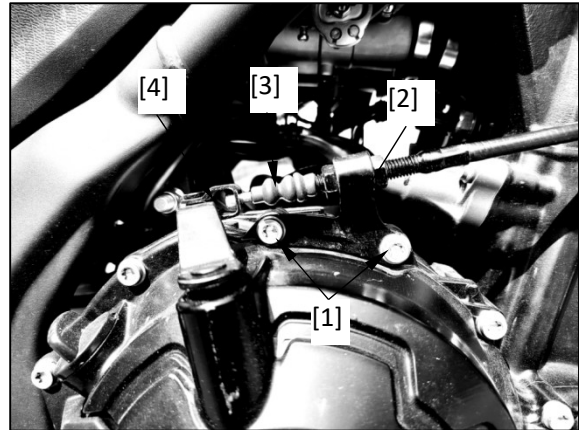

- Loosen locking nut A [1] from adjustor of throttle cable and the adjustor itself [2], then loosen and remove throttle cable A [3] from throttle drum and cable bracket.

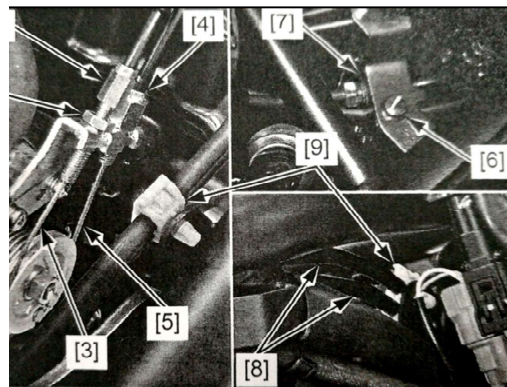

- Loosen adjustor B [4] for throttle cable, then loosen and remove cable [5] from throttle drum and cable bracket, Remove throttle cable from frame.

- Remove bolt [6] and wire joint [7] for braking.
- Remove brake tube [9] from 2 wire clips [8], then remove the clips from frame.

- Fuel evaporation system: Remove installation bolt [1] of carbon canister and washer [2], then remove the carbon canister [3].

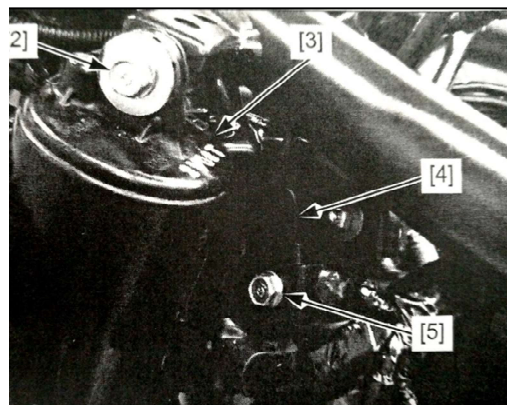

- Remove bolt [4] and connective wire [5].

- Fuel evaporation system: Remove controlling solenoid valve for evaporation and emission from frame

- Loosen overflow tube [2] from tube clamp [1].
- Remove rubber plate [3] at place of overflow tube, then put it on the right side of frame.

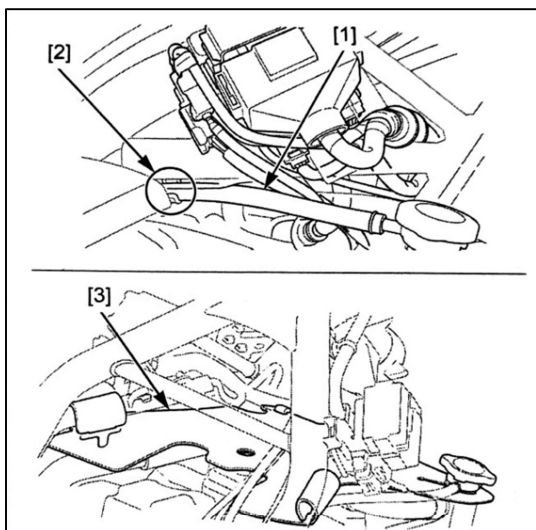

Remove bolt [1] for pressing late of ignition coil, then remove the plate [2] and ignition coil [3].

Remove cylinder head cover [4] from cylinder head.

Caution:

Forcedly remove positioning pin from cylinder head cover is not allowed.

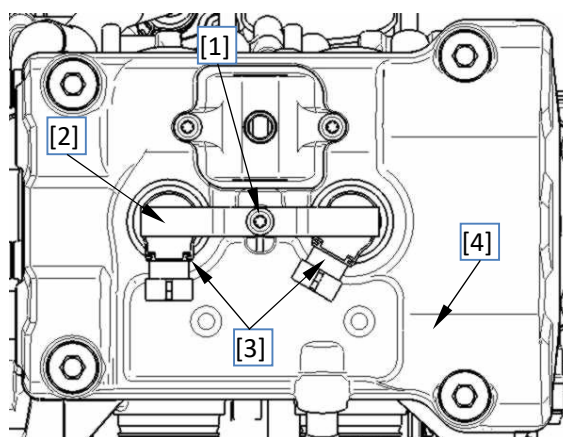

Remove seal ring [1] from cylinder head cover.

The re-assembly is precisely opposite to disassembly.

Torque: Bolt for cylinder head cover: 11N.m

Bolt on right crankcase: 11N.m

Caution:

- *Replace seal ring of cylinder head for a new one.*
- *When re-assembling, please assemble seal ring of cylinder head cover into groove on it, then coat round chamfer with protrusion with sealant 1596.。*

Please adjust the below:

- Free play for throttle cable
- Free play for clutch lever

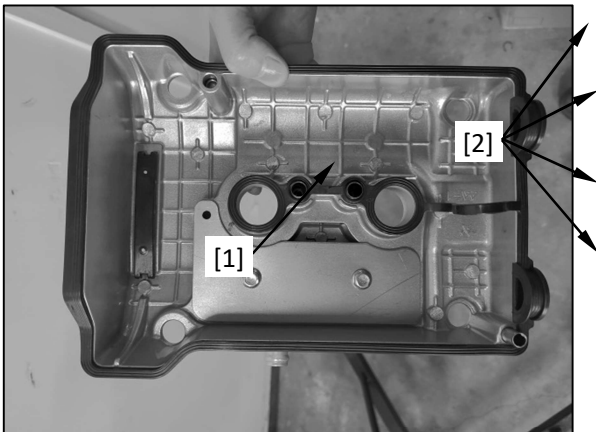

Camshaft

Caution:

- *When repairing camshaft, it needn' t remove engine from frame.*

Remove cylinder head cover.

Make sure the piston of cylinder 1st is at upper stopping point of compression stroke.

Remove seal bolt [1] and washer [2].

Turn adjustable stud for tensioner clockwise and backwards completely by special tools.

Tool:

[3] Tensioner fixture B

Caution:

To avoid damage on cylinder head, camshaft and its bracket, please loosen bolts [1] on camshaft bracket by referring number 12-1 on camshaft, and please don' t let bolt drop into crankcase.

Remove camshaft bracket [2] and positioning pin from cylinder head [2] 及定位销。

Please don' t forcedly remove positioning pin from bracket of camshaft.

Suspend chain of cam by line to prevent it dropping into crankcase.

Move chain [1] away from sprocket wheel, then remove camshaft [2].

Lift up 8 pieces of valve swinging arm [1].

Remove 8 pieces of adjustable washer [2] for valves.

Caution:

- *Please don' t let adjusting shim drop into crankcase.*
- *Mark up adjustive shim for a correct re-assembly.*
- *Take out shim by tweezers or magnet would be easier.*

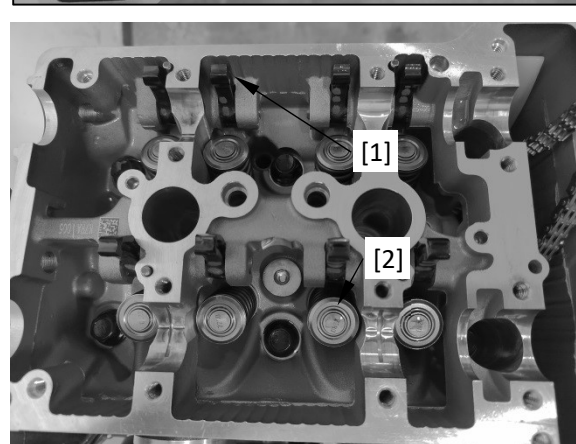
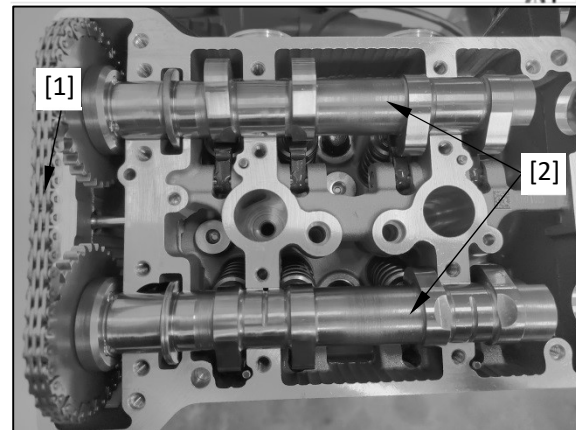
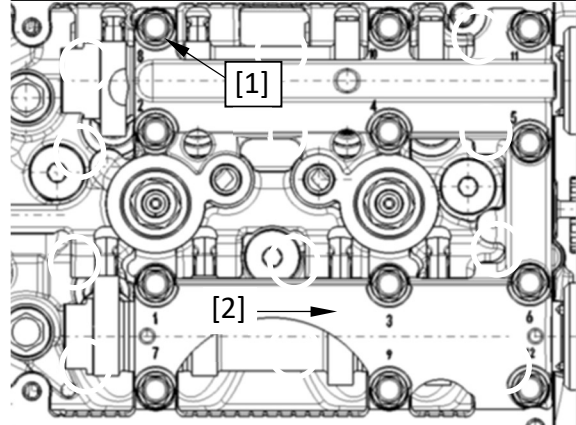
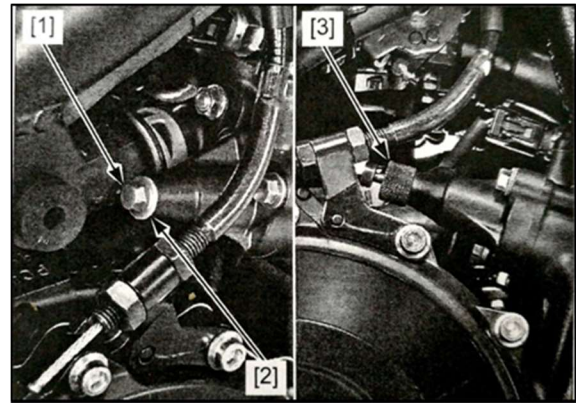



Inspection

Check and confirm if there is damage, wear-out, distortion, burn-out or oil passage

blocking up on parts below.

- Sprocket wheel of cam/camshaft
- Camshaft bracket/Positioning pin
- Pressure plate for chain of cam

Measure each part according to specifications of cylinder head/valves.

Camshaft runout

Fix both ends of camshaft by V-shaped piece, then measure its runout by micrometer.

Maintenance limit: 0.04mm

Wipe up oil on camshaft, its bracket and cylinder head.

Assemble camshaft onto cylinder head.

- Align mark “EX” on sprocket wheel [1] to mark line [2] in picture on right, meanwhile make sure camshaft is stably laid.
- Basically align mark “IN” on air exhaust camshaft [3] and mark line [4] in picture on right, meanwhile make sure camshaft is staly laid.
- Vertically put a gap gauge [1] of plastic line on the top of journal

Caution:

During inspection, please don' t turn the camshaft.

Make sure positioning pin of camshaft bracket aligned to pin' s hole on cylinder head. Assemble camshaft bracket on cylinder head.

Bolt for camshaft bracket: Bolt M6×28mm

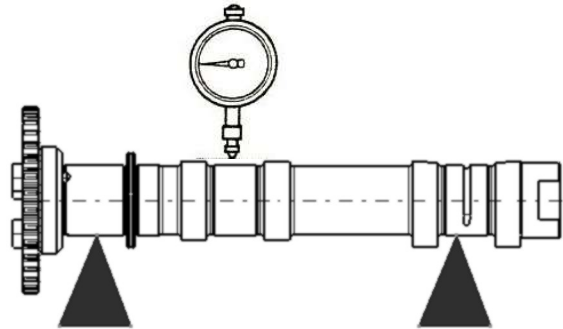

of camshaft, please get it bypassing of oil hole.

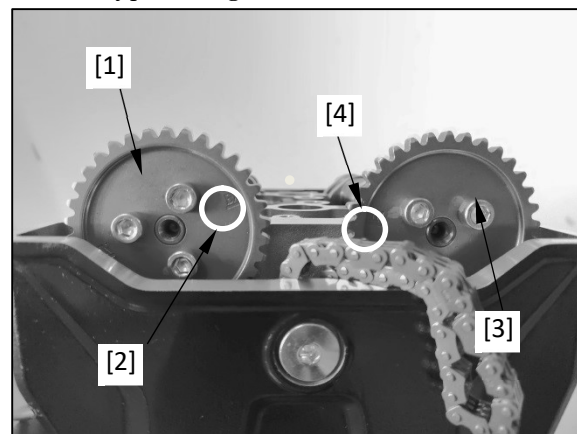

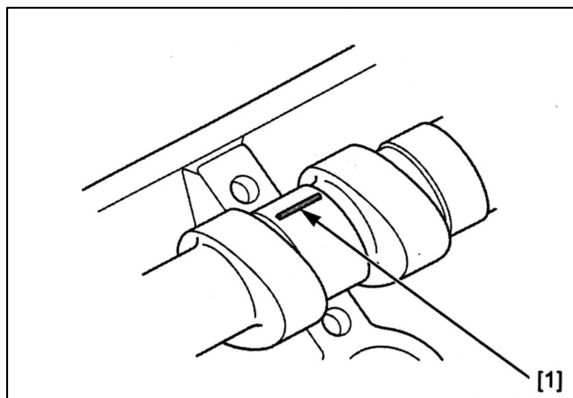

Caution:

Fasten bolts by 2 steps according to sequence number on camshaft bracket of 1→12.

Torque: 5N.m+12N.m.

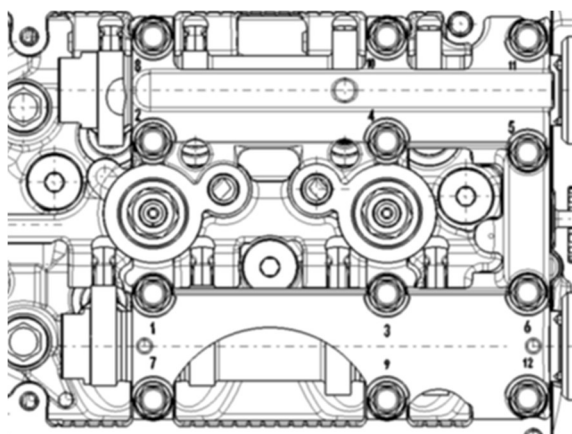

Remove camshaft bracket, then measure each width for gap gauge of plastic line. The widest place is the oil clearance.

Maintenance limit: 0.10mm

When it passed maintenance limit, replace the camshaft for a new one and measure oil clearance once again.

In case the oil clearance passed maintenance limit, replace the camshaft bracket and cylinder as a complete kit.

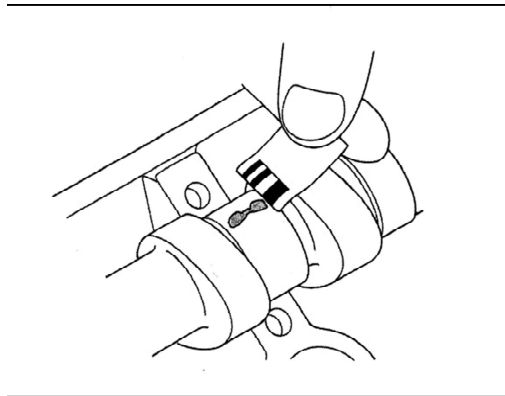

Re-assembly

Caution: When turning the crankshaft, please don't press-fit chain of cam into timing sprocket wheel.

Turn crankshaft clockwise, align mark "T1" on primary driving gear to index mark [2] on right crankcase cover.

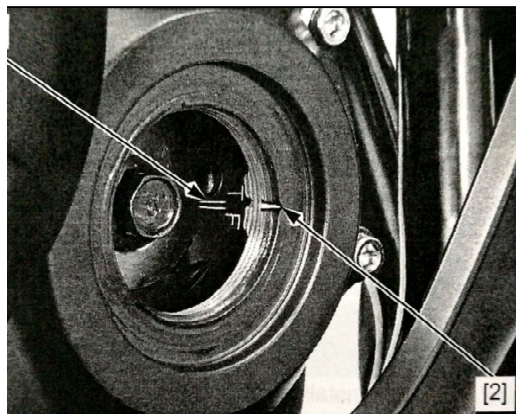

Caution: Please don't let adjustive shim for valve drop into crankcase.

Assemble adjustive shim [1] for valve back to original place on base ring of valve in turn.

Lay down swinging arm shaft [2].

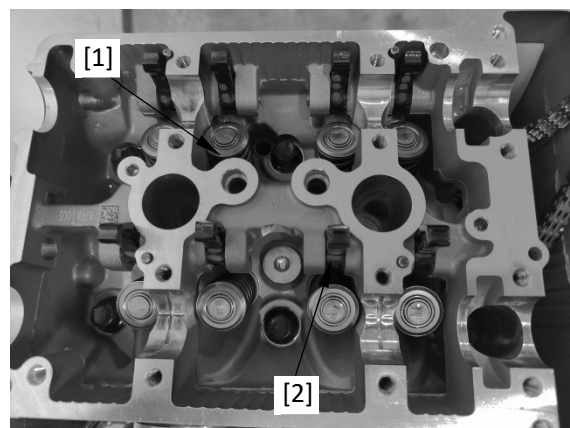

Identification sign on camshaft for air intake and exhaust:

There is groove mark [1] on axial and limit round plate for exhaust camshaft

while there isn't the one on that if air intake.

Coat cam, journal and other stress surface of camshaft [1] with molybdenum disulfide solvent.

Coat all the surface of chain [2] of cam with oil.

Assemble chain and sprocket wheel of cam, then assemble camshaft on cylinder head.

Align mark [3] "IN" on sprocket wheel to lower line of mark [4] "EX" on cylinder head as picture shows.

Make sure positioning pin on camshaft bracket to their hole on cylinder head.

Caution:

Coat bolt line for camshaft bracket and seal surface with oil.

The specification of bolt for camshaft bracket and their fastening please refer to former description.

Remove tensioner [1] from its adjustive stud.

Turn crankshaft clockwise for times, the align mark "T1" on primary driving gear to index mark on right crankcase cover.

Check timing of valve once again.

Check valve clearance.

Assemble seal bolt [2] and replace gasket [3] for a new one.

Assemble cylinder head cover.

Caution:

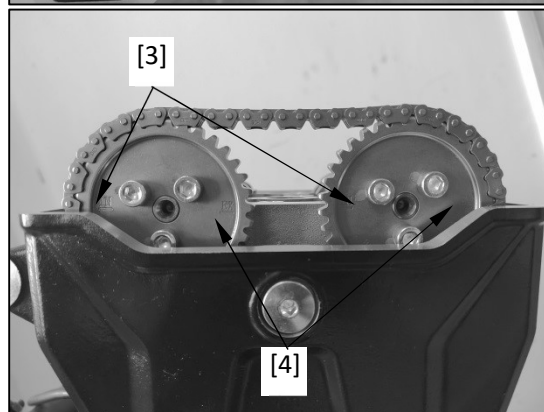
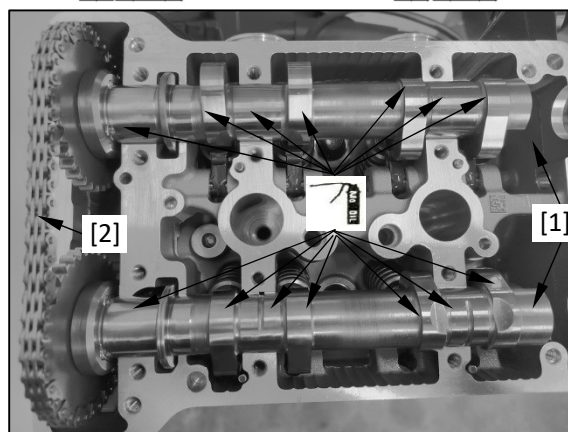
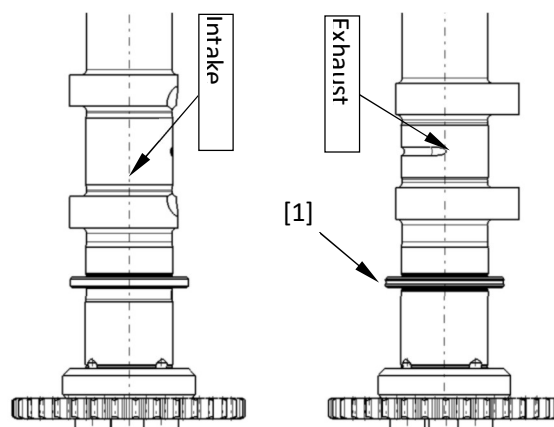

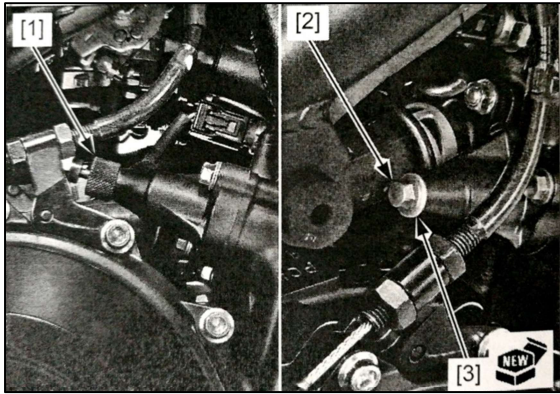

Before assembling cylinder head cover, check if pressing plate [1] for timing chain already assembled in place.

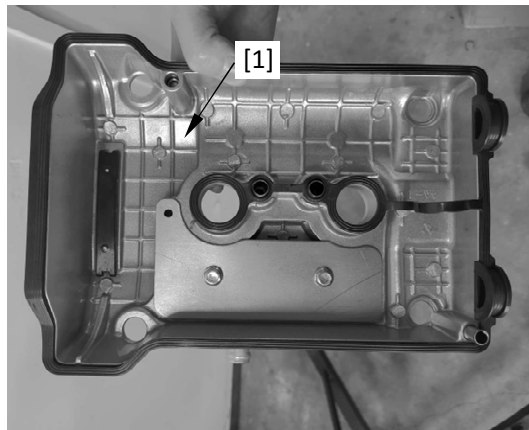

Swinging arm

Disassembly/Re-assembly

Caution:

- *When repairing swinging arm shaft, it needn' t remove engine from frame.*
- *The steps for repairing swinging arm shaft for both air intake and exhaust valve are the same.*

Remove camshaft.

Remove installation bolt [1] for swinging arm shaft of valve and gasket [2].

Remove positioning pin [1] for swingingarm shaft of valve.

Suck out swinging arm shaft [2] and the arm [3] by magnetic bar.

Coat the sliding area, stress surface and external surface of swinging arm shaft with solution of molybdenum disulfide.

The re-assembly for swinging arm and its shaft is opposite to disassembly.

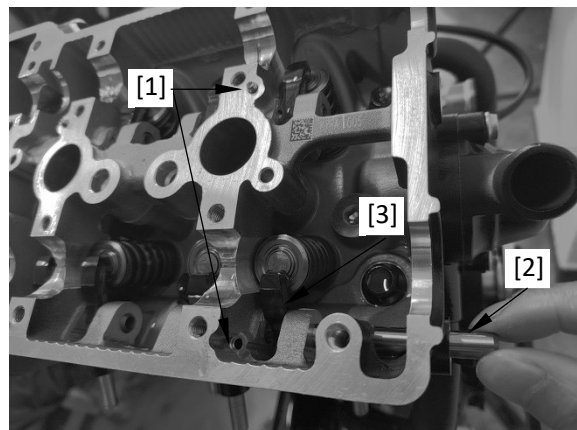
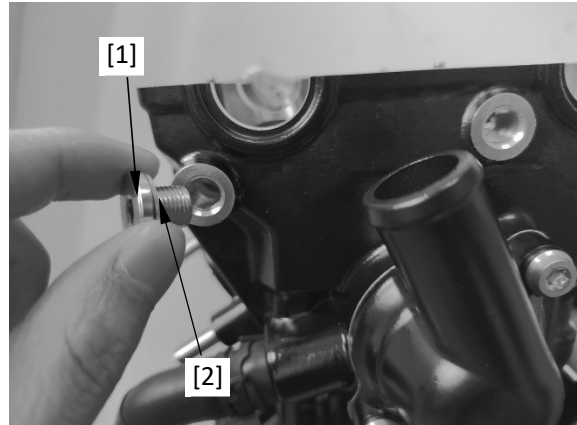

Assemble installation bolt [1] for swinging arm shaft of valve and gasket [2].

Caution:

Replace gasket for a new one.

Torque for bolt: **16N.m**

Assemble camshaft.

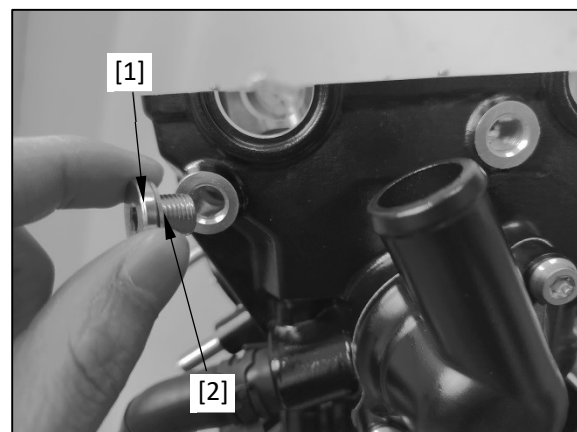

Inspection

Check if there is damage, wear-out, distortion or burn-out on parts below.

- Swinging arm

- Swinging arm shaft

Measure each part and their clearance according to specification of cylinder head/valves. Any parts passed maintenance

limit, please replace.

Cylinder head

Removal

Please remove the parts below in turn:

- Engine
- Swinging arm
- Thermostat

Loosen tube clamp [1] and remove soft hose [2] for heat exchanger between oil and water.

Remove bolt M6 [1].

Before removing bolt, suck out oil on bolt groove of 9mm on cylinder head.

Loosen bolt [2] on cylinder head of 9mm by 2-3 times, then remove bolt.

Remove silent bolt and shim [3] on cylinder head.

Remove cylinder head [4].

Caution:

Suspend chain of cam by line to avoid dropping into crankcase.

Heavily knock cylinder head is not allowed, please don't damage contact surface by any tools for prying up.

Please remove positioning pin [1] and gasket [2].

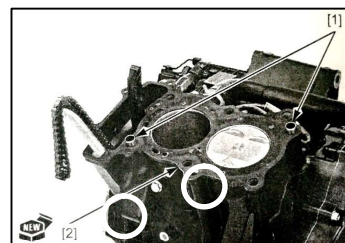
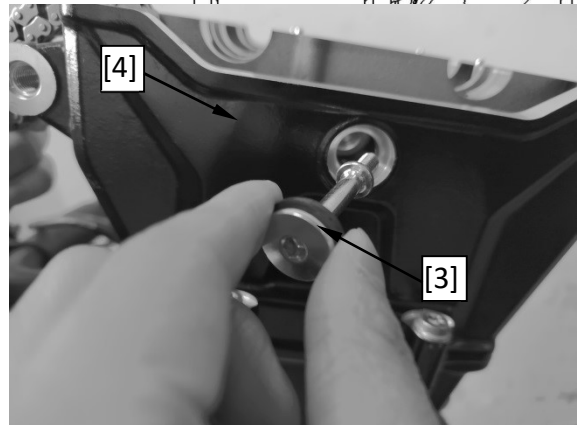
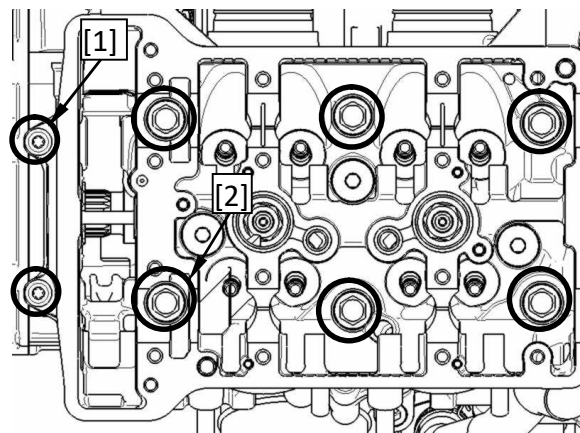
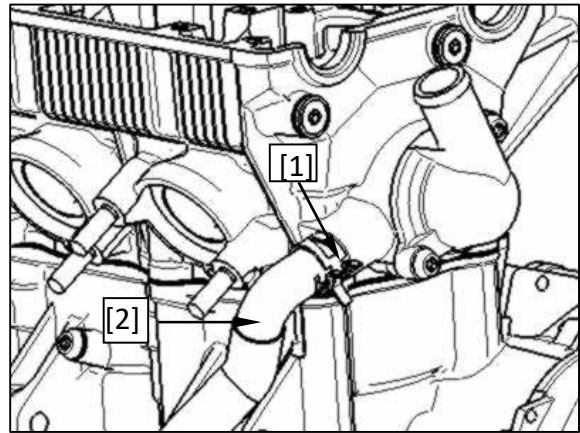

Remove guiding plate [1] of chain.

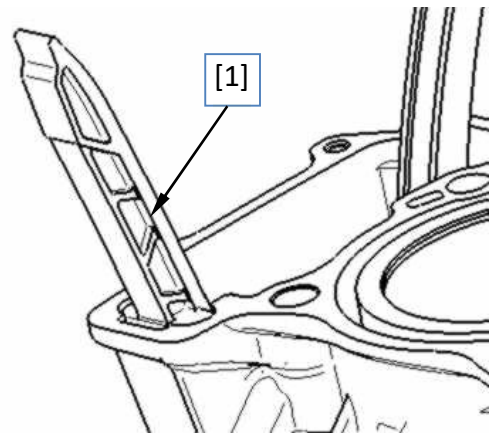

Remove rubber bar [1] for water-proof.
Check if ther bar got bad or damaged.

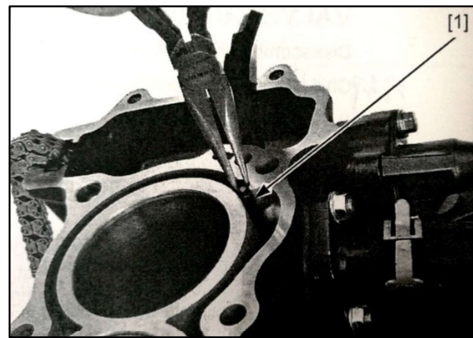

Disassembly

Remove the parts below:

- Spark plug
- Water temperature sensor

Caution:

To avoid permanent distortion on valve spring, please don't heavily press spring when disassembling it.

Remove valve clip [1] by tools for it only.

Tool:

Compression tool [2] for valve spring

Please mark up each parts when disassembling for a correct re-assembly.

Remove compression tool for valve spring and parts below:

- Spring base ring [1] for upper valve
- Outer valve spring [2]
- Inner valve spring [3]

Clean up carbon buildup in combustion chamber [7] and that on gasket surface of cylinder head.

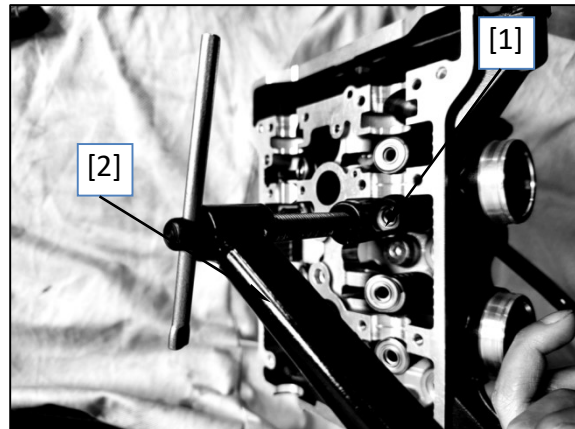

- Valve [4]
- Oil shield cover [5]
- Spring base [6] for lower valve

Caution:

Please don't damage contact surface of cylinder body and that of valve base.

Inspection

Check if there is damage, wear-out, distortion, burn-out or oil passage blocking on parts below.

- Cylinder head
- Outer and inner spring
- Valve
 - Guiding tube of valve

Measure each part and clearance according to specification of cylinder head/valve. Any part passed maintenance limit, please replace.

Clean up carbon buildup inside guiding tube by reamer before measuring.

Please refer to inspection for valve base.

Replacement for guiding tube of valve

Break down cylinder head

Put new guiding tube of valve in freezer for an hour.

Caution:

- *Please wear heat insulation glove for avoid scald when operating hot cylinder head.*
- *Please don't heat cylinder head by fire, otherwise it may distort.*

Heat cylinder head to 130-140°C by hot plate or baking oven. Ensure the suitable temperature for heating cylinder head by thermal indicating bar, which could be bought from shop for welding tools.

Hold cylinder head, push guiding tube and its clamp out of cylinder head from side of combustion chamber.

Tool:

Driver for valve guiding tube: 4.5mm

Slide main shaft on upper crankcase body and then remove its bearing on the right.

[2]Driving for valve guiding tube adjustment

Stipulation: In/Exhaust:12.90-13.20mm

Take new guiding tube [1] of valve from freezer.

When cylinder head is still hot, assemble new guiding tube from side of camshaft, until its exposing length reached stipulation.

Tool:

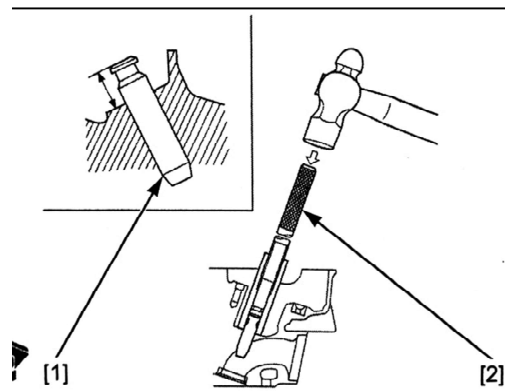

Requirement for re-assembly:

Mark up depth for guiding tube by marker pen.

Adjust depth to correct by driver of guiding tube.

Get cylinder head cooled down to room temperature.

Adjust new guiding tube by reamer when re-assembled.

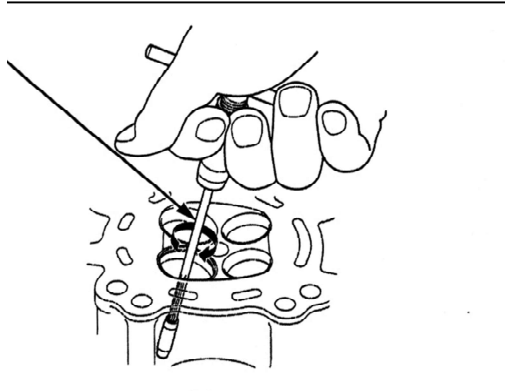

Caution:

When reamer is working, please don't let it raise up or get inclining inside of guiding tube.

During this operation, please use lubricant for cutting.

Insert reamer from side of combustion chamber of cylinder and always turn the reamer clockwise.。

Tool:

Reamer for valve guiding tube, 4.5mm

Totally clean up cylinder head to erase metallic chips after reamer worked, then

trim the valve base.

Inspection and trim for valve base

Inspection

Break down cylinder head.

Totally clean up carbon buildup for air intake/exhaust valve.

Coat each valve with a thin layer of iron-blue, slightly knock valve by hand grinding tools [1] to direction of valve base, check contact situation of valve base without turning valve.

Remove valve to check width for each surface of valve base.

The width of contact surface for valve base shall be within stipulation, while surrounding of valve base shall be smooth and flat.

Standard: 1.00-1.20mm

Maintenance limit: 1.5mm

In case the width of valve base is out of given range, please trim it. .

Grinding for valves are not allowed. In case contact surface is burned out or worn

out, or the base is not flat and smooth, please replace the valve.

Check if there is situation for base surface for valve below:

- Contact surface for valve base is not smooth or flat
 - Bent or folded valve rod, replace valve for a new one and trim its

base.

- Base surface wear-out
 - Replace valve and trim its base.
- Contact area (Too high or low)
 - Replace valve base for a new one.

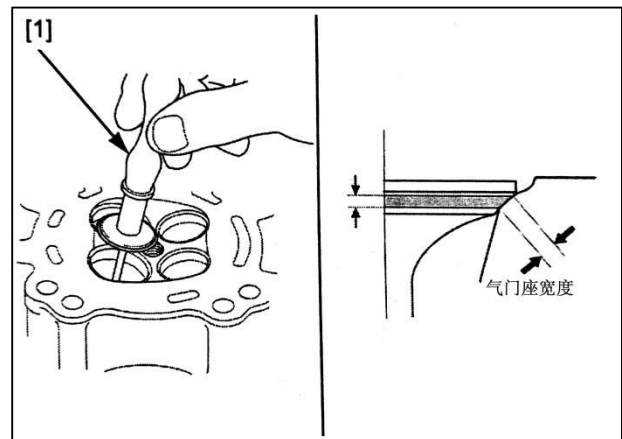

Trim

Tools for trimming valve base are as below.

Tools:

Cutter bar holder, 4.5mm

Valve base trimming cutter, 31mm (IN, 45°)

Valve base trimming cutter, 27mm (EX, 45°)

Flat milling cutter, 34mm (IN, 32°)

Flat milling cutter, 27mm (EX, 32°)

Internal milling cutter, 30mm (IN, 60°)

Internal milling cutter, 26mm (EX, 60°)

Valve base width: 1.00–1.20mm

- Please strictly follow requirement of User Manual of polisher manufacturer.
 - Please don't grind valve base too much and produce too many chips.
1. Use cutter of 45°, cut off rough place and irregular part of valve.
 2. Then use flat milling cutter of 32°, cut off ring belt area by 1/4 on upper part of working surface of valve base.
 3. Then use internal milling cutter of 60°, cut off ring belt area by 1/4 for ring belt on bottom part of w of valve base
 4. Then use trimming cutter of 45°, grind valve base to suitable width.
 5. Make sure all the rough and irregular surface on valve base are grinded off
 6. When valve base was grinded, coat valve surface with abrasive, then slightly grind the valve.

Caution:

- Powerfully grind may lead to valve base distort or damage.
- Frequently change angle of grinding tools can prevent uneven grinding.
- Don't let the abrasive get to place between valve rod and guiding tube

When grinded, please wash up the residual abrasive on cylinder head and valve, then check once again the contact surface of valve base.

Re-assemble cylinder head.

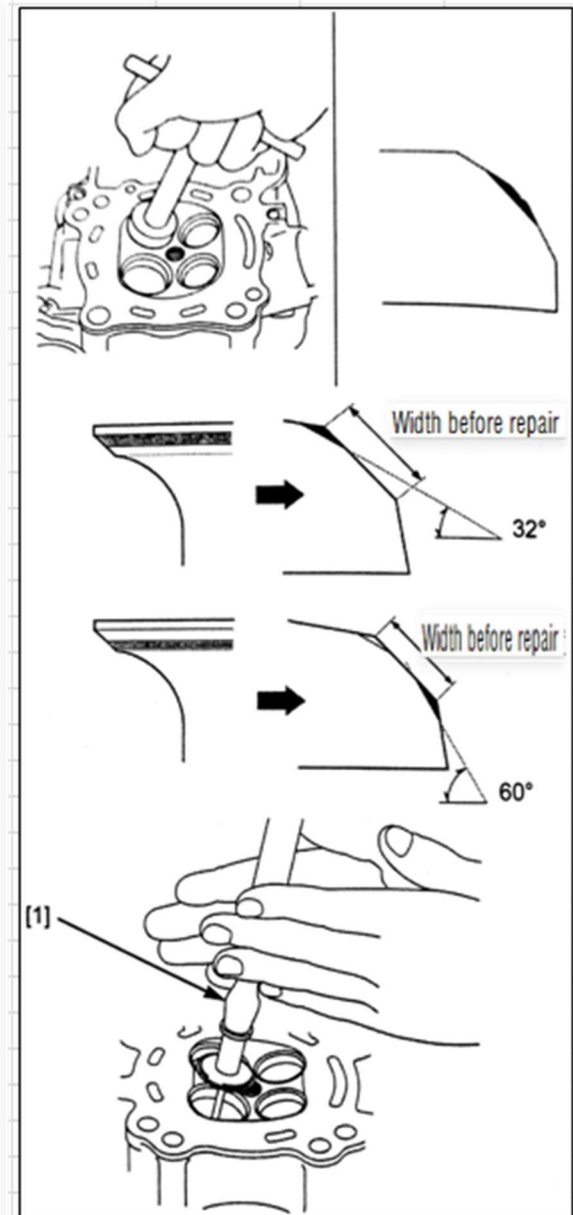

Assembly

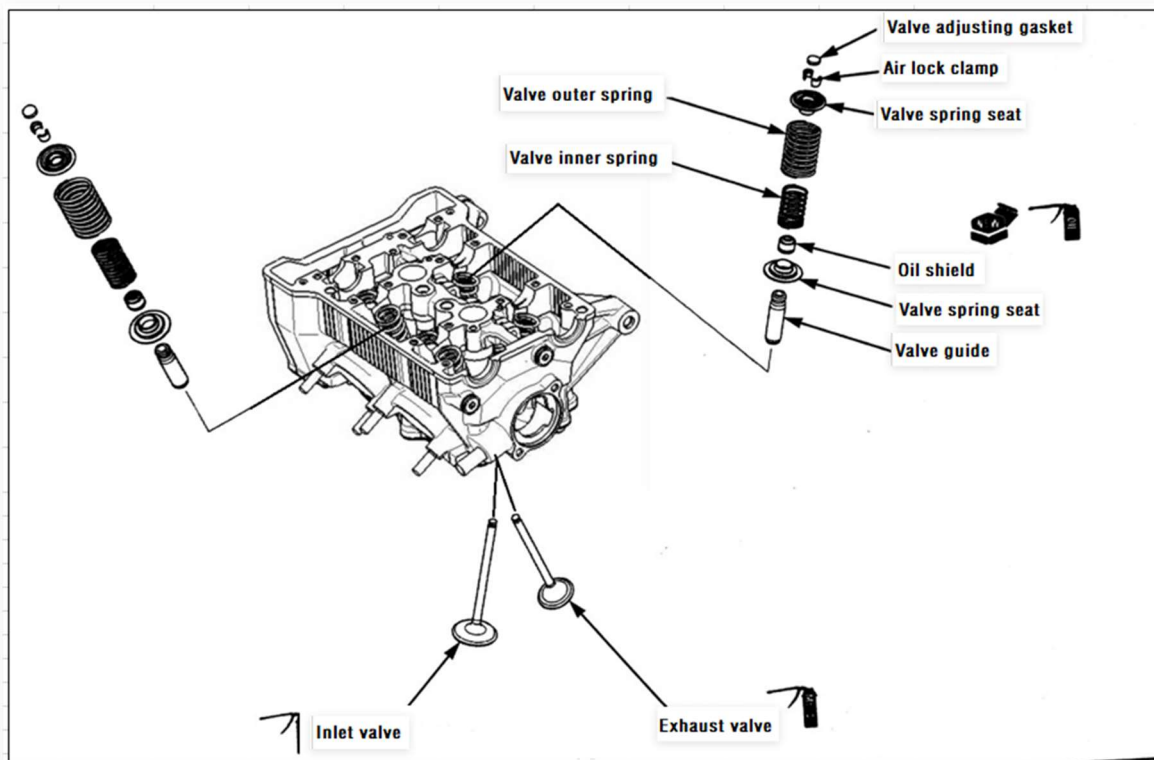

Wash cylinder head kit by cleanser, then blow all the oil passages by compressed air.

Lubricate new oil shield cover [1] by oil. Re-assemble lower valve spring base [2] and oil shield cover.

Lubricate sliding area of valve rod and rod end by solution of molybdenum disulfide.

Insert valve [3] into guiding tube, meanwhile slowly turning valve to avoid damage on oil shield cover.

Re-assemble spring base ring [6] for upper valve.

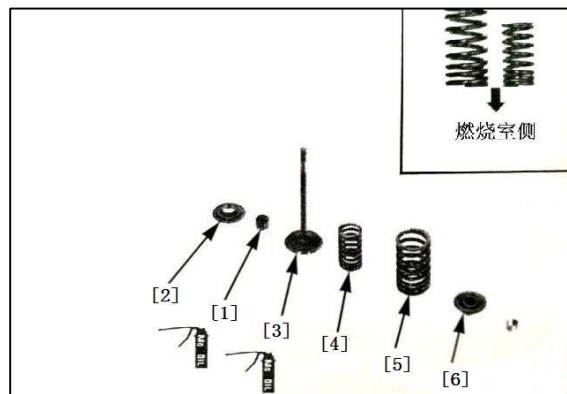

Re-assemble valve clip [1] by tools for it only.

Re-assemble inner valve spring [4] and outer valve spring [5], get thicker side of oil face to combustion chamber.

Lubricate split pin to reduce assembling resistance, please don't heavily press spring to keep its working performance.

Tool:

[2] Compression tool for valve spring

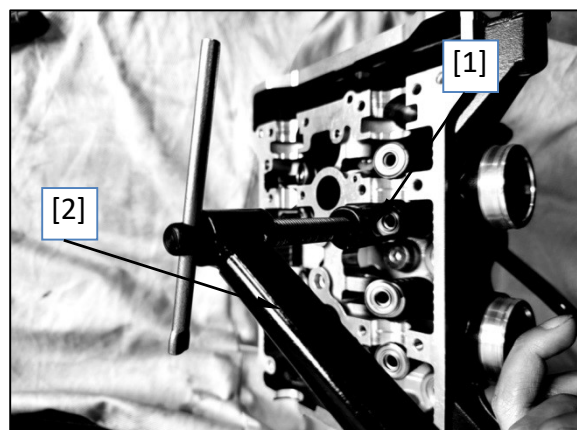

Hold cylinder head on working bench to avoid damage on valves.

Put suitable tool [1] into guiding tube [2].

Slightly knock to stably re-assemble lock clip.

Re-assemble parts below:

- Water temperature sensor
- Spark plug

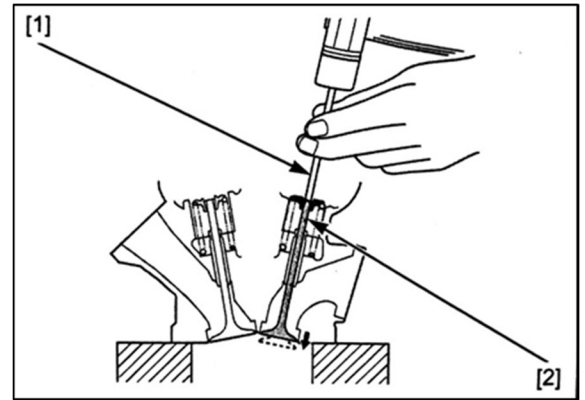

Re-assembly

Erase dirt on contact surface of cylinder.

Caution: Please prevent dust or dirt dropping into cylinder.

Insert water-proof bar [1] into air intake side on the right of cylinder head, whose taper surface faces downwards and gets its protrusion edge align to water sleeve of cylinder.

Caution:

The protrusion edge could be on left or right side.

Re-assemble guiding plate [1] for chain, then get its protrusion aligned to groove on cylinder, whose bottom is in groove of crankcase.

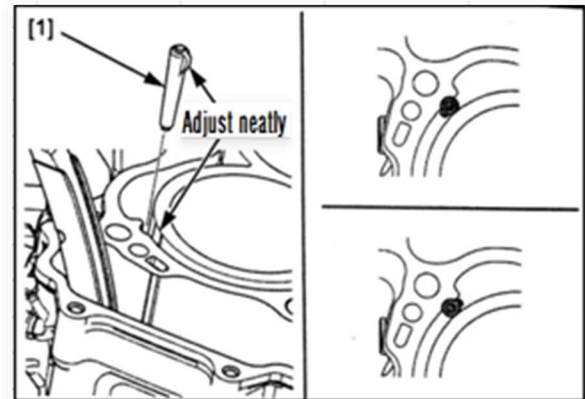

Re-assemble positioning pin [1] and new gasket [2].

Get timing chain through cylinder head, then re-assemble cylinder head to crankcase body.

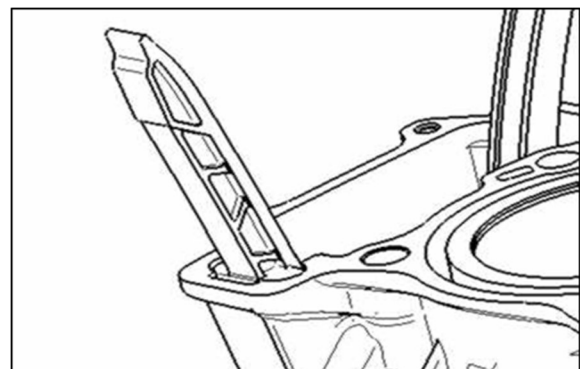

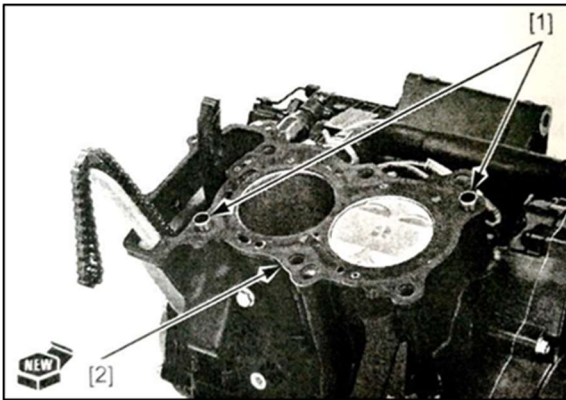

Totally clean up sealing bolt (9mm) for cylinder head, includes its thread and base surface, then wipe them up.

Coat thread and base surface of sealing bolt (9mm) for cylinder head with engine oil.

Re-assemble sealing bolt (9mm) [1] for cylinder head in alternative sequence by 2-3 times, then fasten to given torque.

Torque: 5N.m+15N.m+48N.m

Re-assemble and fasten bolt (M6) [2] of

cylinder head.

Re-assemble parts below:

- Thermostat
- Swinging arm

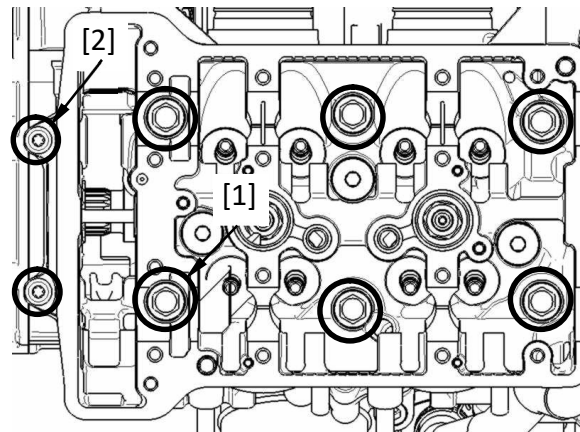

Adjustive stud of tensioner

Disassembly/Re-assembly

Caution:

Maintenance for adjustive stud of tensioner needn't remove engine from frame.

Remove sealing bolt [1] and seal ring [2].

Turn adjustive stud clockwise by too for it only and ensure its full tension.

Tool:

[3] Tensioner fixture

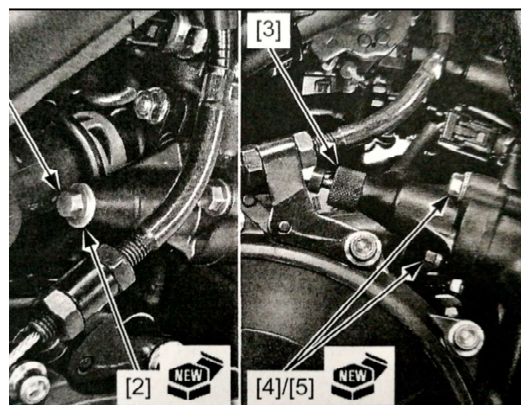

Remove installation bolt [4] and seal ring [5].

Remove adjustive stud [1] of tensioner and gasket [2].

The re-assembly is precisely opposite to disassembly.

Caution:

Replace seal ring and gasket a new one.

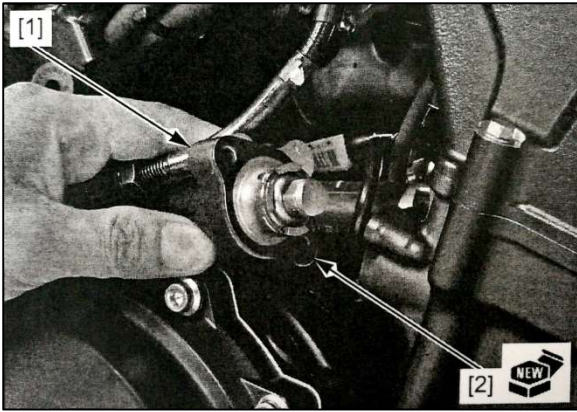

Inspection

Check operational performance for adjustable stud [1].

- When pressing adjustable stud, the stud could not be pressed into adjuster.
- When turning adjustable stud by cross sheet or screwdriver [2], the stud shall be able to press into adjuster, when removed tool, the adjustable stud shall bounce out of adjuster immediately.

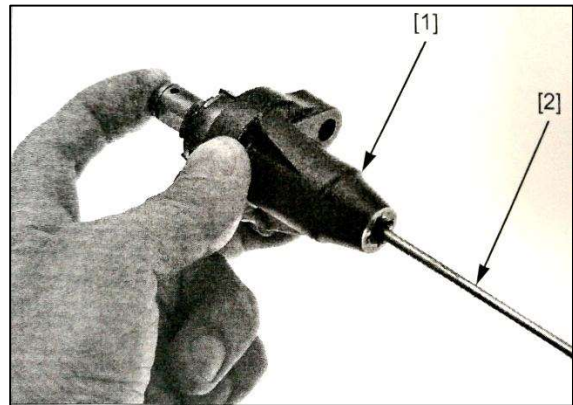

Timing chain/Sprocket wheel

Removal

Remove the parts below:

- Cylinder head
- Primary driving gear kit
- Outer case of clutch

Remove bolt [1], flat washer [2], tensioning plate [3] for chain and collar [4].

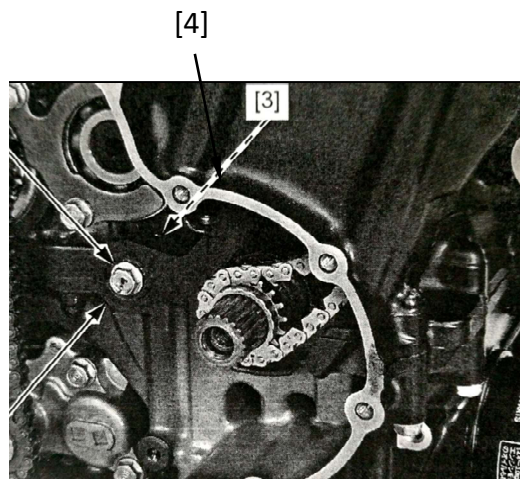

Remove timing chain [1] and timing sprocket wheel [2] from crankshaft.

Inspection

Check scratch, damage, wear-out or distortion on parts below, please replace if it is necessary.

- Timing chain
- Tensioning plate of chain

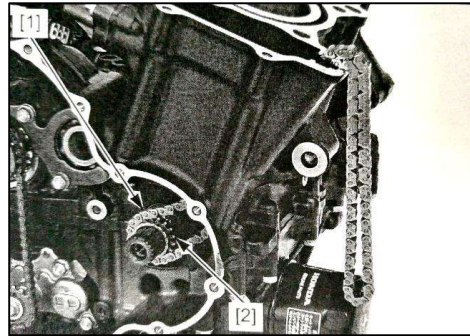

- Timing sprocket

Re-assembly

Re-assemble timing sprocket wheel [1], align wider tooth of socket spline of sprocket wheel to wider key groove on crankshaft.

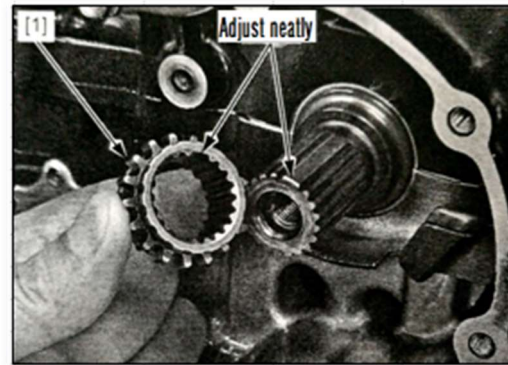

Coat overall surface of timing chain [1] with oil, then match to timing sprocket wheel and assemble.

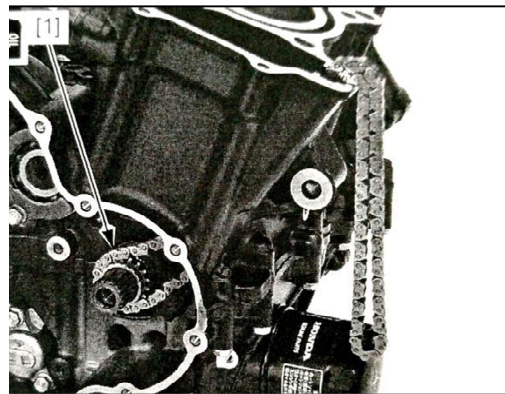

Coat thread of installation bolt for tensioning plate with Loctite.

Assemble collar [1], tensioning plate [2] of chain, bolt [3] and flat washer [4]. The assembling direction of collar is shown as picture.

Fasten installation bolt for tensioning plate of chain to given torque.

Torque: 11N • m

Assemble parts below:

- Outer case of clutch
- Primary driving gear

- Cylinder head

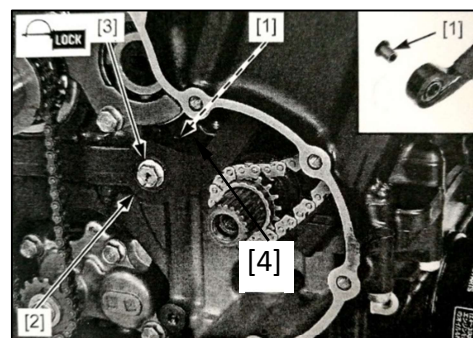

6 Clutch and gearshift

Maintenance

Summary

- The maintenance for clutch and gearshift device in this chapter needn' t remove the engine from frame.
- The oil level and viscosity has influence on separation of clutch. When the clutch failed to separate or the motorcycle is still in low speed when clutch separated, please check the oil level before clutch maintenance.

Tool

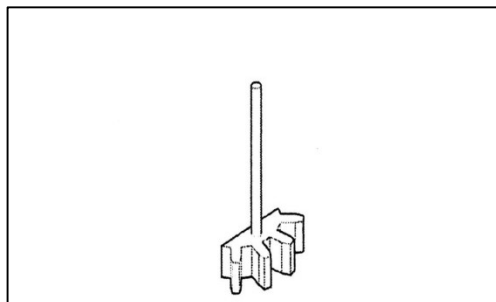
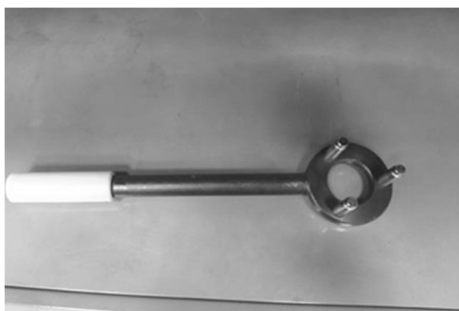

Specification for clutch and gearshift device

Unit: mm

Items		Standard	Maintenance limit
Free play for clutch lever		10-20	—
Clutch	Spring free length	45	43.8
	Friction plate thickness	2.92-3.08	2.82
	Driven plate flatness	—	0.05
Clutch collar	Internal diameter	21.992-22.007	22.017
	External diameter	27.995-28.008	27.985
External diameter at place of clutch collar		21.967-21.980	21.957

Troubleshooting

Difficult to hold clutch lever tightly

- The clutch cable damaged, twisted or too dirty
- Wrong wiring for clutch cable
- The thrust mechanism of clutch got damaged
- Malfunction in bearing of clutch' s pushing rod

- Incorrect installation for operational rod of clutch

Clutch skidding in acceleration

- Jamming on clutch' s pushing rod
- Driving friction plate worn out
- Poor performance for clutch spring
- Not any free travel on clutch lever
- Molybdenum disulfide or graphite additive gets into oil

When clutch separated or failed to separate, the motorcycle is still under low speed

- Too wide the free travel of clutch lever
- The friction plate of clutch gets warped
- Too high the oil level, wrong viscosity or incorrect additive
- The locking nut on clutch center case gets loosened
- Thrust mechanism of clutch gets damaged
- Incorrect installation for clutch' s operational rod
- The inserting groove on clutch outer case and clutch gear worn out
- Wrong operation for clutch

Difficult gearshift

- Incorrect adjustment for clutch cable
- Wrong operation on clutch
- Wrong viscosity of oil
- The gearshift fork gets damaged or bent
- The shaft of gearshift fork gets bent
- The claw of gearshift fork gets bent
- The bolt on five-star shaped plate gets loosened
- The five-star shaped turning plate gets damaged
- The guiding groove on gearshift drum gets damaged
- Five-star shaped turning plate gets worn out or damaged

Gear jump in transmission system

- Check plate gets worn out
- Poor performance even damage on returning spring of check plate
- The bolt on five-star shaped turning plate gets loosened
- Five-star shaped turning plate gets damaged
- Shaft of gearshift fork gets bent
- Gearshift fork gets bent or damaged
- The meshing surface or teeth groove gets damaged

Gearshift plate fails to return

- The poor elasticity of returning spring of gearshift spindle or gets cracked
- Gearshift spindle gets bent or damaged

Components layout

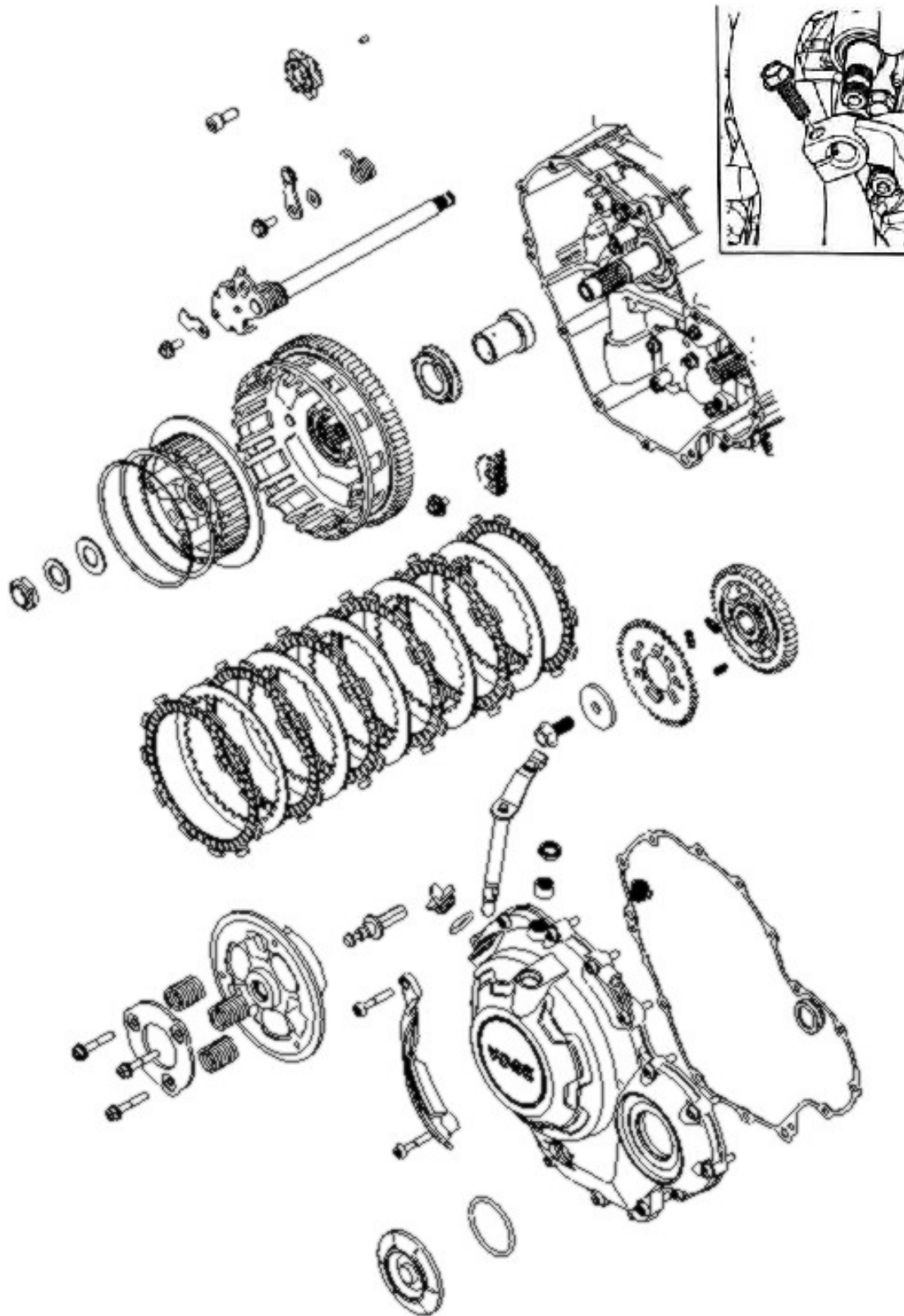

Right crankcase

Disassembly/Re-assembly

Remove fairing cover at lower side of motorcycle.

Drain off oil.

Remove bolt [1] and locating plate [2] for clutch, then remove clutch cable [4] from operational arm [3] of clutch.

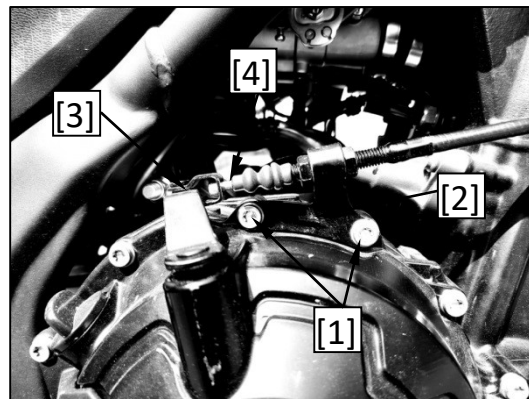

Remove wire clip [2] from supporting plate [1] of wind shield cover at lower side of motorcycle.

Remove bolt [3] and supporting plate [4].

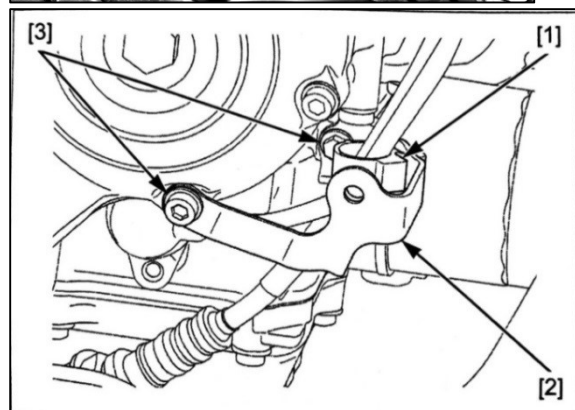

Loosen bolt [1] on right crankcase cover by 2-3 steps.

Remove parts below:

- Bolt [1].
- Right crankcase cover [2].
- Right decorative cover [3]

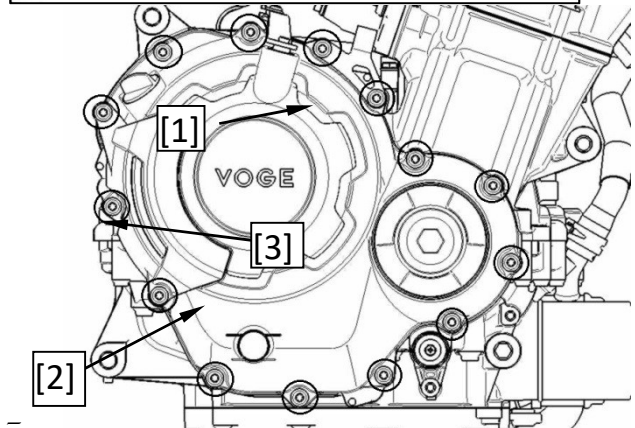

Remove positioning pin [1] and gasket [2].

Clean up residual gasket on contact surface between crankcase and cover, please don't damage the contact surface.

The re-assembly is opposite to disassembly.

Torque:

Bolt of right crankcase cover: 11N.m

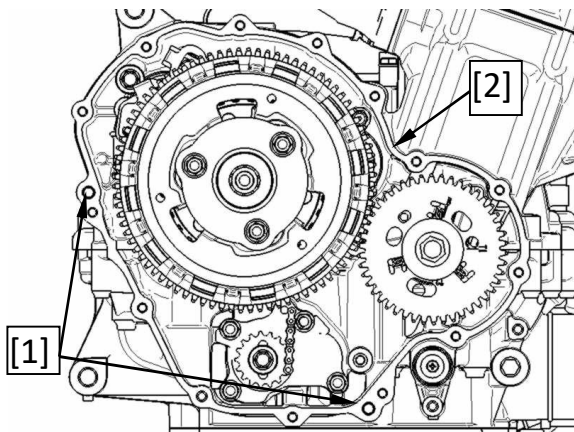

Caution:

- Coat contact surface of crankcase with sealant for end surface as picture shows.
- Replace gasket for right crankcase cover for a new one.
- Align groove on locating plate for clutch cable to protrusion on right crankcase cover.

Adjust free play for clutch lever.
Fill up crankcase with suggested oil

Disassembly/Re-assembly

Remove operational arm [1] of clutch and returning spring [2] from right crankcase.

Caution:

Remove oil seal [1] from right crankcase cover. The re-assembly is opposite to disassembly.

- Coat new oil seal with grease.
- Assemble oil seal to given depth as picture shows.
- Align hook on returning spring to gap on right crankcase.
- Align returning spring to groove on operational arm of clutch.
- Coat sliding surface of operational arm and pushing rod with oil.

Inspection

Check if there is scratch, damage, wear-out and distortion on parts below.

- Shaft sleeve for operational arm of

and check if there is oil leaks.

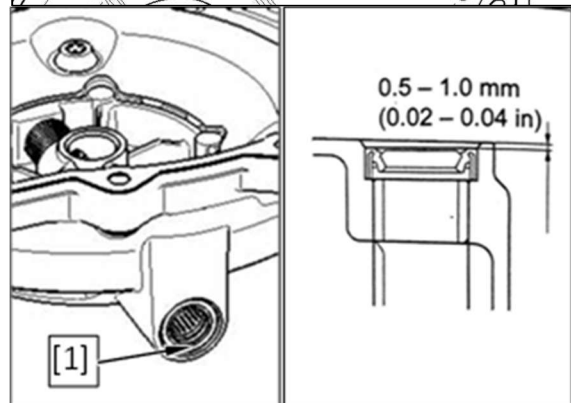
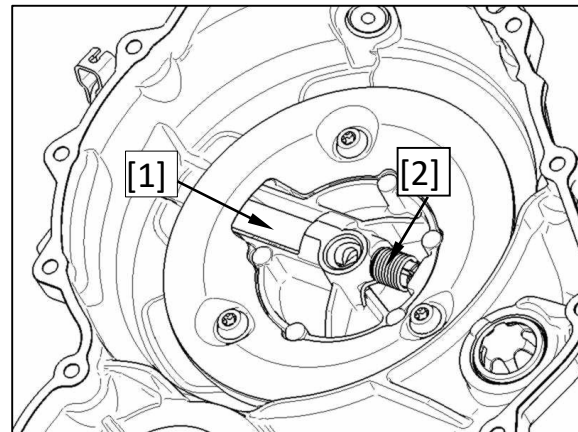
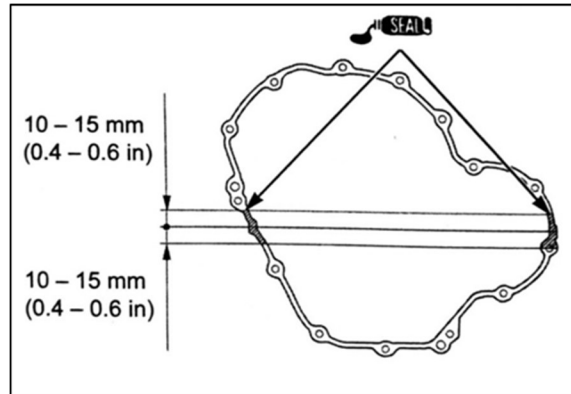

clutch

- Operational arm of clutch
- Returning spring
- Smaller pushing rod

Clutch

Disassembly

Remove right crankcase cover.

In case clutch collar needs be removed, remove bolt [1] of driven gear of oil pump when clutch is under re-assembling condition.

Loosen bolt [1] of lift plate of clutch by 2-3 steps, remove lift plate [2], pulling rod [3], pressing plate [4] and clutch spring [5].

Remove locking flange for central locking nut of clutch.

Caution:

Please don't damage threaded part of main shaft.

Fix pressing plate of clutch by tool, then loosen locking nut [1].

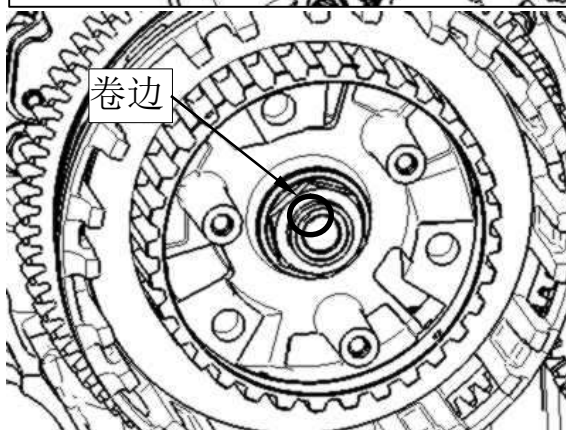
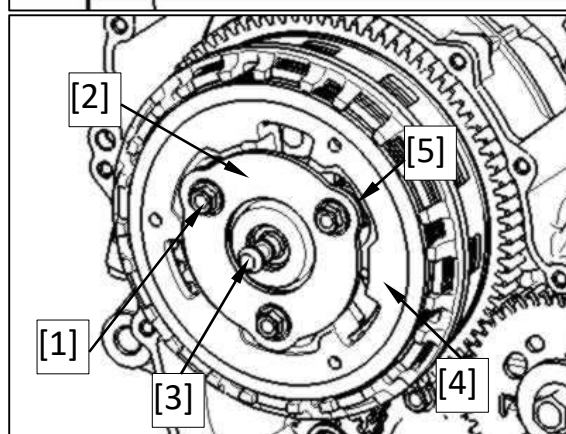
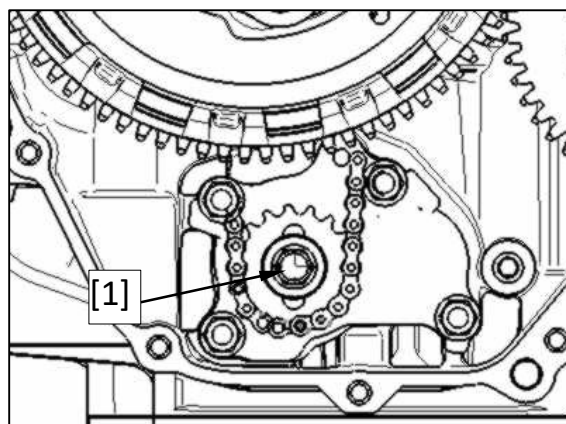

Remove locking washer and shim.



Remove central case kit [1] of clutch.



Remove parts below:

- Central case
- Driving friction plate
- Driven friction plate
- Pressing plate

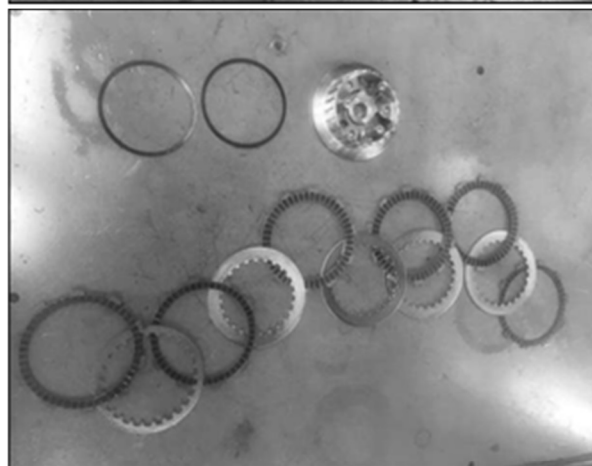

Remove thrust washer.

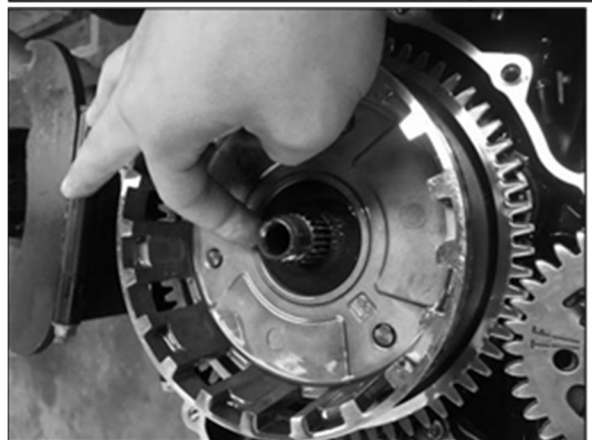

Insert screwdriver into groove [1] on primary driving gear and move gear, get the tooth of gear to primary driven gear, then install a bolt [2] of 6×14mm at locating hole of locating hole on primary driving gear.

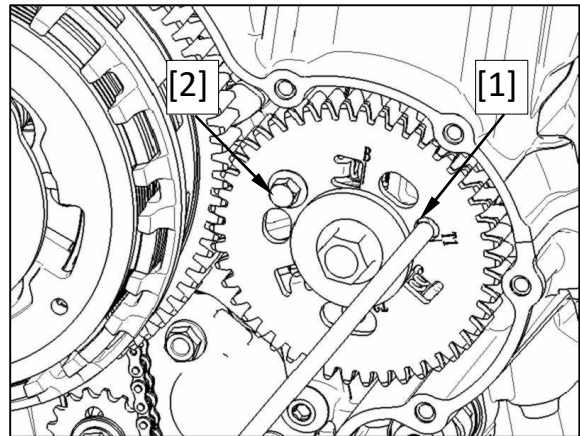

Remove outer case [1] of clutch.

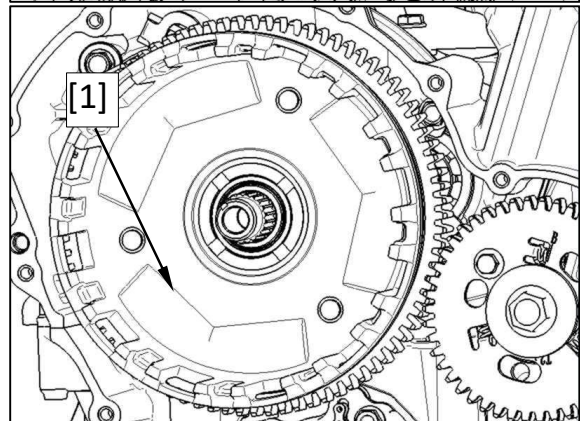

Remove parts below:

- Fastening bolt [1] for driven sprocket
- Driven sprocket wheel [2] of oil pump
- Chain [3] of oil pump
- Driving sprocket wheel [4] of oil pump

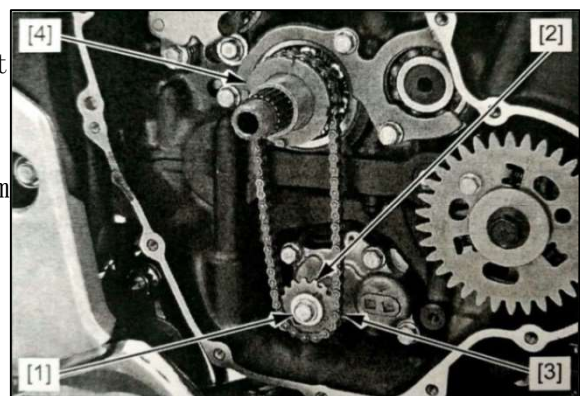

Remove collar [1] of clutch.

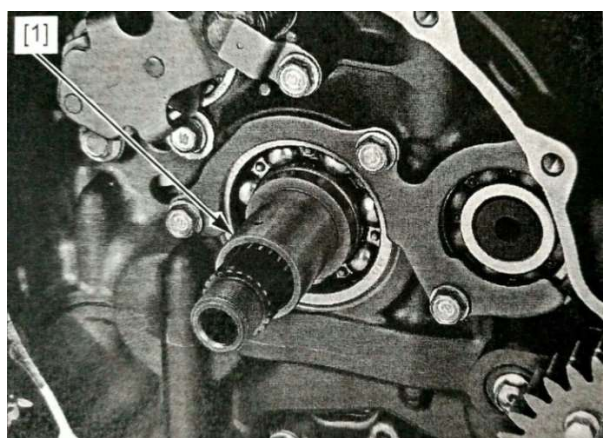

Inspection

Check and confirm if there is scratch, damage, wear-out or distortion on parts below, in case it is, please replace.

- Pushing rod of clutch
- Operation arm for clutch
- Lift plate for clutch
- Spring
- Central case of clutch
- Washer
- Disc spring
- Driving and driven friction plate
- Outer case of clutch/Primary driven gear
- Needle bearing/Collar
- Collar for clutch
- Main shaft

Caution:

- Replace clutch spring as a kit.
- Replace driving and driven friction plate as a kit.

Re-assembly

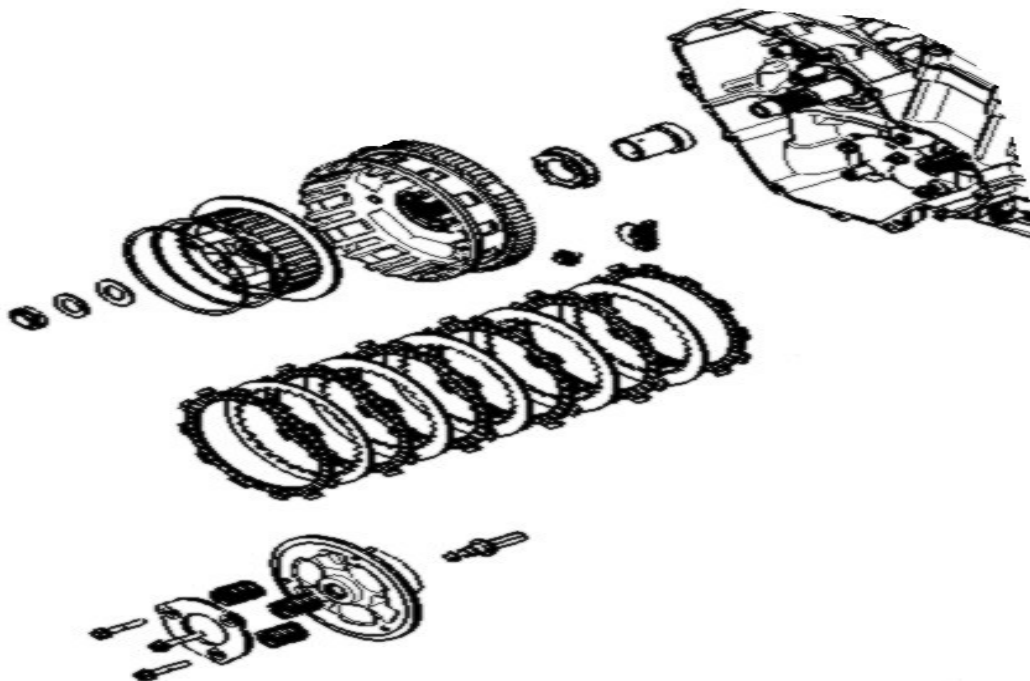

Coat external surface [1] of clutch collar with solution of molybdenum, then assemble it to main shaft.

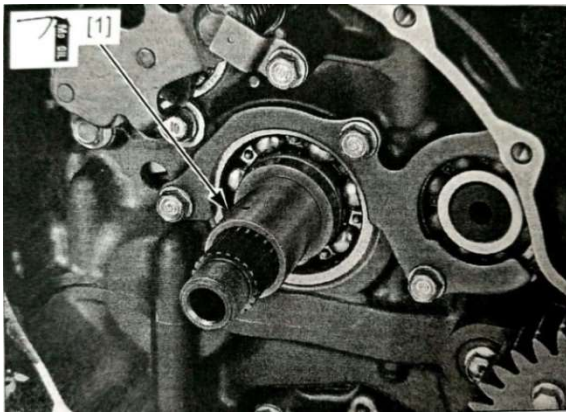

Coat driving and driven gear of oil pump and driving chain with clean engine oil.

Assemble driving gear [1] and driving chain [2], please get protrusion on driving gear face outwards [3].

Assemble driving gear [4] of oil pump.

Coat thread of driving bolt for driven gear of oil pump with Loctite.

Assemble seal bolt [5] for driven gear of oil pump, Fastening torque: 11N.m.

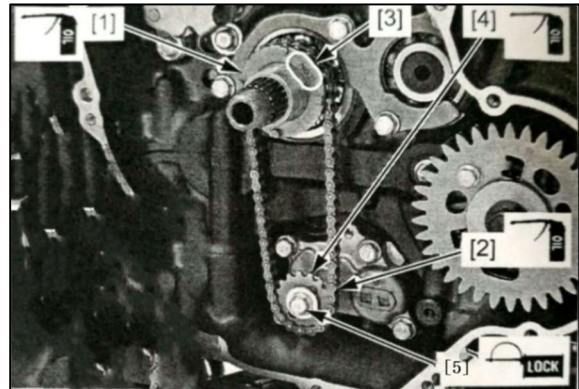

Coat internal and external hole of needle bearing of outer case of clutch with clean engine oil, also coat surface of primary driving and driven gear with it.

Re-assemble outer case [1] of clutch, then align the hole on case to protrusion on driving gear of oil pump. .

When assembling outer case, please turn driven gear of oil pump.

Caution:

- Please ensure correct meshing [2] between driving and driven gear.
- Remove bolt [3] of 6×14mm from primary driving gear.
- **When outer case of clutch assembled, please don't forget to remove bolt of 6×14mm.**

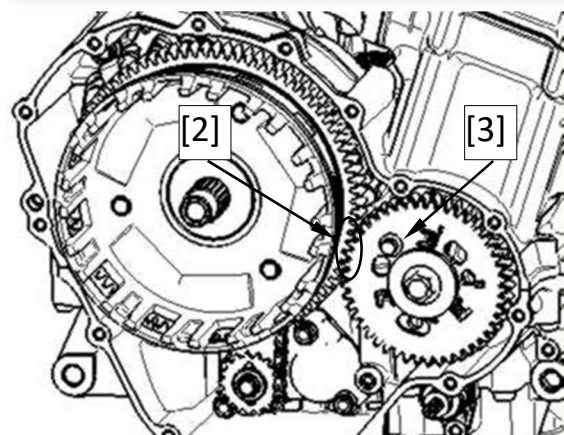

Assemble thrust washer [1].

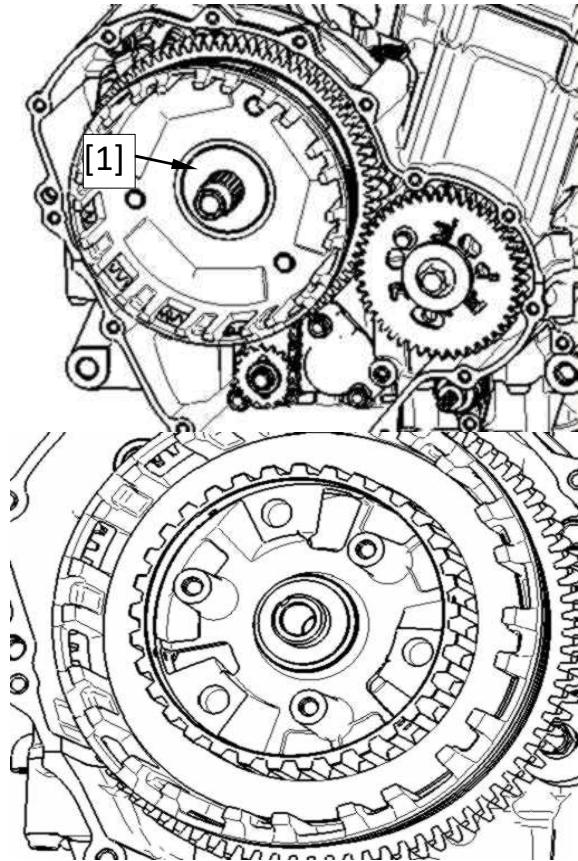

Assemble central case body

Assemble flat washer

Assemble butterfly shaped washer

Caution:

*Get bigger end of washer face upwards
(Mark "OUTSIDE" face outwards) .*

Coat locking nut of clutch, thread and base surface with clean engine oil, then assemble locking nut to main shaft.

Fix pressing plate by tool, then fasten locking nut.

Torque: 130N.m



The assemble protrusion on locking nut into groove on main shaft.

Caution:

Please don't damage threaded part of main shaft.

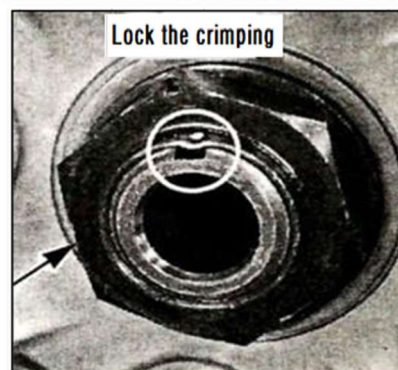

Coat friction plate of clutch with clean oil.

Assemble central case body [1] onto main shaft.

Assemble flat washer [2] and butterfly shaped washer [3] into central case body.

Caution:

Get bigger end of butterfly-shaped washer [3] facing outside.

Assemble driving friction plate (Inner diameter 120) [4], driving friction plate (Inner friction plate 116) [5] and driven friction plate (Inner diameter 104) [6]

Assemble pushing rod [1] onto main shaft.

and driven friction plate (Inner diameter 112) [7] as picture on right shows.

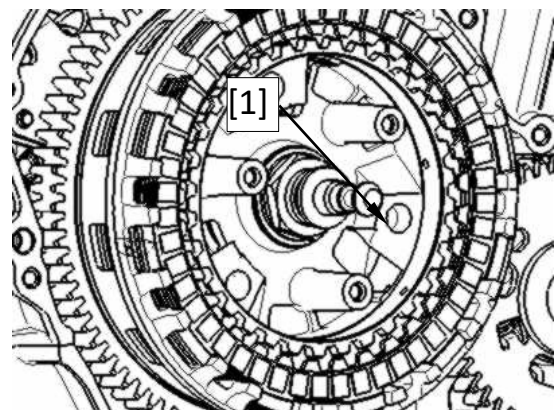
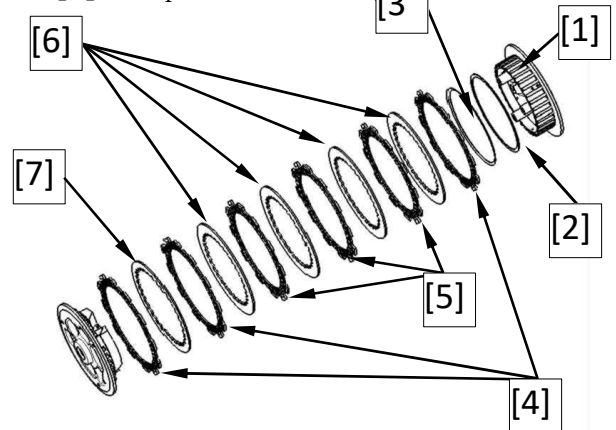

Assemble pressing plate onto central case, then get pressing plate and tooth of driving friction plate aligned.

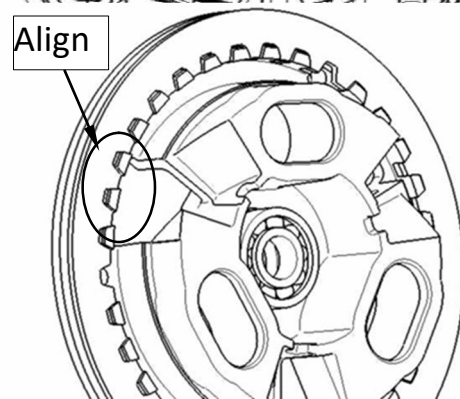

Caution:

Please confirm if the pressing plate was assembled in place, the picture shows the plate surface [1] get basic flat to end surface [2] of outer case, whose height difference shall be lower than 2mm.

In case height difference fails to meet demands, it mainly due to driven plate failed to drop into its groove, whose forced press-fitting is not allowed, which needs be assembled once again.

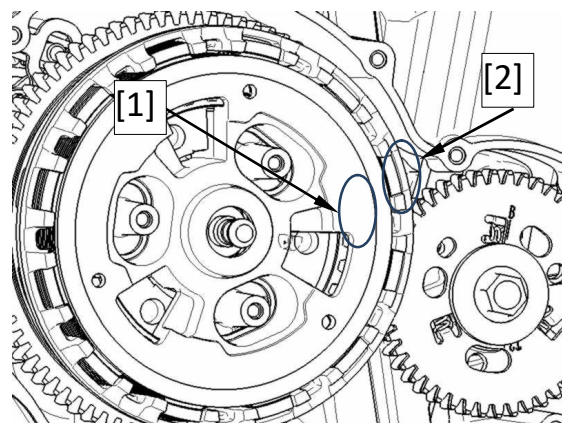

Assemble main spring [1], lift plate [2] and its bolt [3] of clutch.

Alternatively fasten bolts of lift plate by 2-3 times and fasten to given torque.

Torque: 12N.m

Caution:

Pushing rod needs be freely turned, in case there is jamming, please assemble pushing rod once again or replace it for a new one.

Fasten locking bolt [1] of driven sprocket wheel to given torque.

Torque: 11N.m

Assemble right crankcase cover.

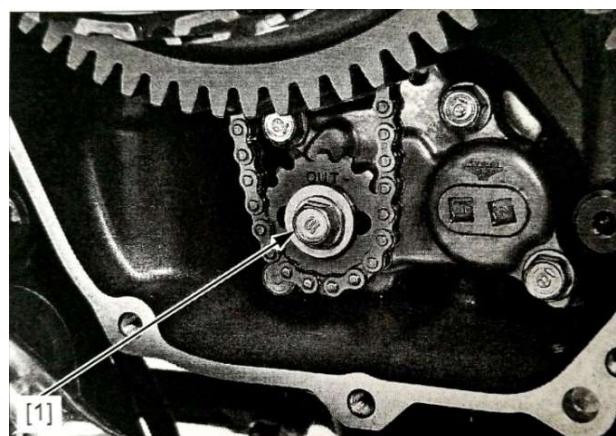
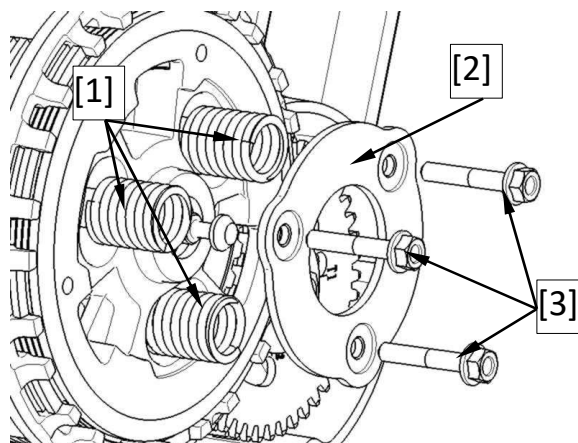

Primary driving gear

Removal

Remove right crankcase cover.

Assemble a bolt [1] of 6×14mm at locating hole on primary driving gear.

Fix primary driving gear [2] by tool, then remove its bolt [3] and washer [4].

Tool:

[5] gear stopper, 2.5

Remove gear stopper and primary driving gear.

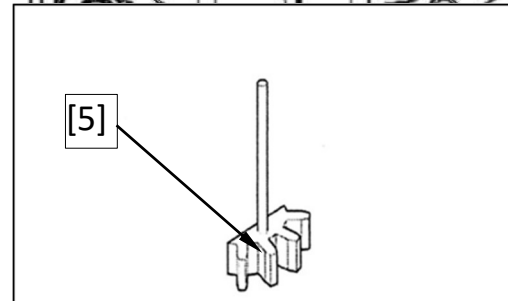
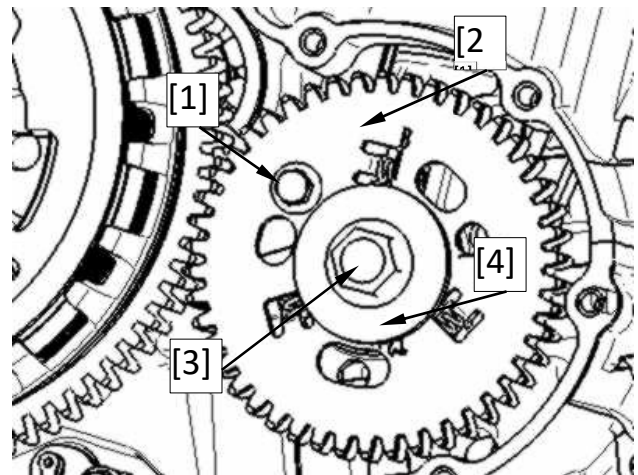

Remove bolt [1] of 6×14mm and auxiliary gear [2] of primary gear.

Remove spring [3] from groove of auxiliary gear.

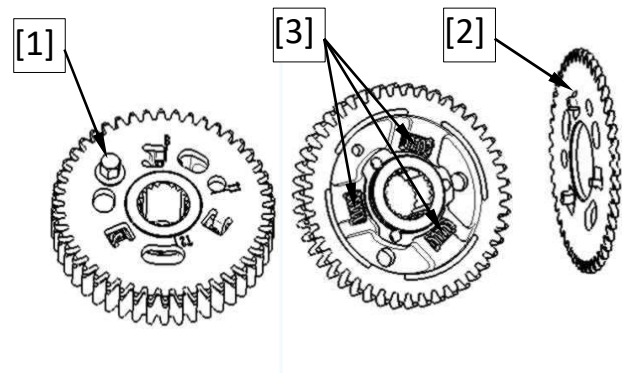

Inspection

Please check if there is scratch, damage, wear-out or distortion on parts below, please replace if it is necessary.

- Remove main gear of primary driving gear
- Auxiliary gear
- Spring

Re-assembly

Coat sliding area of primary gear and its auxiliary gear with solution of molybdenum.

Assemble spring [1] to gear groove on primary driving gear [2].

Assemble auxiliary gear to primary driving gear, then get lable place at end position of spring, then get index line for mark “B” align to wide tooth as picture shows.

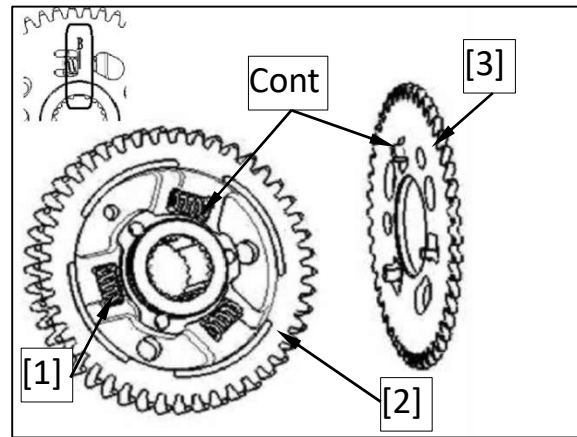

Loosely assemble a bolt of 6×14mm [1] to prevent dropping off.

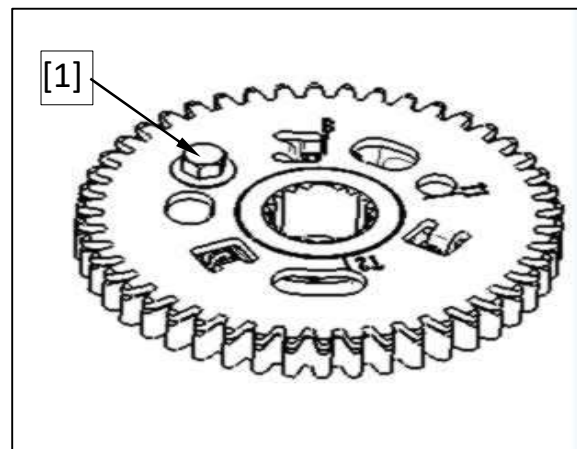

Assemble primary driving gear [1] to crankshaft.

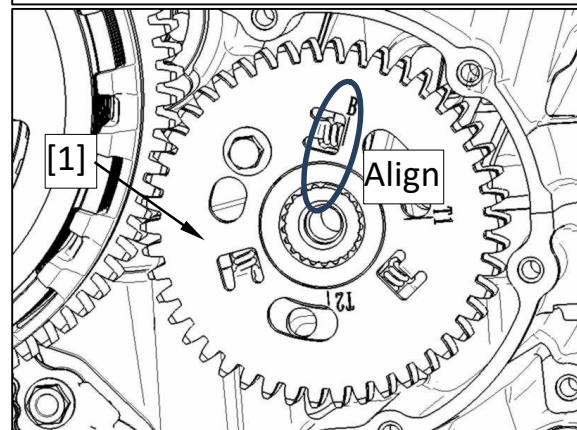

Insert screwdriver into groove [1] on primary driving gear, then get auxiliary gear and main gear overlapping.

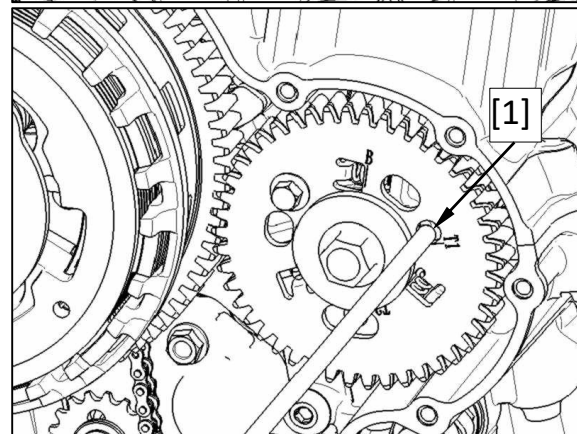

Coat thread of bolt for driving gear and contact place with clean engine oil.

Assemble washer [1] and bolt [2] of driving gear.

Fix driving gear by tool and fasten bolt to given torque.

Tool: Gear stopper, 2.5

Torque: 95Nm

Remove gear stopper [3].

Remove bolt [4] of 6×14mm.

Caution:

When primary driving gear was assembled, please don't forget to remove bolt 6×14mm.

Assemble right crankcase cover.

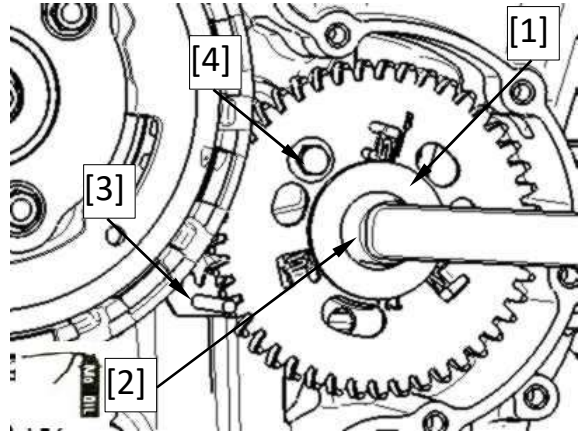

Gearshift system

Removal

Remove parts below:

- Clutch
- Gearshift arm

Clean up dirt on spline of gearshift spindle.

Remove bolt [1] and limit plate [2].

Pull off gearshift spindle kit [1] and thrust washer from crankcase.

Remove socket hex. bolt [1] of five-star shaped plate.

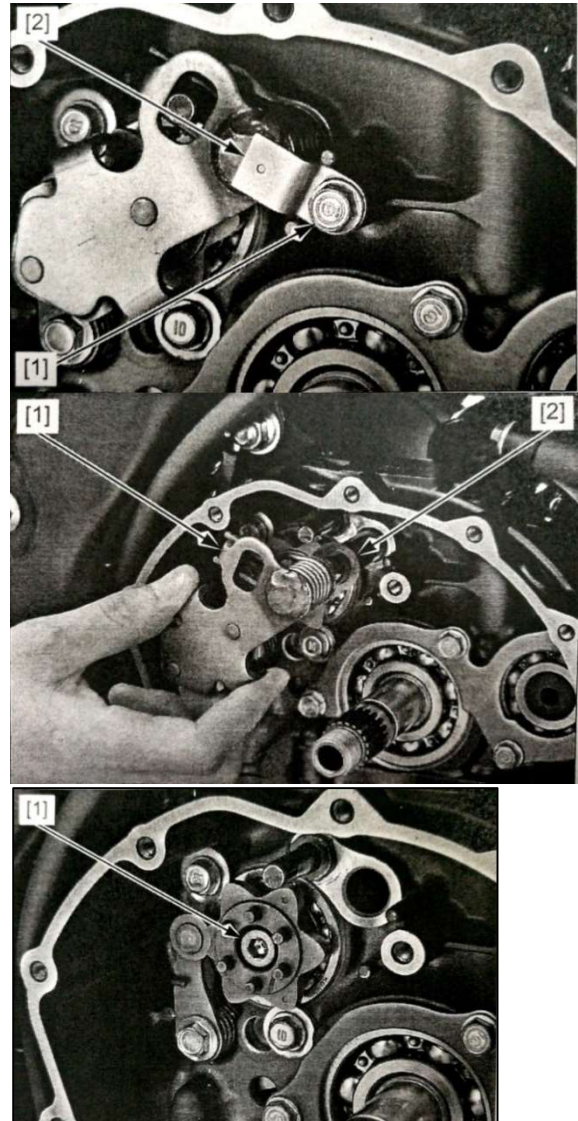

Fix check plate [2] by screwdriver and remove five-star shaped plate as picture shows.

Remove parts below:

- Positioning pin [3]
- Check plate and locating bolt [4]
- Check plate
- Washer [5]
- Return spring [6]

Remove bolt [1], pressing plate [2] for oil seal of gearshift spindle, oil seal [3] and needle bearing [4].

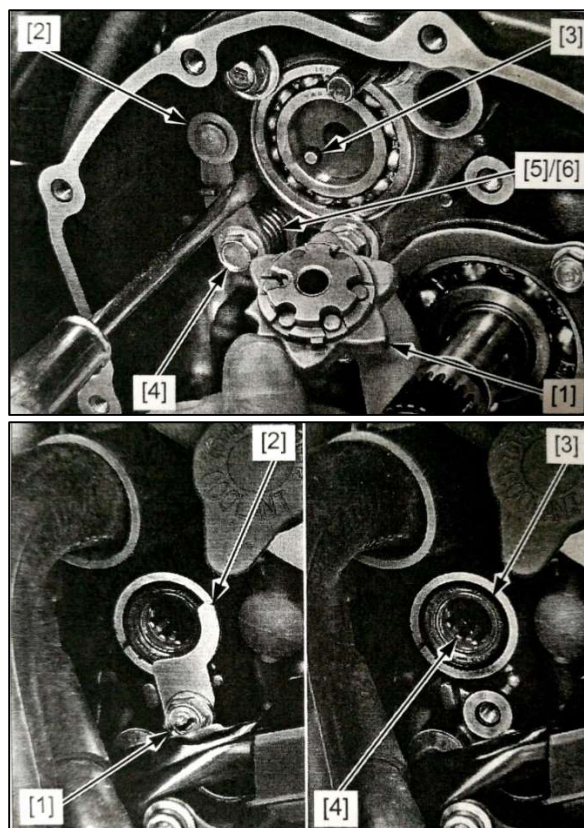

Inspection

Check if there is damage, wear-out or distortion on parts below. Please replace if it is necessary.

- Five star-shaped plate
- Check plate
- Return spring for check plate
- Needle bearing for gearshift arm

Gearshift arm

Check if there is wear-out or fatigue of twist spring [1] of gearshift arm and that [2] on gearshift plate, please replace if it is necessary.

Check if there is wear-out or distortion on gearshift spindle [3].

Check if there is damage, wear-out or distortion on checkplate [4] of gearshift.

In case replacement is necessary, please replace gearshift spindle kit as a complete set. .

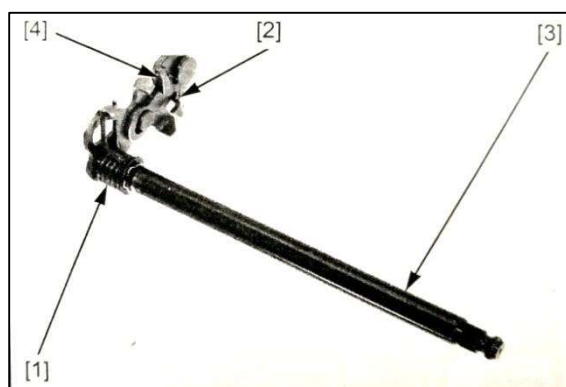

Re-assembly

Coat needle bearing [1] of gearshift arm with clean engine oil, then assemble it to crankcase.

Coat edge [2] of new oil seal with grease, then assemble it into crankcase, make sure its surface is aligned to root place of chamfer of crankcase.

Coat threaded part of bolt for pressing plate of oil seal for gearshift spindle with Loctite.

Assemble pressing plate [3] of oil seal for gearshift arm in direction as picture shows, fasten bolt [4] to given torque.

Coat threaded part of bolt for check plate with Loctite.

Assemble return spring [1], washer [2] and check plate [3], then assemble hook of return spring into goove on check plate.

Assemble bolt [4] of check plate to given torque.

Torque: 11N. m

Check normal operation for check plate.

Coat threaded of locating bolt for five-star shaped plate with Loctite.

Assemble positioning pin [1] into its pin of gearshift drum.

Fix check plate [2] by screwdriver as picture shows.

Assemble five-star plate [3] and align its narrow groove to positioning pin.

Assemble locating bolt [1] of five-star plate and fasten to given torque.

Torque: 23N. m

Torque: 11N. m

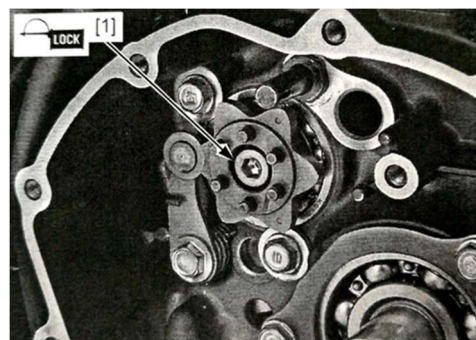
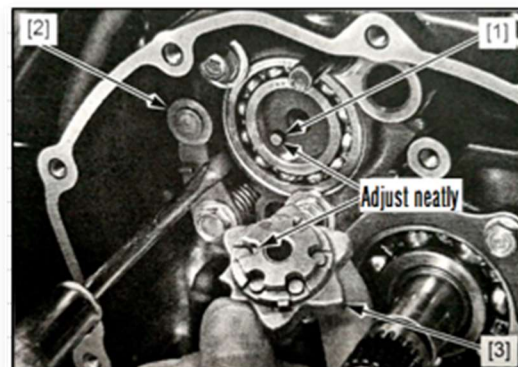
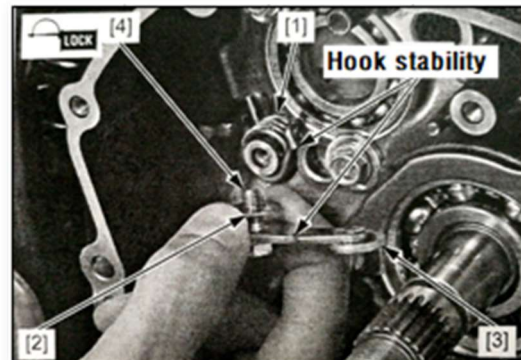
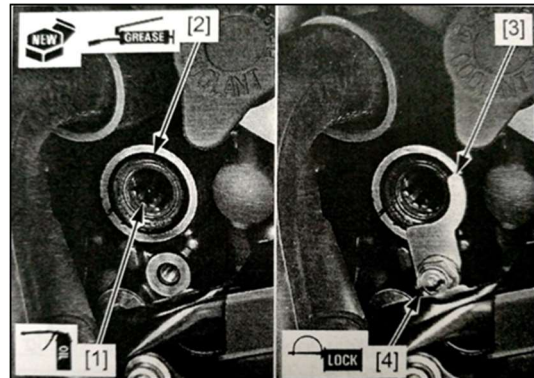

Coat external surface of gearshift spindle with clean engine oil.

Assemble thrust washer [1] and gearshift spindle kit [2] into crankcase, then align end part of return spring to its pin.

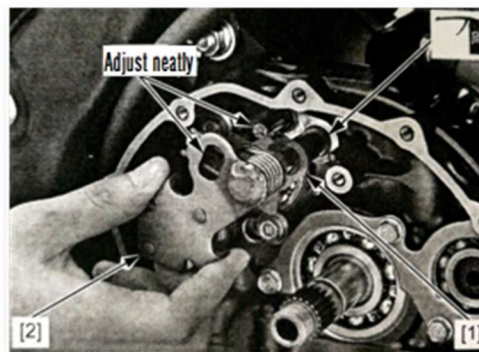

Coat threaded part of bolt for pressing plate with Loctite.

Assemble pressing plate [1] and Bolt [2], then fasten to given torque.

Torque: 11N.m

Assemble parts below:

- Gearshift rod
- Clutch

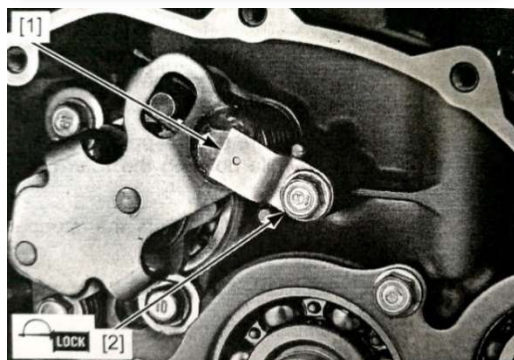

Disassembly/Re-assembly for

Remove locking bolt [1] and gearshiftrd [2] from gearshift spindle.

Remove locating bolt [3] and gearshift pedal [4].

Remove dust-proof ring [5].

Check if dust-proof ring or dust cover of ball joint of pulling rod got bad or worn out, please replace if it is necessary.

The re-assembly is opposite to disassembly.

扭矩:

Locating bolt for gearshift pedal:
27N.m

Caution:

- Coat edge of dust-proof ring with Loctite.
- When assembling dust ring, please let its edge side face outside.
- Coat sliding bolt for shaft place of sliding area for gearshift pedal with Loctite.
- Coat ball joint of pulling rod of gearshift pedal with Loctite.

When adjusting height of gearshift pedal, please do this work by loosening locking nut [1], while paying attention to points below:

Caution:

- Turn left the thread when locking up nut for gearshift arm end.
- Adjust distance between two ball joints of adjusting rod to standard one as picture shows.
- When it was adjusted, fasten locking nut of gearshift pedal.
- Fasten locking nut, get ball joint at parallel position between gearshift arm and pedal.
- Make sure length of thread of

gearshift pedal

- Align narrow seam on gearshift arm to matching hole on shaft.

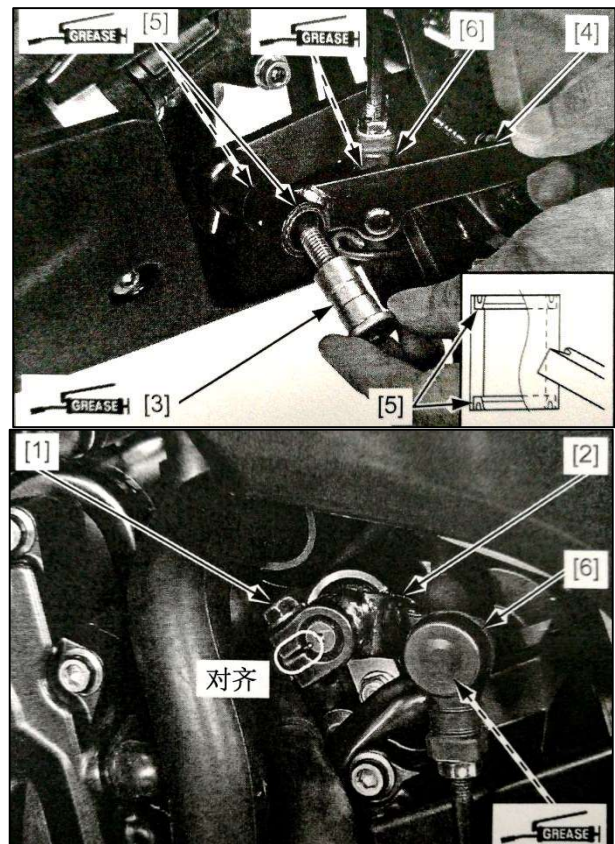

locking nut is less than given length.。

- End of gearshift arm: 8.5mm
- End of gearshift pedal: 8.0mm

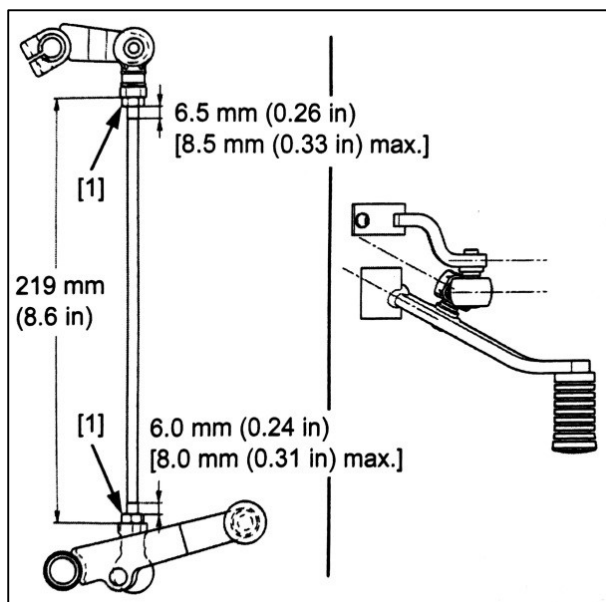

7 Magneto and starting clutch

Summary

- The maintenance for stator and rotor of magneto needn't remove the engine from frame.
- Check about the charging coil of alternative power generator.
- Check about the trigger.
- Maintenance about starting motor.

Specification for magneto and starting clutch

Unit:mm

Items	Standard	Limit
External diameter for shaft jacket of starting plate shaped gear	51.705-51.718	51.685
Internal diameter for outer case of starting clutch	68.362-68.392	68.402

Tool

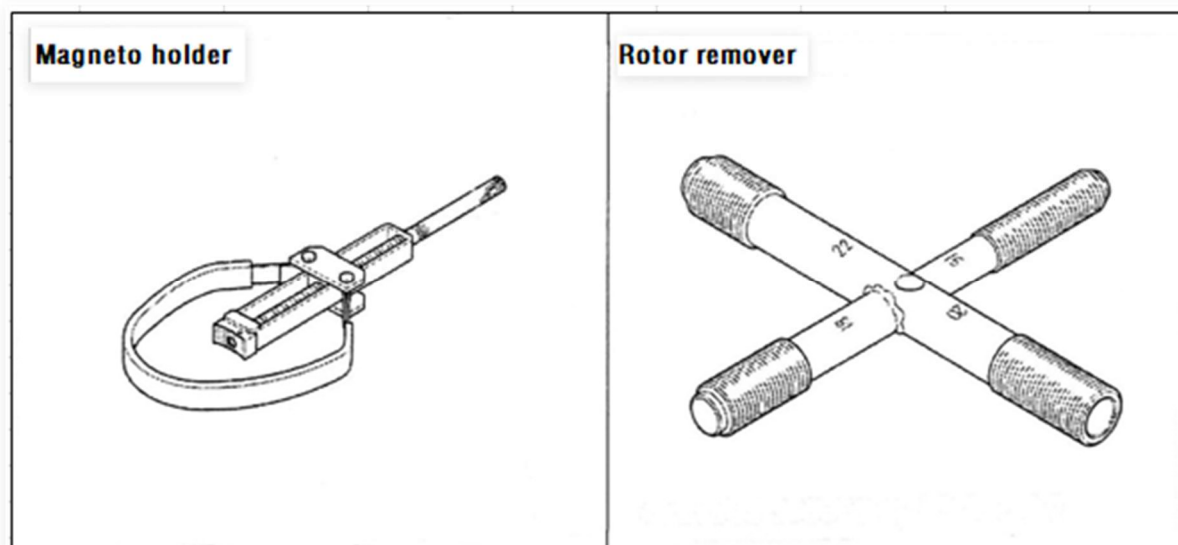

Troubleshooting

Starting motor is run, while engine failed starting

- Malfunction in starting clutch
- Malfunction in double gear or its shaft of starting motor
- Smaller gear of starting motor in malfunction or worn out

- Malfunction in driving gear of starter

Components layout

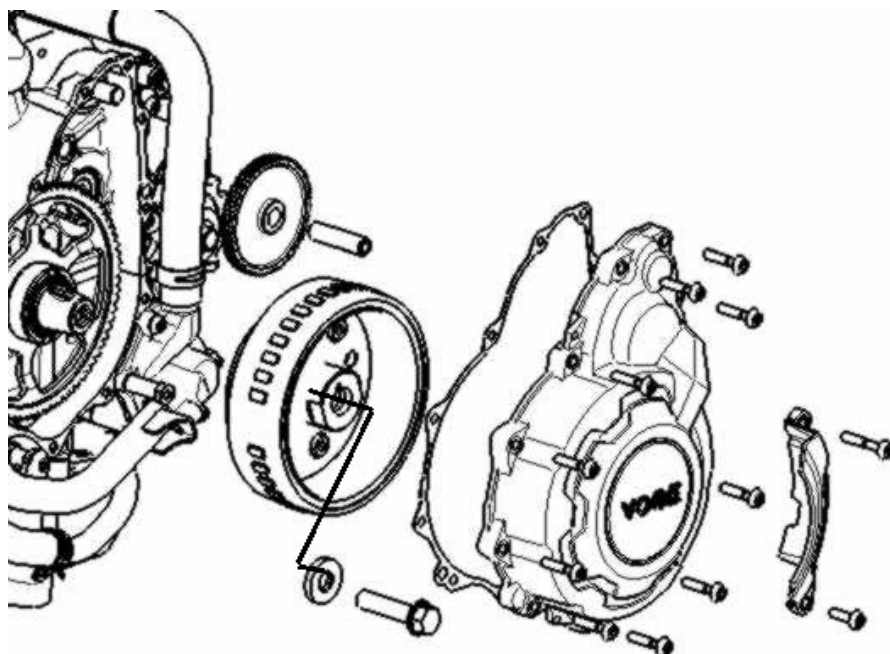

Left crankcase cover

Disassembly/Re-assembly

Caution:

- When removing left crankcase cover, lay a clean oil tray under engine to prevent oil flowing out. When re-assembled, fill up with appointed oil to given amount.

Keep motorcycle upright on horizontal ground.

Remove parts below:

- Shield cover for bottom of motorcycle

Remove trigger line [2] for wire clip [1].

Cut off red wire joint [3] for trigger.

- Cover for driving sprocket wheel

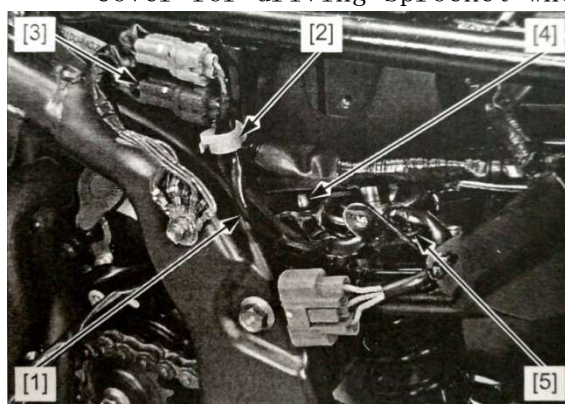

Remove stator of magneto from frame, then wire clamp of trigger (Brown [4] and black [5]).

Remove stator of magneto and wire [1] of trigger from frame.

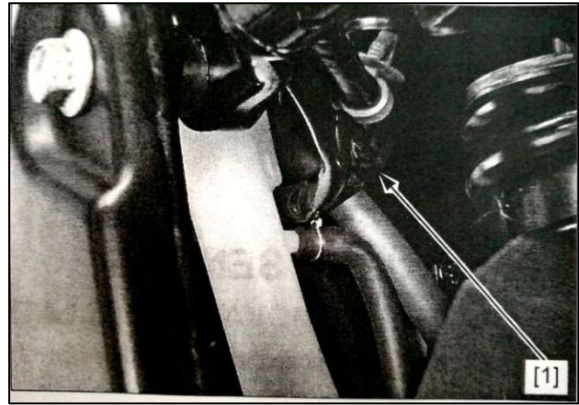

Remove fixing bolt [1] for left decorative cover and then cover [2], loosen bolts [3] on left crankcase by steps in diagonal sequence.

Remove parts below:

- Bolt
- Left crankcase cover [4]

Caution:

The left crankcase cover (Stator) is under magnetic stress of rotor, be careful when disassembling and re-assembling.

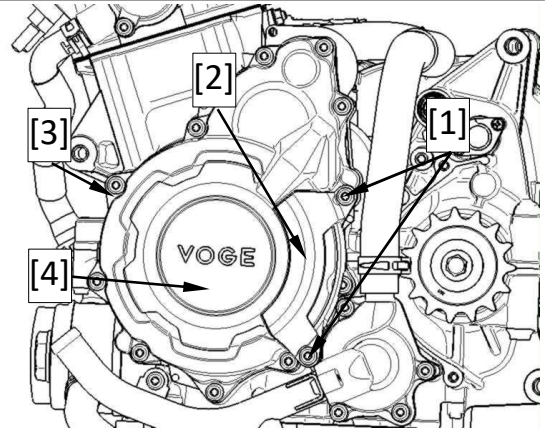

Remove positioning pin [1] and gasket [2].

Clean up residual gasket material on contact surface between left crankcase and its cover.

The re-assembly is opposite to disassembly.

Torque:

Bolt for left crankcase cover: 11N.m

Caution:

- Coat contact area of crankcase with sealant as picture shows.
- Replace gasket of left crankcase for a new one.

Check oil level.

Make sure there is not any oil leaks.

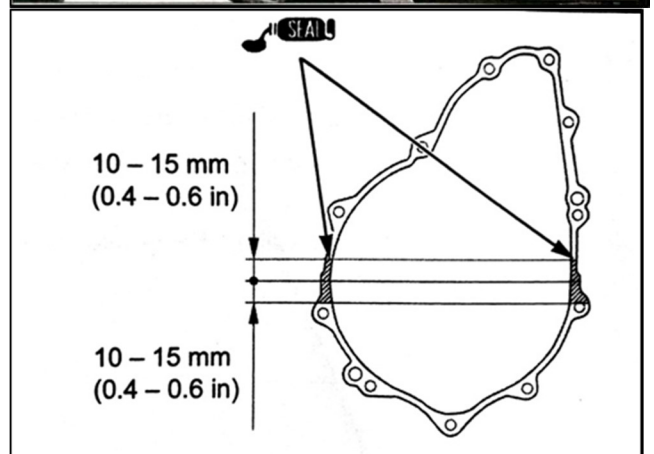
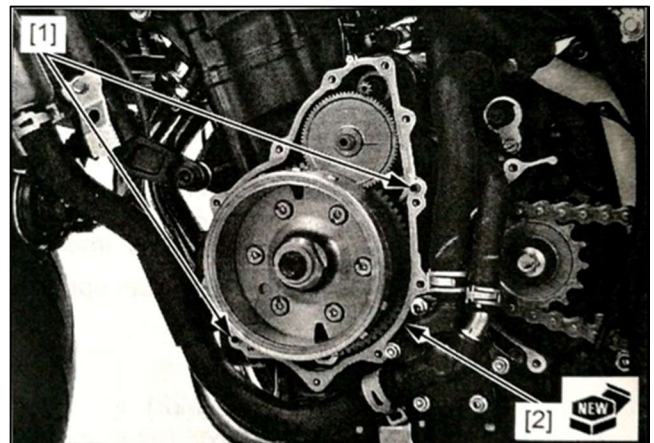

Stator of magneto and trigger

Disassembly/Re-assembly

Remove left crankcase cover.

Remove and assemble stator/trigger as picture below shows.

- Coat threaded part of stator and bolt for trigger with Loctite.
- Coat sealing surface of magneto/wire joining ring of trigger with sealant for end surface.

The re-assembly is opposite to disassembly.

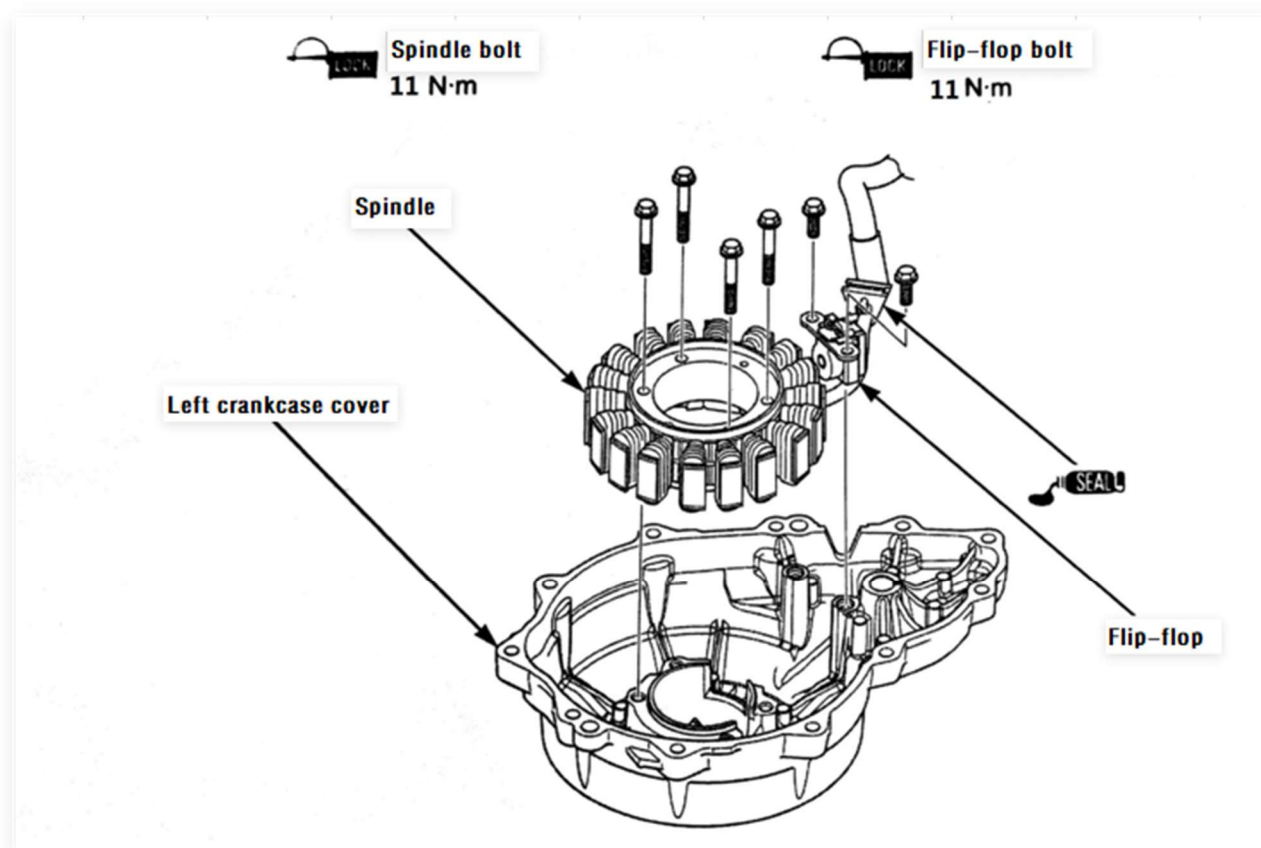

Rotor of magneto

Removal

Remove left crankcase cover.
Remove double gear shaft [1] and the gear [2].

Fix rotor [1] of magneto by its fixter,
then remove bolt [2].

Caution:

*Install a fixing piece for rotor fixter
to prevent its turning.*

Remove bolt of rotor and washer [5].

Remove rotor [1] by tool.

Tool:

[2] Rotor remover

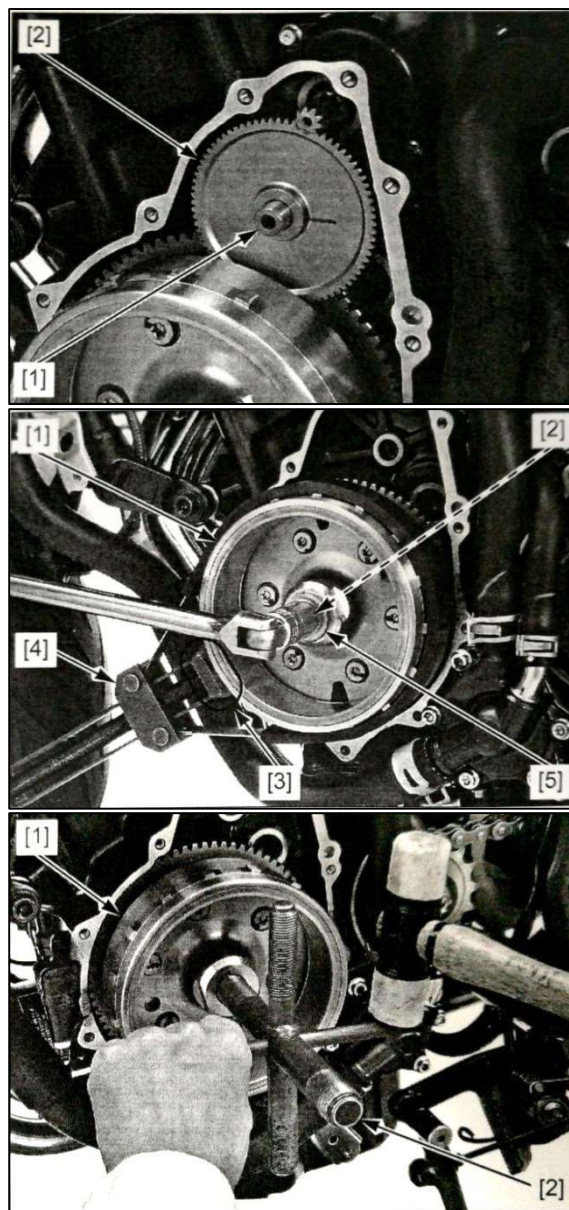

Remove semi-round key [1].
Please don't damage groove of semi-round key and crankshaft.

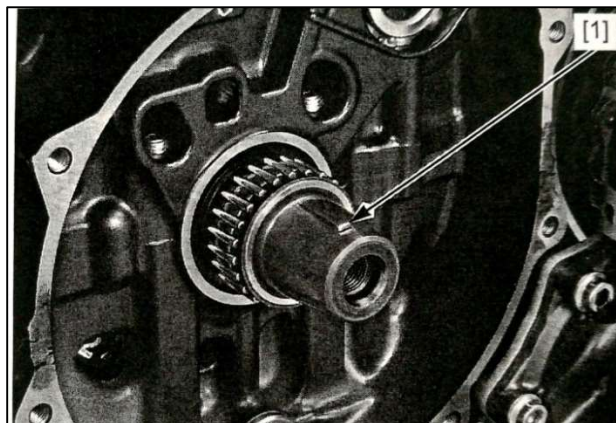

Inspection

Check if there is scratch, damage, wear-out and distortion on parts below, please replace if it is necessary.

- Double gear shaft
- Double gear
- Semi-round key
- Needle bearing

Re-assembly

Assemble semi-round key [1].

Coat rolling area of needle bearing [2] with engine oil.

Please don't damage groove of semi-round key and crankshaft.

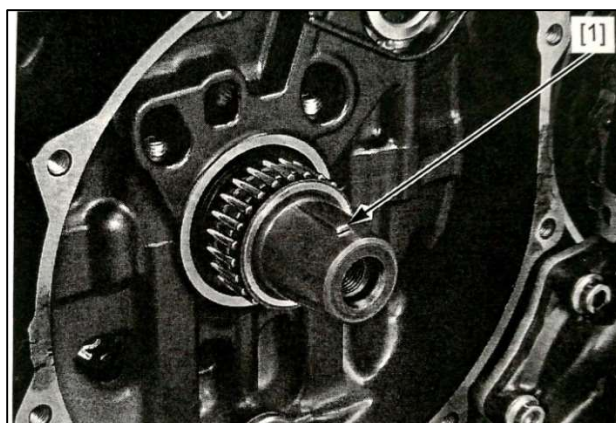

Totally clean up oil on conical surface of crankshaft and internal hole of rotor.

Re-assemble rotor {1}, please align semi-round key on crankshaft to its groove on rotor.

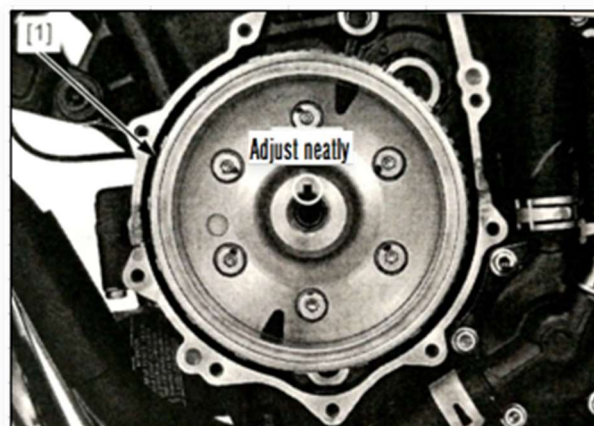

Coat threaded and installation surface of bolt for rotor with clean engine oil.

Assemble shim [1] and bolt [2] for rotor.

Fix rotor [1] by magneto fixer and fasten bolt to given torque.

Caution:

Install a fixing piece of rotor fixer to prevent turning.

Torque: 135N.m

Coat external surface of double gear shaft with solution of molybdenum disulfide.

Assemble double gear [1] and its shaft [2].

Assemble left crankcase cover.

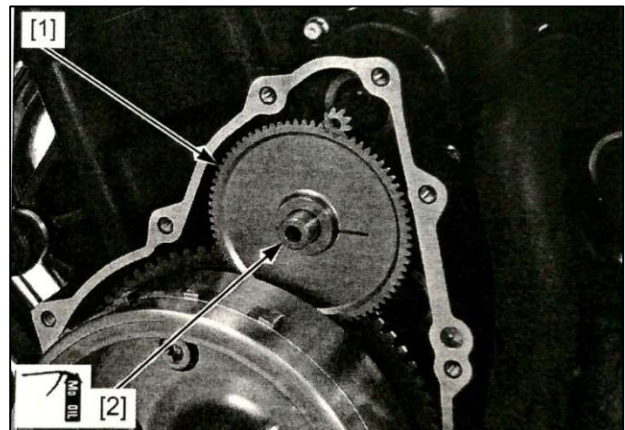
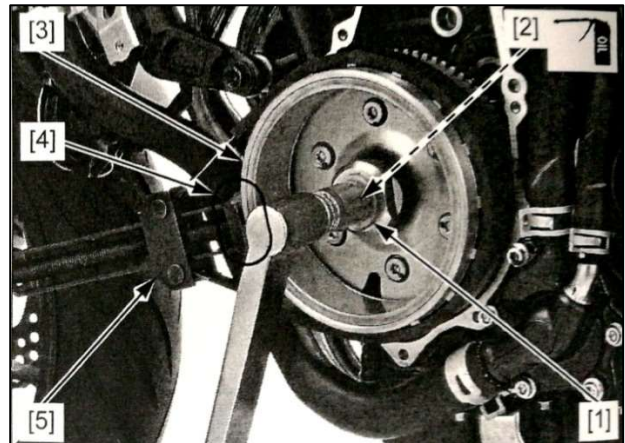

Starting clutch

Inspection for operation of starting clutch

Remove rotor.

Check operational performance of starting clutch by turning plate-shaped gear.

Check and confirm plate-shaped gear turning of anticlockwise while without clockwise turning.

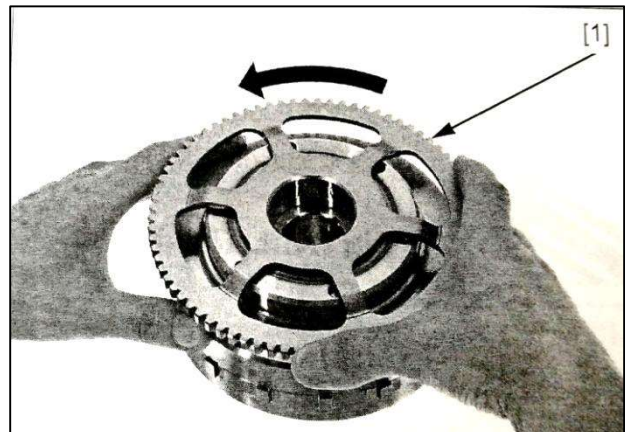

Removal

Remove rotor.

Remove plate-shaped gear [1] by turning anti-clockwise.

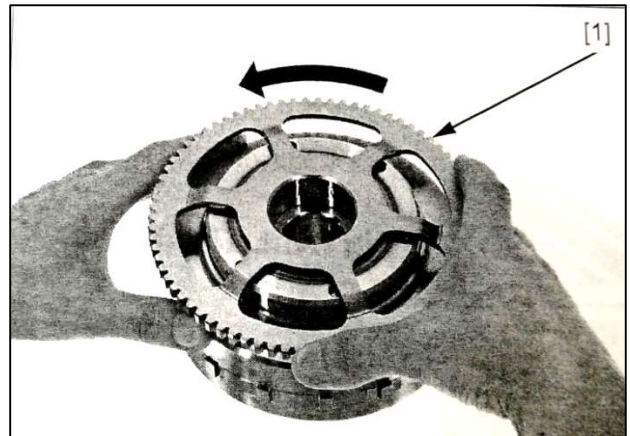

Fix rotor [1] of magneto by its fixer, then remove fastening bolt [2] of starting clutch.

Caution:

Install a fixing piece [4] for rotor fixer [3] to avoid rotor turning.

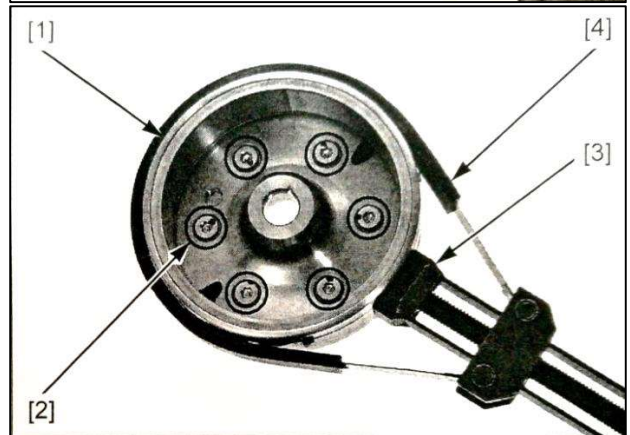

Remove starting clutch kit.

Remove starting clutch [2] from its outer case [1].

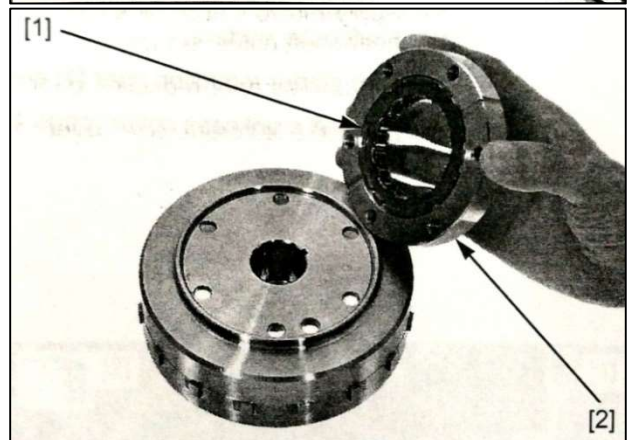

Inspection

Check if there is scratch, damage, wear-out and distortion on parts below. Please replace if it is necessary.

- Plate-shaped gear
- Outer case of clutch
- Starting clutch

Make sure each part meets demand of specification for magneto and starting clutch. Replace component in case it passed maintenance limit.

Re-assembly

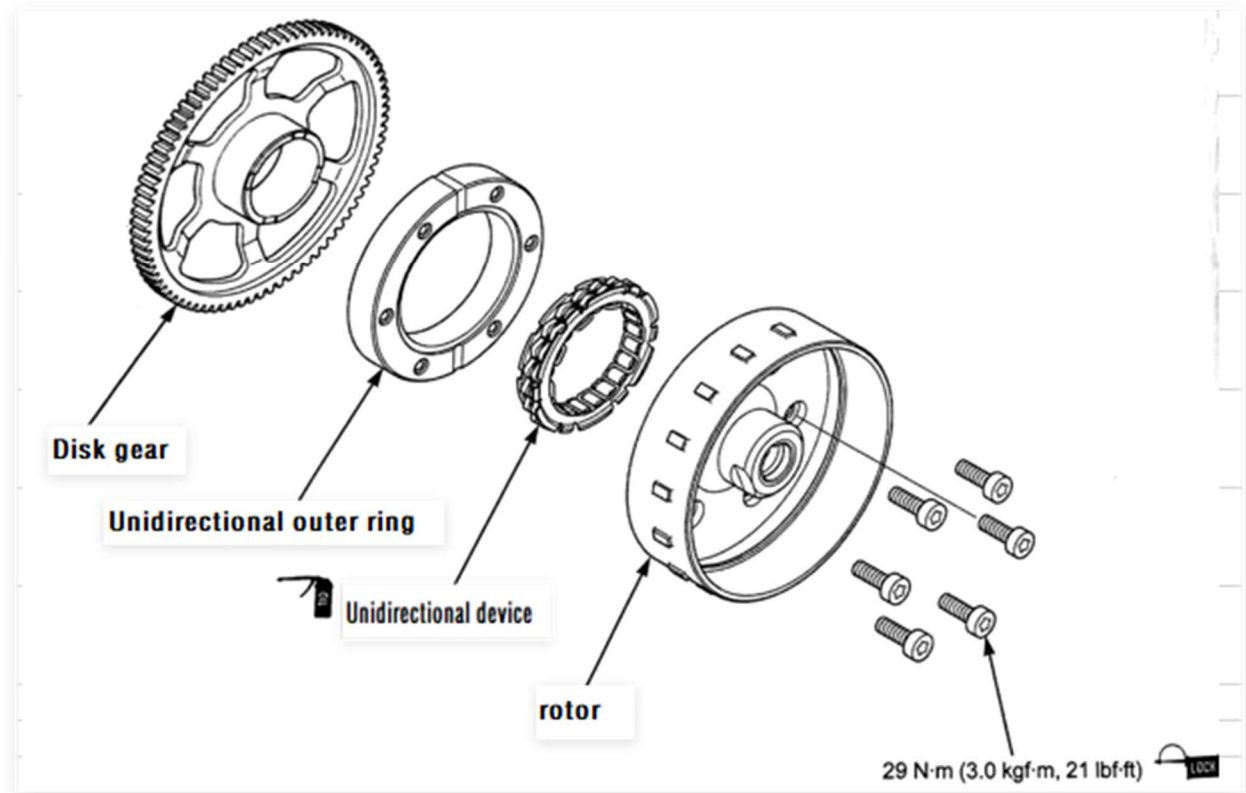

Coat contact surface of starting clutch with clean engine oil.

Assemble starting clutch [1] to its outer case [2].

Assemble starting clutch kit to rotor [3].

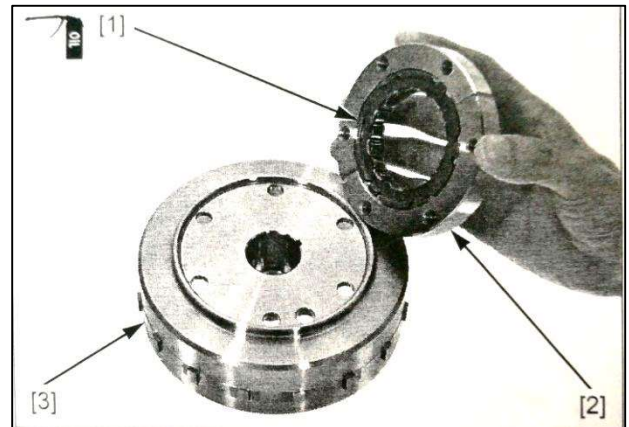

Fix rotor by its fixter [1].

Caution:

- *Install a fixing piece [3] for rotor fixter [2] to avoid rotor turning.*

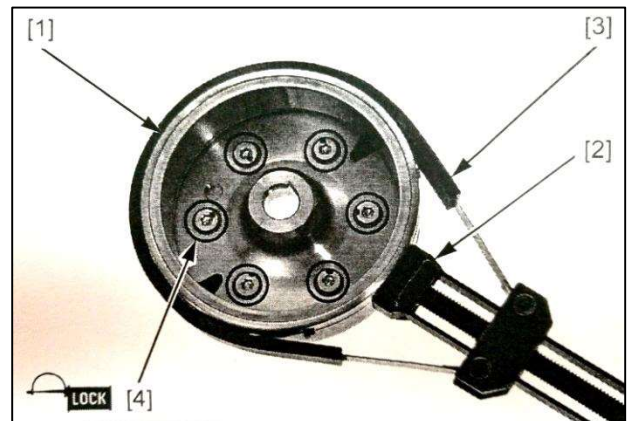

- *Align oil groove on clutch to oil hole on rotor.*

Coat threaded part of fastening bolt for clutch with Loctite.

Assemble and turn fastening bolt [4] to given torque.

Torque: 28N.m

Turn plate-shaped gear [1] anti-clockwise, then assemble the gear onto outer case of starting clutch.

Check operational performance for starting clutch.

Assemble rotor.

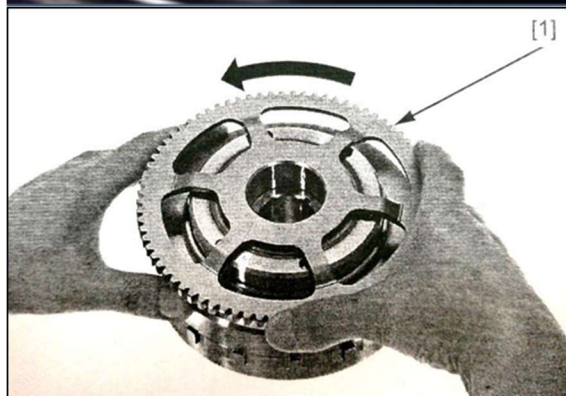

8 Case body and transmission system

Maintenance information

Summary

- Break up the crankcase for the maintenance below:
 1. Transmission system
 2. Crankshaft
 3. Balancing shaft
 4. Piston, connective rod and cylinder body
- Remove the parts below before breaking up crankcase:
 1. Engine
 2. Gearshift device
 3. Magneto kit
 4. Cylinder head kit
 5. Tensioner
 6. Tensioning and guiding plate
 7. Primary oil filter
 8. Pressure relief valve
 9. Secondary oil filter
 10. Heat exchanger for oil and water
 11. Water pump
 12. Water tube
 13. Oil pressure sensor
 14. Speed sensor
 15. Gear indicator kit
- Please don't damage the combination surface of crankcase when repairing.
- Wash and clean the oil passage before re-assembling the crankcase.
- Before combining the case, coat the combination surface with sealant for end surface evenly, the surplus sealant must be clean up.
- Mark up the pad on bigger end of connecting rod and that on main shaft with suitable color, select the shaft pad according to the requirement in its <Selection Table>, check the oil gap when shaft pads re-assembled, wrong oil gap may heavily damage the engine.

Tool(S):

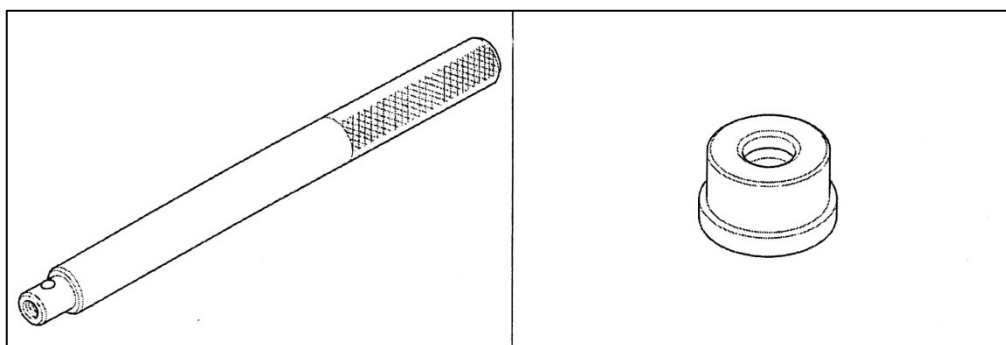

Specification for case body and transmission system

Unit: mm

Items			Standard	Maintenance limit
Transmission device	Internal hole diameter for gear	M5	28.000-28.021	28.04
		C1	24.007-24.028	24.04
		C2	31.000-31.025	31.04
	External diameter for shaft sleeve	M5, M6	27.959-27.980	27.94
		C2	30.970-30.995	30.94
		C3, C4	30.950-30.975	30.93
	Clearance between gear and shaft sleeve	M5	0.020-0.062	0.10
		C2	0.005-0.055	0.07
	Internal diameter of shaft sleeve	M5	25.000-25.021	25.04
		C2	28.000-28.021	28.04
Main shaft diameter	Matching up with shaft sleeve M5	24.967-24.980	24.96	
	Matching up with shaft sleeve C2	27.967-27.980	27.95	
Clearance between shaft and its sleeve	M5, C2	0.020-0.054	0.07	
Turning fork and its shaft	Diameter for turning fork shaft		11.957-11.968	11.95
	Internal diameter for turning fork		12.000-12.018	12.03
	Thickness for fork tip		5.93-6.00	5.9

Troubleshooting

Difficult gearshift

- Wrong operation on clutch
- Wrong viscosity of oil
- Gearshift fork got distorted
- Gearshift's shaft got distorted
- Ratchet of gearshift's fork got distorted
- Guiding groove on gearshift drum got damaged
- Gearshift arm got distorted

Gear jump in transmission system

- Gear got worn out
- Guiding groove of gearshift drum got worn out
- Gearshift fork's shaft got distorted
- Gearshift drum got damaged
- Twist spring of locating plate got damaged
- Gearshift fork got worn out or distorted
- Gearshift arm got damaged

Noisy engine

- Transmission gear got worn out or damaged
- Transmission bearing got worn out or damaged

Components layout

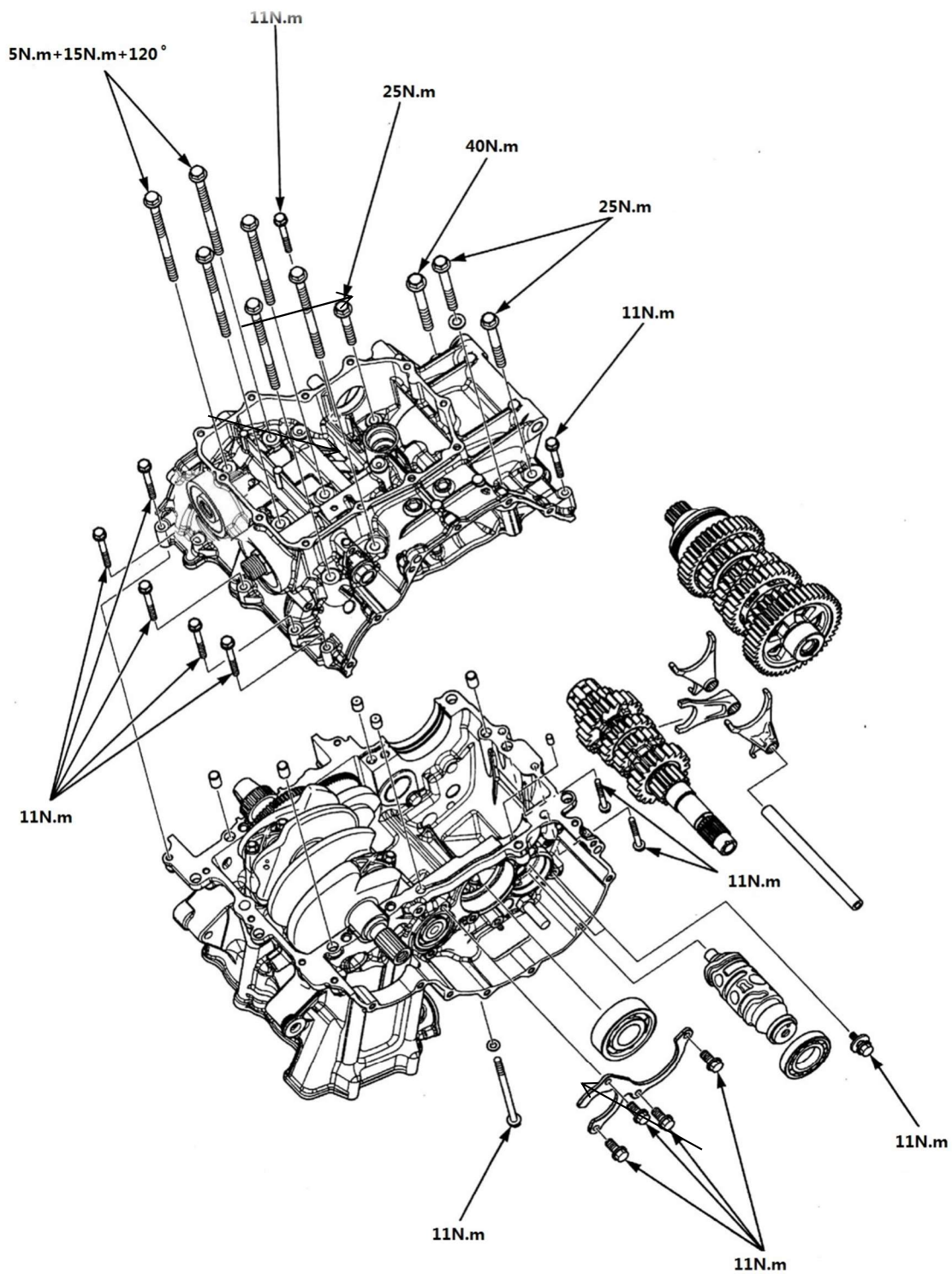

Transmission system

Disassembly

Remove bolt [1] on case body and the shim [2].

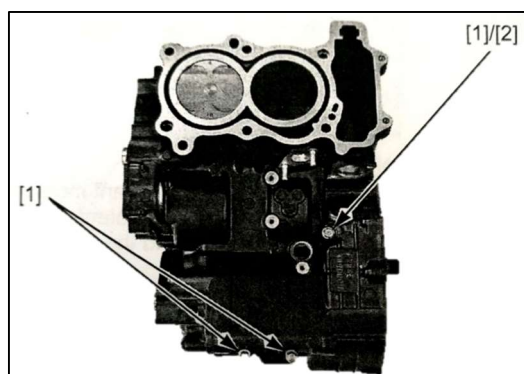

Put engine upside down.

Loosen bolt [1] of M10 on case body by 2 or 3 times, then bolt [2] M8×75, bolt [3] M8×55 and bolt [4] of M6, then remove all bolt and flat washer [5].

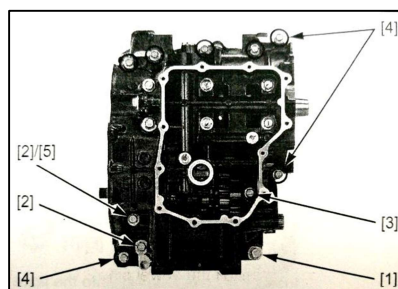

Loosen main shaft bolt [1] on case body then remove the bolt.

Remove lower crankcase body [2] from upper one.

Caution:

Please don't pry up contact surface of crankcase by screwdriver.

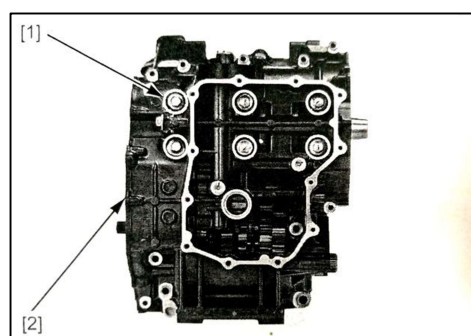

Remove positioning pin [1] and plug [2] for oil passage.

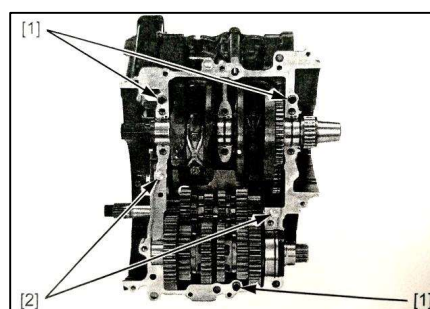

Re-assembly

Wash contact surface between upper and lower crankcase body, please don't damage contact surface.

Check if the oil passage blocked up, wash oil passage in case it is necessary.

Evenly coat lower case body with sealant for end surface as picture on the right shows.

Caution:

- Too much sealant is not allowed.
- Please don't let sealant cover bolt place of main shaft journal and that of oil passage.

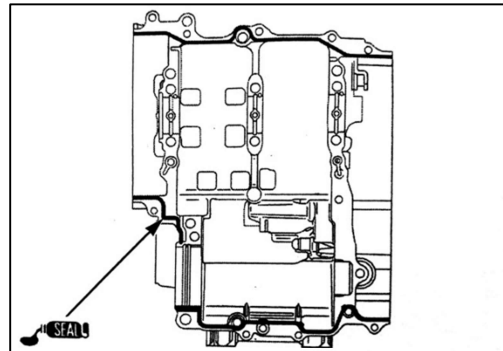

sealant for end surface.

Wash plug for oil passage.

Check and confirm if the plug for oil passage blocked up, replace the plug when it is necessary.

Assemble plug [1] of oil passage onto upper crankcase body [2], put the side with bigger hole diameter into upper crankcase body.

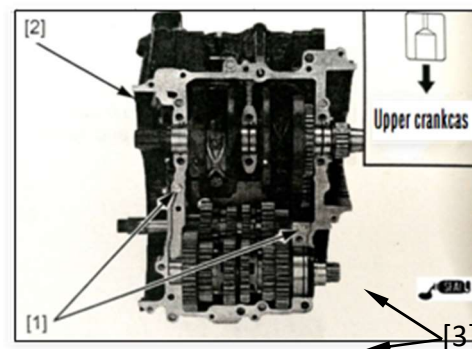

Coat contact place [3] between countershaft oil seal and upper case body with

Assemble positioning pin [1] into upper crankcase body [2].

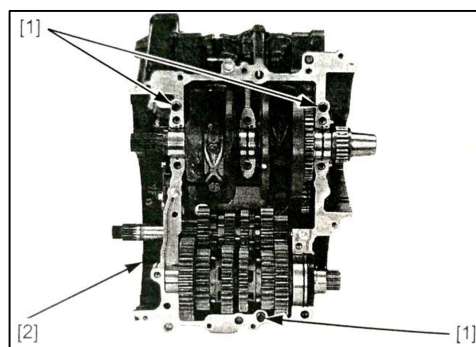

Coat shaft pad [1] of journal of main shaft in both upper and lower crankcase body with oil.

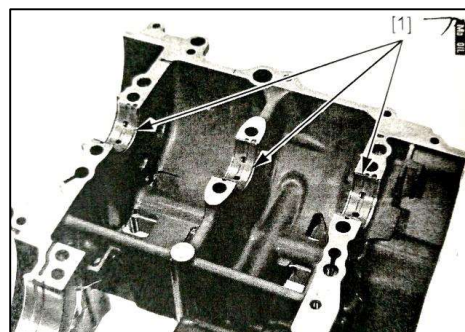

Assemble lower crankcase body [1] to the upper one.

Assemble new bolt [2] for main shaft journal.

Caution:

- Fasten bolts for main shaft journal in alternative way.
- Please don't adopt the used bolt for main shaft journal because its axial stress is already incorrect.
- Coat bolt for main shaft journal with oil before assembling to get its axial stretching ability stronger, please don't wipe up the oil when assembling.

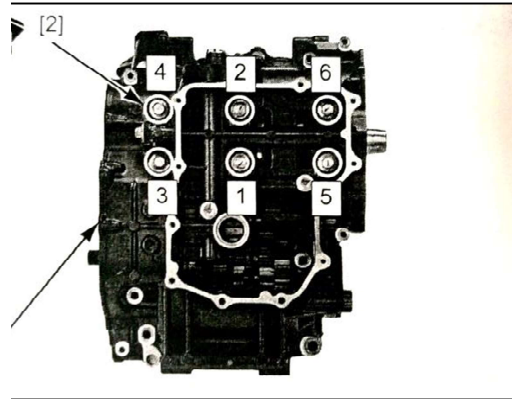

Confirm the upper and lower crankcase body are already firmly assembled.

Fasten bolts for main shaft journal by sequence and turning angle way as picture shows: 5Nm+15Nm+120°

Replace flat washer and case combination bolt for new ones.

Fasten case combination bolts to given torque by 2-3 steps.

Caution:

Assemble flat washer at place [1] in picture on the right.

Torque:

- M10 bolt [2]: 40N.m**
- M8×75 bolt [3]: 25N.m**
- M8×55 bolt [4]: 25N.m**
- M6 bolt [5]: 11N.m**

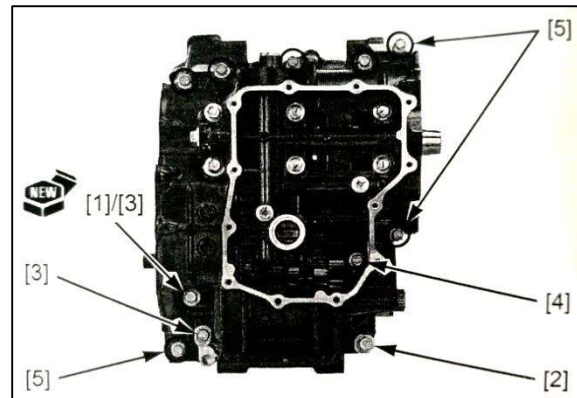

Put engine upside down and get its bottom face downwards.

Assemble new flat washer and case combination bolt M6.

Caution:

Assemble flat washer at place [1] in picture on the right.

Fasten bolt M6 to given torque.

Torque: 11N.m

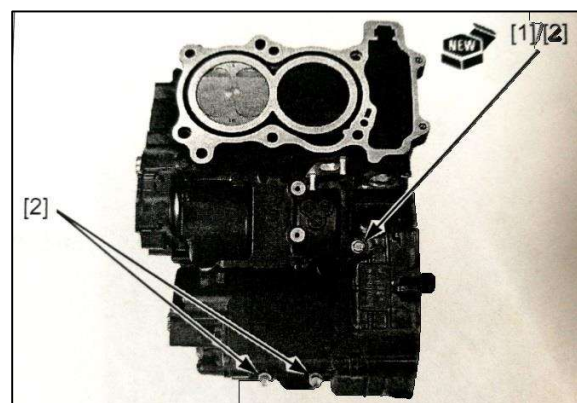

The re-assembly is opposite to disassembly.

Case body

Disassembly and re-assembly

Break up upper and lower crankcase body.
Align scale line [1] on gear of balancing gear to case combination surface of upper crankcase body while facing forward.

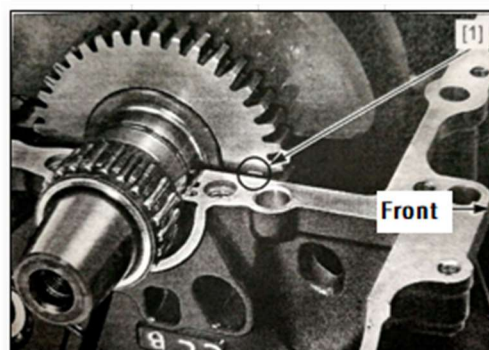

Remove countershaft kit [1] and pin shaft [2].

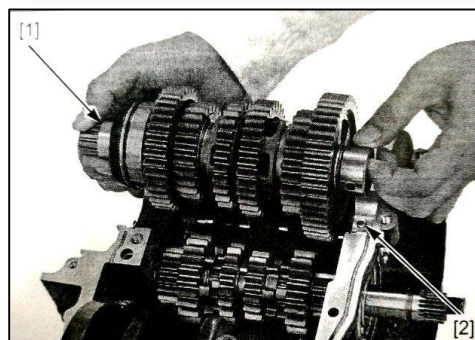

Remove limit bolt [1] for bearing of gearshift drum.

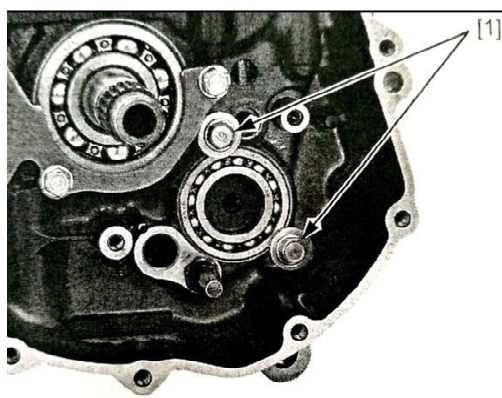

Remove turning fork shaft [1] and the fork [2].

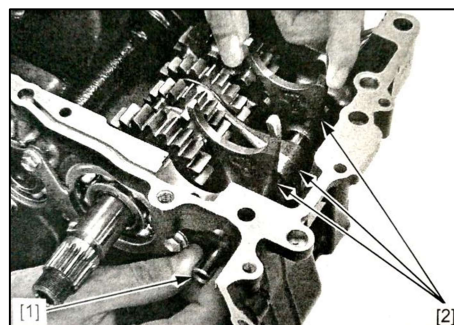

Remove gearshift drum [1] and its bearing [2].

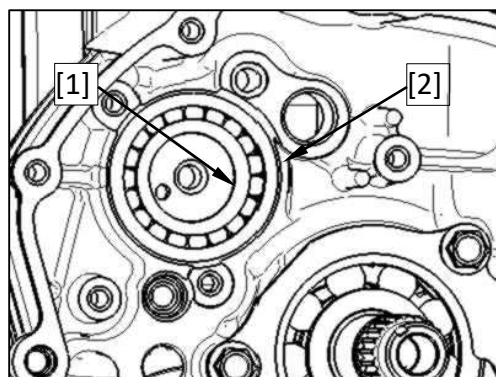

Remove bolt [1] and pressing plate [2] of main shaft bearing.

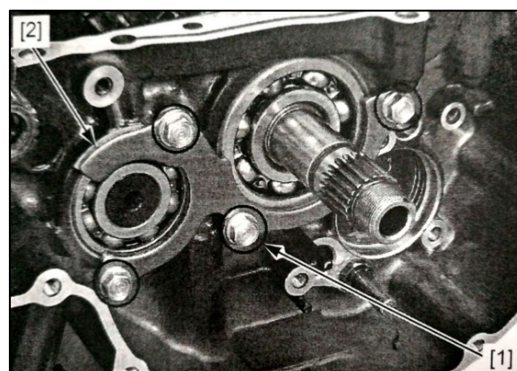

Slide main shaft kit on upper crankcase body and remove right side bearing of main shaft.

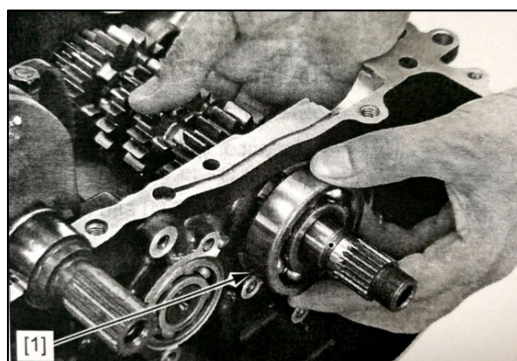

Remove main shaft kit.

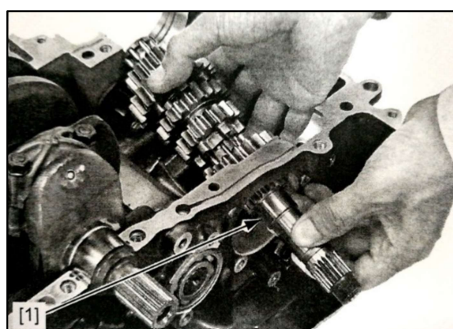

Break up main shaft and countershaft kit.

Caution:

- Put the removed gear, collar, washer and circlip in the container for them only in line.
- Please don't expand circlip beyond its limit, when removing circlip, expand it first, then push the circlip by gear behind it.



Inspection

Check and confirm if there is scratch, damage, wear-out and distortion on parts below, please replace if it is necessary.

- Transmission gear
- Transmission shaft sleeve
- Transmission bearing
- Gearshift drum/Gearshift drum's bearing
- Gearshift turning fork
- Turning fork shaft

Measure each part and calculate their matching clearance according to standard specification.

In case matching clearance passed

Replace outer ring of left side bearing for main shaft

Remove parts below:

- Balancing shaft
- Piston

Remove bolt [1] and check plate [2] for bearing.

Remove outer ring [3] for left side bearing of main shaft by tool for this

Knock left side bearing of main shaft into crankcase body in place by tool for this work only right above.

Tool:

- Extension bar
- Collar

standard limit, please replace the part.

work only.

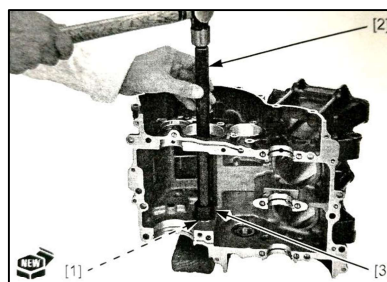
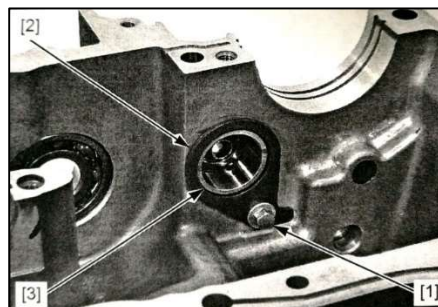

Coat threaded part of bolt for outer check plate of bearing base with Loctite.

Assemble outer check plate for outer bearing base, then fasten bolt to given torque.

Torque: 11N.m

Re-assemble the parts by opposite sequence to disassembly.

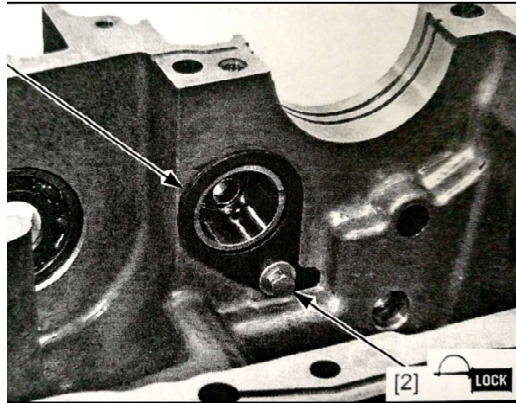

Re-assembly

Wash all the parts by solvent and totally dry them up.

Coat tooth surface, turning surface of gear and bearing place with oil.

Coat external surface of gear spline sleeve, overall surface of gear collar, turning area of needle bearing and groove of gearshift device with oil.

Re-assemble main shaft and counter shaft kit.

Caution:

- Coat each gear with oil and confirm its stable turning.
- Align inner spline of spline washer to its groove.
- When assembling thrust washer, make sure it is always along axial thrust surface
- Align opening gap to spline groove [1] when re-assembling circlip.
- When re-assembled, make sure it is completely assembled in shaft groove.

of gear.

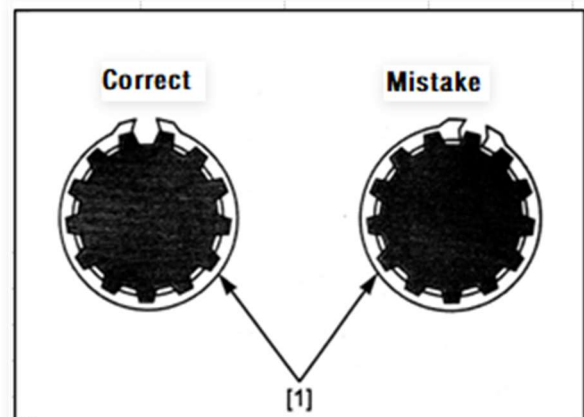

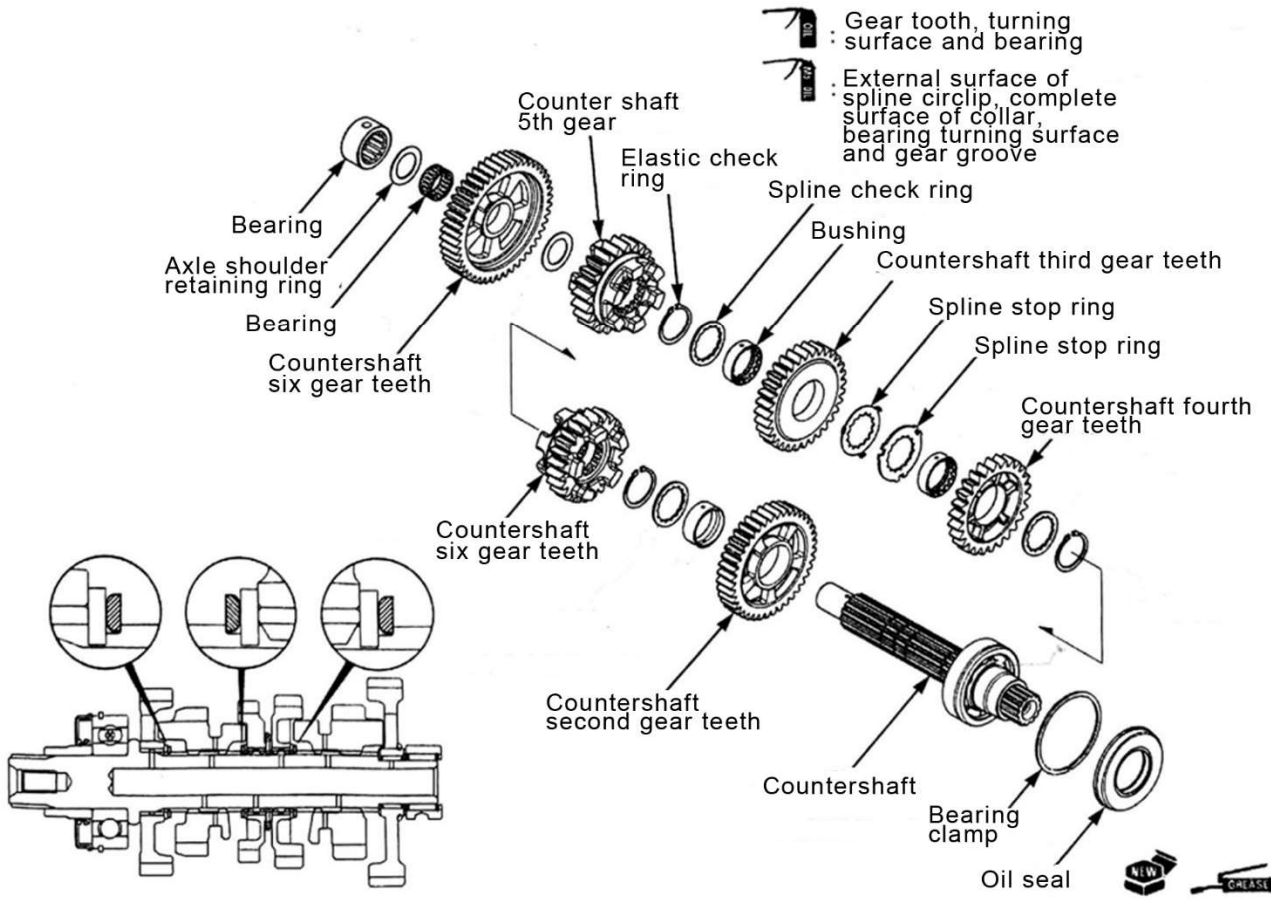
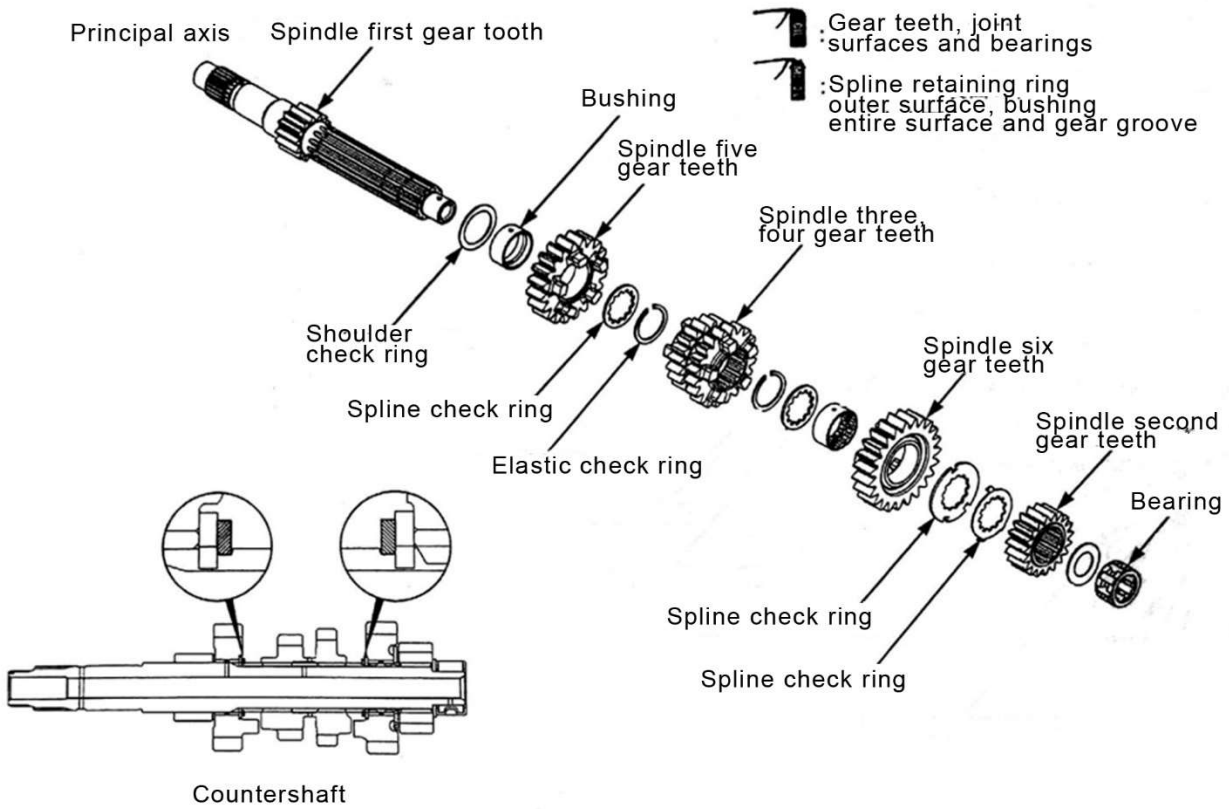

Re-assembly

Turn the crankshaft and get scale line [1] on driving gear of balancing shaft aligned to combination surface of crankcase while facing forward.

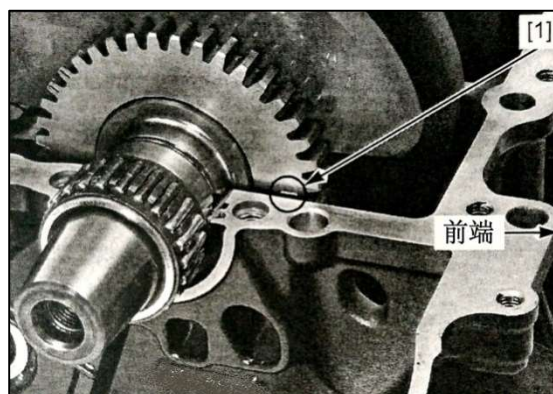

Assemble main shaft kit [1] into upper crankcase body.

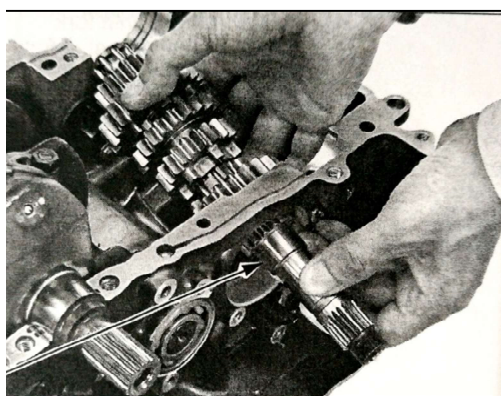

Coat right side bearing of main shaft with oil, then assemble the bearing [1] into upper crankcase body, please get the side with mark facing outside when assembling right side bearing of main shaft.

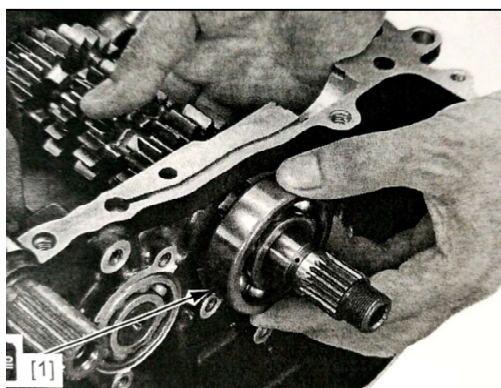

Re-assemble pressing plate [1] for main shaft bearing and bolt [2], before assembling, coat the threaded part of bolt with Loctite.

Fasten bolt to given torque.

Torque: 11N.m

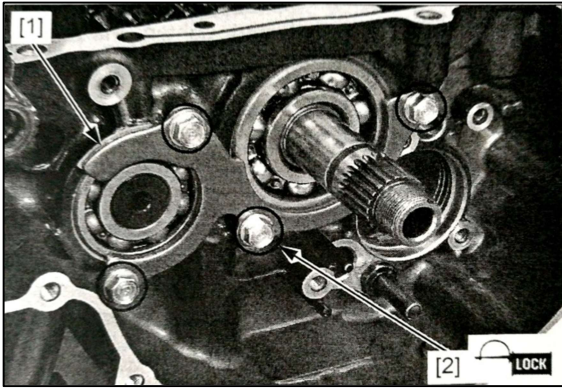

Coat external surface of gearshift drum and its bearing with oil.

Assemble bearing [1] of gearshift drum onto gearshift drum [2]. When assembling, get the side of bearing of gearshift drum with mark facing outside.

Assemble gearshift drum and its bearing kit onto upper crankcase body.

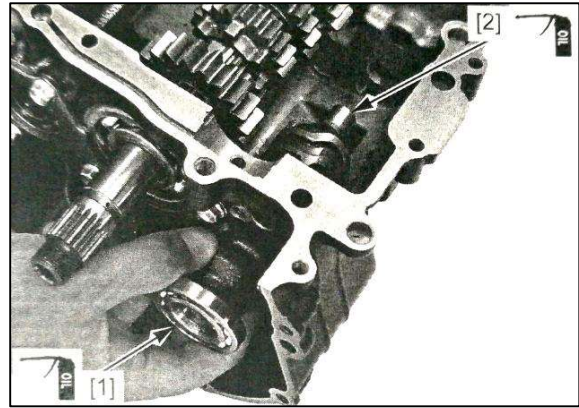

There are marks below on gearshift forks:

- “L” [1]: Left fork
- “C” [2]: Middle fork
- “R” [3]: Right fork

Coat guiding area of gearshift fork and place of guiding pin with oil.

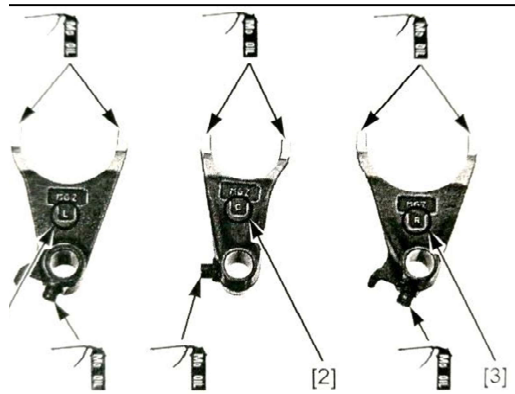

Coat surface of gearshift fork shaft with oil.

Assemble fork [1] onto guiding groove on gearshift drum and gearshift groove (Middle fork), and get its identifying mark facing to right side of engine, then insert fork shaft [2] in.

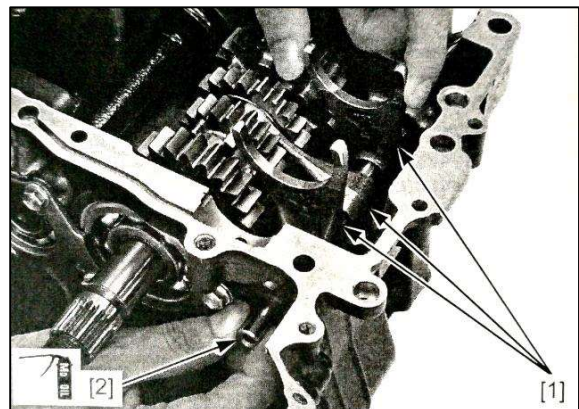

Coat threaded part of bolt for bearing washer of gearshift drum with Loctite.

Assemble bearing washer of gearshift drum and its bolt in place, then fasten bolt to given torque.

Torque: 11N.m

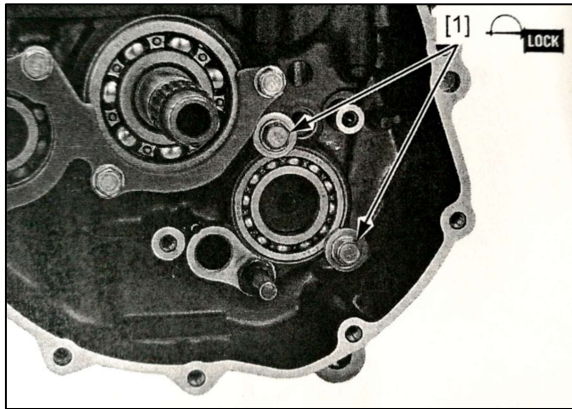

Assemble pillar pin into upper crankcase body.

Assemble countershaft onto upper crankcase body, when assembling, get oil seal and stopping ring into groove on case body, then align hole of outer ring for needle bearing to pillar pin.

Caution:

Make sure scale mark on needle bearing cover to combination surface of case body.

Assemble crankcase body.

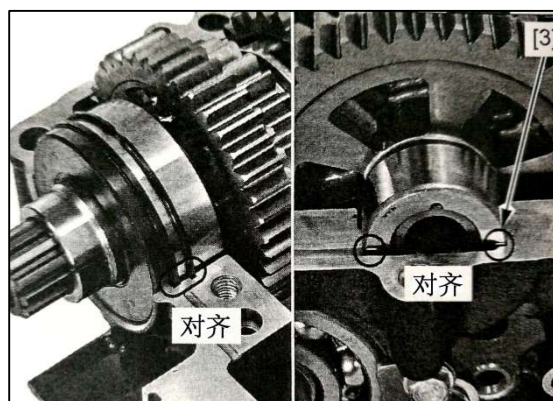
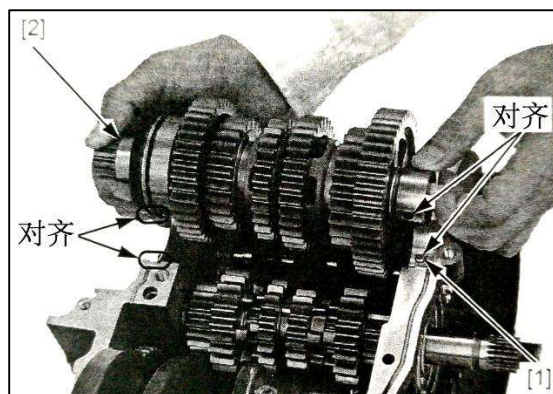

9 Crankshaft, piston, cylinder and balancing shaft

Maintenance information

Summary

When maintaining the crankshaft, balancing shaft, cylinder body, piston/connecting rod and nozzle, the crankcase must break up. How to break up the crankcase refer to its corresponding chapter.

Mark up the bigger end of connecting rod, cover of the rod and crankshaft pads and well put aside to make sure the correct re-assembly.

The crankshaft's pin and pad of main shaft's journal gets matched according to their color, select the crankshaft's pad according to its color. When the new pad selected, confirm the clearance of oil film by plastic feeler gauge, the wrong clearance of oil film may heavily damage the engine.

Tool(s):

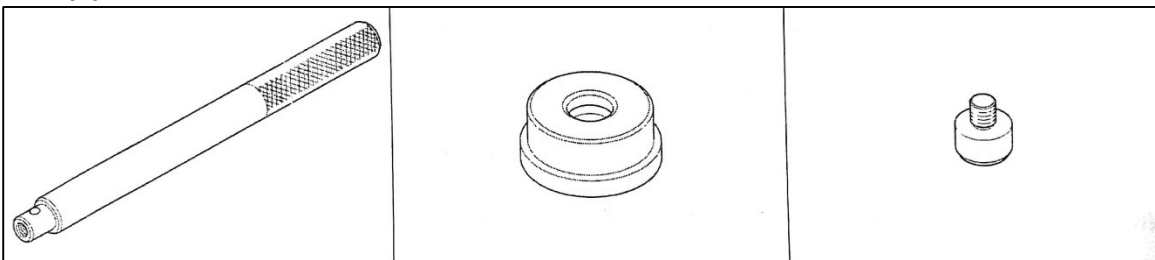

Specification for crankshaft, piston, cylinder body and balancing shaft

Unit: mm

Items		Standard	Limit	
Crankshaft	Clearance in bigger end of connecting rod	0.1-0.25	0.3	
	Clearance between pad on bigger end of connective rod and crankshaft pin	0.030-0.052	0.06	
	Clearance between journal of crankshaft and pad	0.018-0.036	0.05	
	Runout	—	0.03	
Cylinder	Cylinder bore	76.000-76.015	76.045	
	Roundness loss	—	0.10	
	Taper	—	0.10	
	Cylindricity	—	0.10	
Piston, piston pin and piston ring	Diameter for base circle of piston	75.965-75.980	75.915	
	Diameter of pin' s hole	17.002-17.008	17.018	
	Diameter for piston pin	16.994-17.000	16.984	
	Clearance between piston and piston pin	0.002-0.014	0.034	
	Closing clearance for piston ring	1 st ring	0.35	0.4
		2 nd ring	0.40	0.5
		Oil ring	1.0	1.0
	Clearance between piston ring and ring groove	Clearance between 1 st ring and groove	0.10	0.10
Clearance between 2 nd ring and groove		0.08	0.08	
Cylinder matching clearance		0.010-0.045	0.020-0.050	
Internal diameter of smaller end of connecting rod		16.030-16.044	17.013-17.025	
Matching clearance between connecting rod and crankshaft pin		0.03-0.05	0.013-0.031	

Troubleshooting

Too low the cylinder pressure, difficult starting or poor performance under low speed

- Air leakage of cylinder head's gasket
- Wear-out, jamming or damage on piston ring
- Cylinder head/Piston worn out or damaged

Too high the pressure in cylinder, cylinder body overheat or cylinder knocking

- Too much the carbon buildup on the top of piston

Too much waste gas

- Cylinder body, piston or its ring got worn out
- Wrong assembly for piston ring
- Scratch on piston or cylinder wall

Engine noisy

- Piston pin or the hole for pin got worn out
- Smaller end of connecting rod got worn out
- Cylinder body, piston or its ring got worn out
- Crankshaft pin's pad got worn out

Engine vibration

- Too strong the runout of crankshaft

Components layout

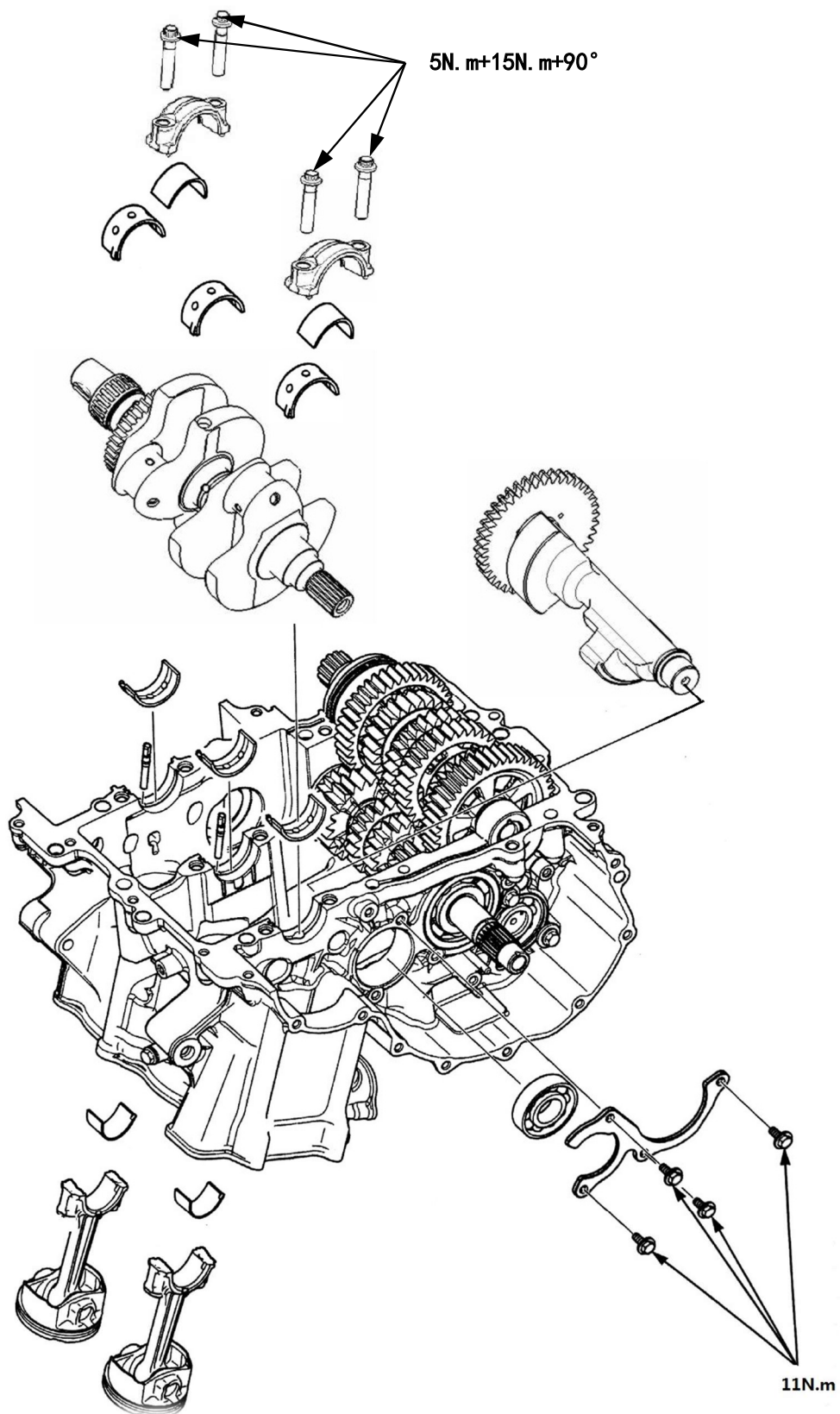

Crankshaft

Side clearance inspection

Break up upper and lower crankcase body.
Measure side clearance of connective rod.

Maintenance limit: 0.3mm.

In case clearance passed limit, please replace connective rod.

Confirm side clearance once again, in case still passed limit, please replace crankshaft.

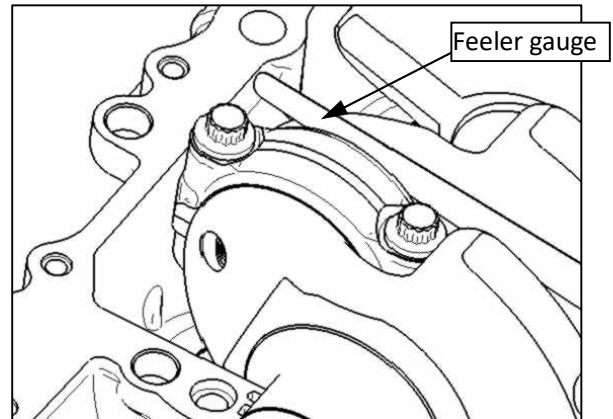

Removal

Caution:

Please don't change position of shaft pad, the shaft pad must be assembled in its initial position, otherwise it may break correct clearance for oil film and get engine damaged.

Break up upper and lower crankcase body.

Mark up connective rod cover and shaft pad before removing to ensure correct re-assembly.

Remove bolt [1] for connective rod and its cover [2]. Please avoid damage on crankshaft pin, main shaft journal and shaft pad.

In case connective rod cover is difficult to be removed, slightly knock side of cover. Remove crankshaft [3].

Caution:

Before removing crankshaft, push piston to upper stopping point to avoid damaging crankshaft pin.

Remove shaft pad [1] of main shaft journal 从 from upper and lower crankcase body.

Remove crankshaft pad [2] from bigger end of connective rod and its cover.

Caution:

Please don't change position of shaft

Remove 2 pieces of plug [1] for oil passage.

pad, the shaft pad must be assembled in its initial position, otherwise it may break correct clearance for oil film and get engine damaged.

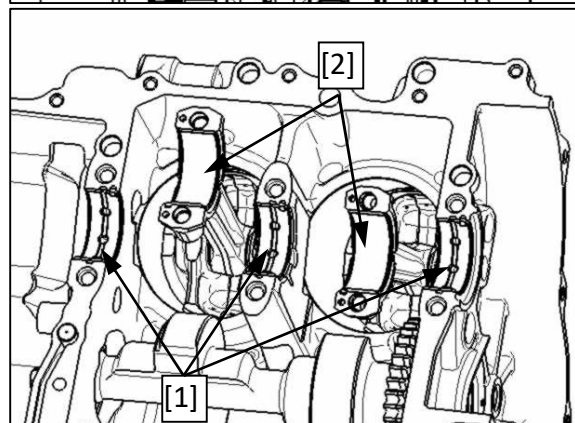
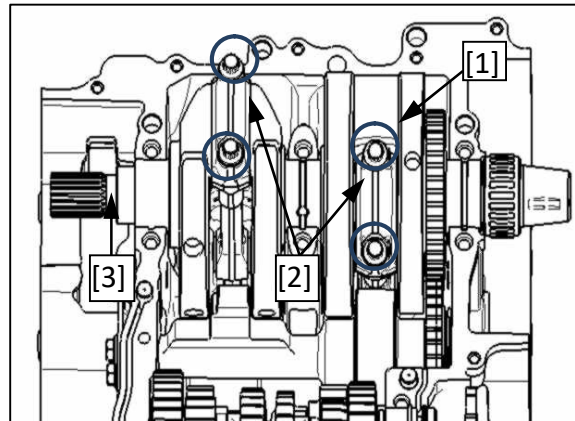

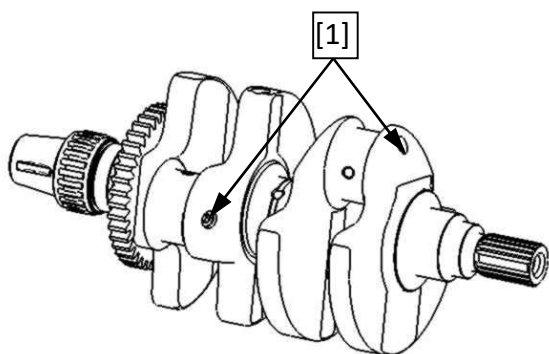

Inspection

Hold up crankshaft journal both sides.

Put a micrometer right above middle of main shaft journal, get it bypassing of oil groove and oil hole.

Turn crankshaft by 2 rounds (720°), read its runout.

Maintenance limit: 0.05 mm

Check damage or wear-out on driving gear [1] on balancing shaft.

Check if there is impurity in oil passage, clean it up in case there is.

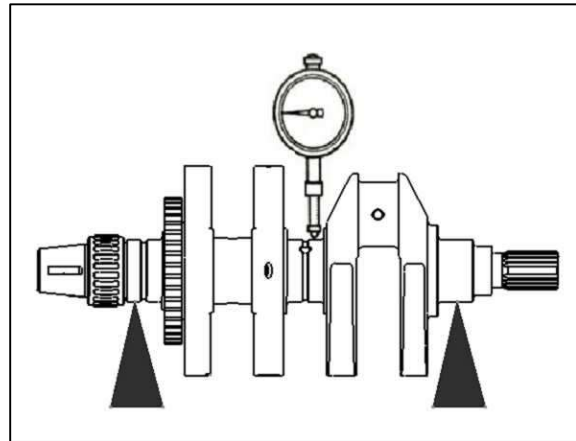

Re-assembly

Assemble 2 pieces of oil passage plug [1] onto crankshaft, coat them with suitable Locatite and avoid sealant getting into oil passage.

Torque: 8N.m

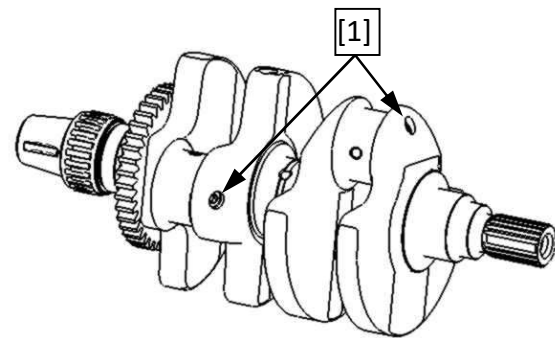

Assemble shaft pad [1] of main shaft journal and that [2] of crankshaft pin to their original place.

- Shaft pad for main shaft journal
- Shaft pad for crankshaft pin
- **Caution:**

Please don't change position of shaft pad, the shaft pad must be assembled in its initial position, otherwise it may break correct clearance for oil film and get engine damaged.

Coat internal surface of shaft pad for main shaft journal in upper crankcase and shaft pad of crankshaft pin in bigger end of connective rod with oil.

Align end of piston skirt to edge of cylinder body.

Coat thrust surface of crankshaft with oil as picture shows.

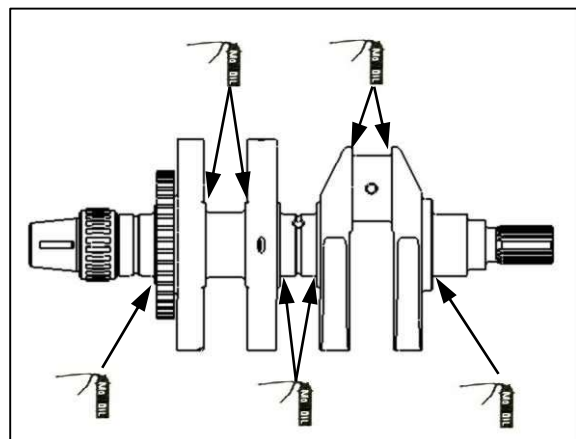
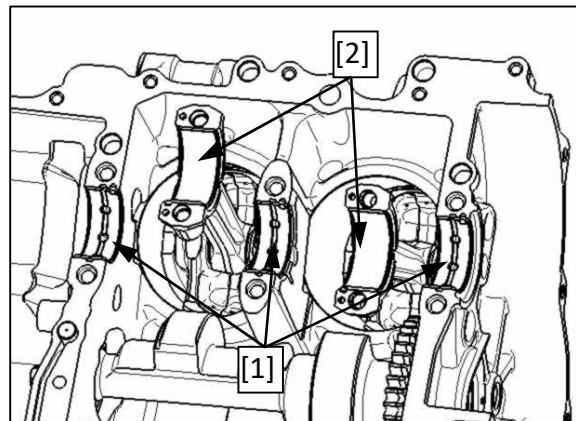

Assemble balancing shaft in, and align round hole on balancing shaft to that on case body

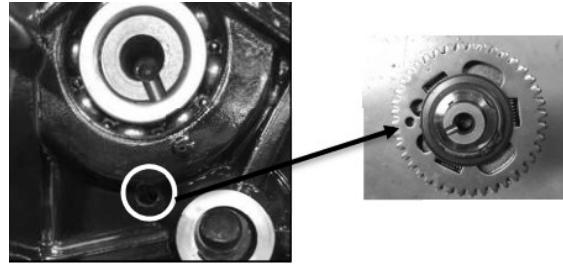

Insert tool $\Phi 5$ of round bar, fix balancing shaft and slightly swing it to confirm it already fixed its position

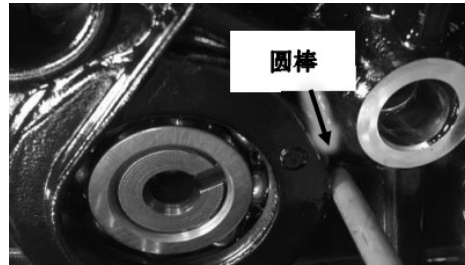

Assemble crankshaft [1] right above crankcase, the mark [2] “ Δ ” on driving gear of balancing shaft face to front side of engine and get aligned to contact surface of case body, then put crankshaft pin into bigger end of connective rod.

Caution:

Please don't damage crankshaft pin, journal of main shaft and shaft pad.

Assemble crankshaft into upper crankcase.

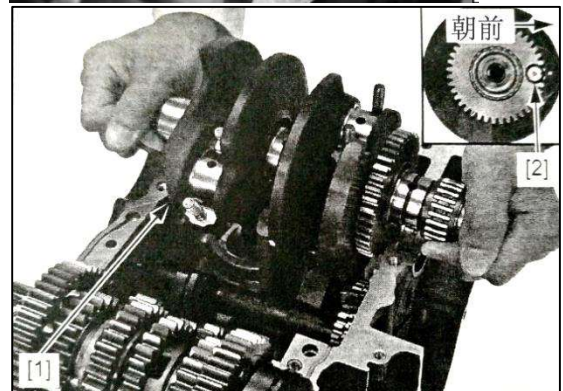

Put bigger end [1] of connective rod into crankshaft pin.

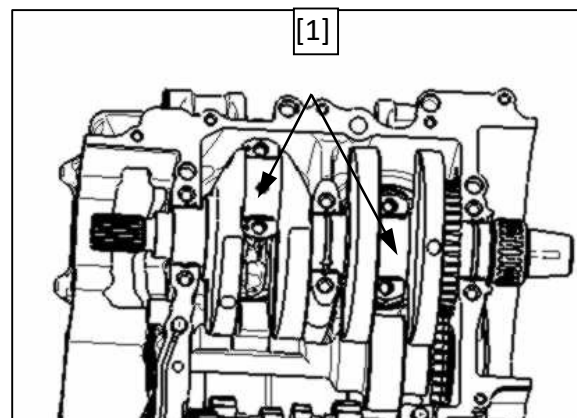

Clean up contact surface between bigger end of connective rod and rod cover, then dry it up by compressed air.



Coat internal surface of crankshaft pad on cover of connective rod.

Assemble cover [1] of connective rod by matching up code number on connective rod cover and bigger end of rod.

Caution:

Make sure each parts are re-assembled to their original place as sign when they were removing.

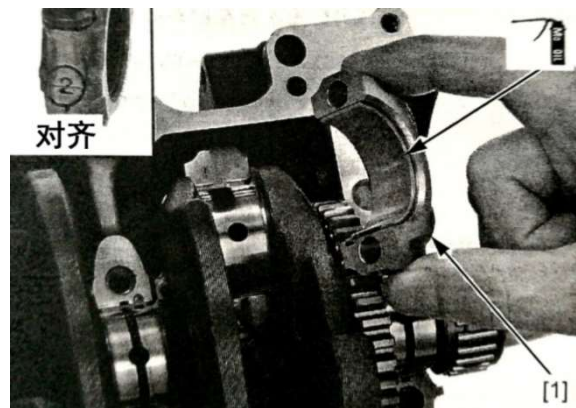

Coat threaded part and its base surface of connective rod with oil.

Assemble connective bolt [1] of connective rod and fasten to given torque by 3 times.

Torque: 5N.m+15N.m+90°

Assemble upper and lower crankcase.

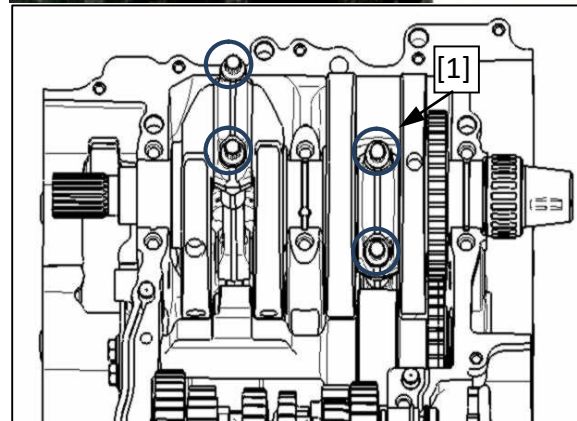

Shaft pad of journal for main shaft

Caution:

Please don't change the position of shaft pad. The shaft pad must be assembled in its initial position, otherwise the oil film clearance will be wrong, which lead to engine damage. ◦

Inspection for shaft pad

Remove crankshaft. (Page 120)

Check if there is wear-out or spalling of shaft pad [1] for journal of main shaft.

Check if there is damage on protrusion [2] of shaft pad.

In case there is damage on shaft pad for journal of main shaft, please choose the correct one for replacement.

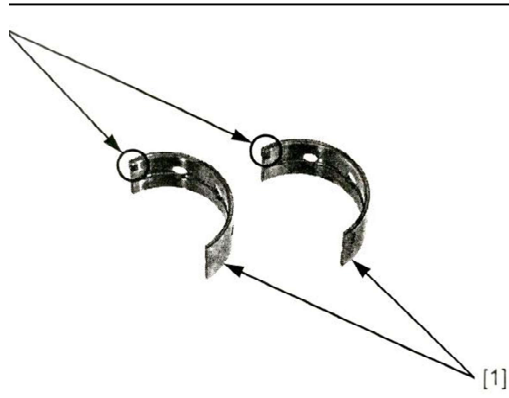

Inspection for oil clearance

Remove crankshaft.

Wipe up all the oil on shaft pad and journal of main shaft.

Re-assemble main shaft into upper crankcase.

Put a plastic gap gauge [1] on each journal of main shaft bypassing oil hole. (During the inspection of oil clearance, please don't turn the crankshaft).

Assemble positioning pin [1] into upper crankcase [2].

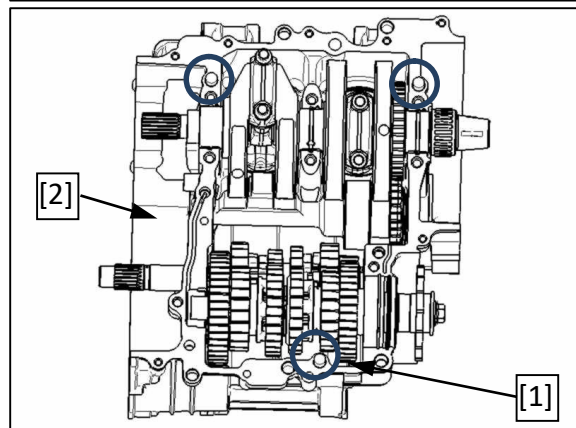
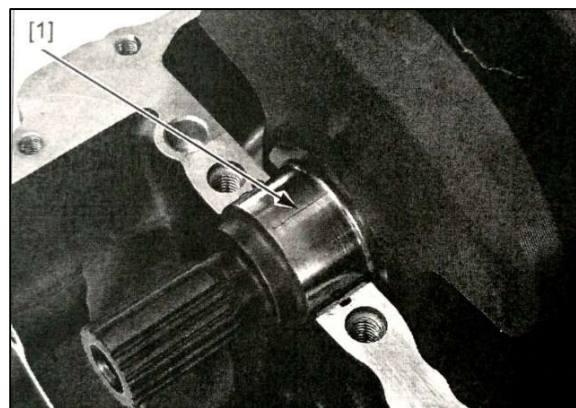

Re-assemble lower crankcase [1] onto upper crankcase.

Wash case combination bolt by cleanser (Repeatedly use), then totally dry it up by blowing.

Coat threaded part and base surface of case combination bolt for main shaft with oil.

Assemble case combination bolt [2] of mainshaft journal.

Make sure upper and lower crankcase are firmly assembled.

Fasten case combination bolt main shaft journal by 3 times according to code number

Remove case combination bolt of main shaft journal and lower crankcase.

Measure each widest width for plastic clearance gauge on main shaft journal when it was squeezed to confirm oil clearance.

Maintenance limit: 0.05 mm

In case oil clearance passed maintenance limit, select correct shaft pad for replacement.

showing in picture.

Torque: 5N.m +15N.m+120°

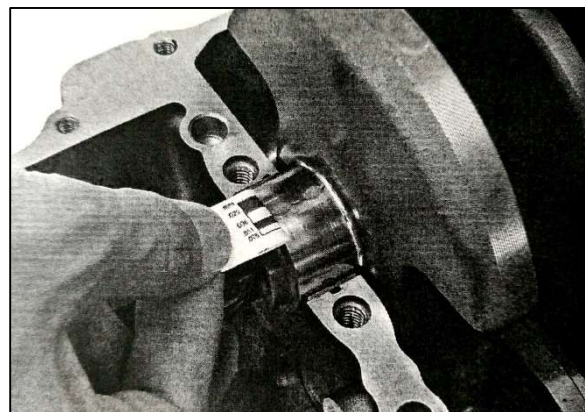
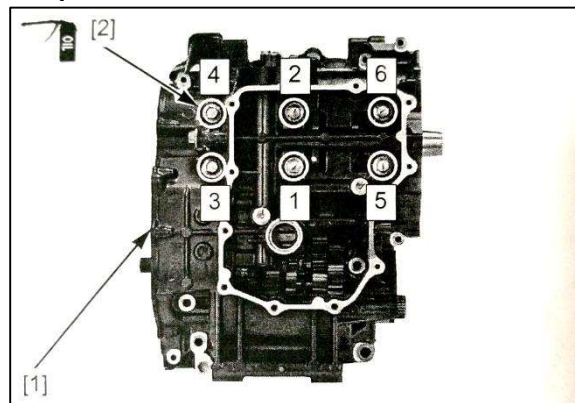

Shaft pad selection

Take the number [1] for inner diameter for installation hole of shaft pad on left side of upper crankcase into record. As picture shows (Number on left side of upper crankcase (A, B or C). Which means the number for inner diameter of installation hole for shaft pad from left to right).

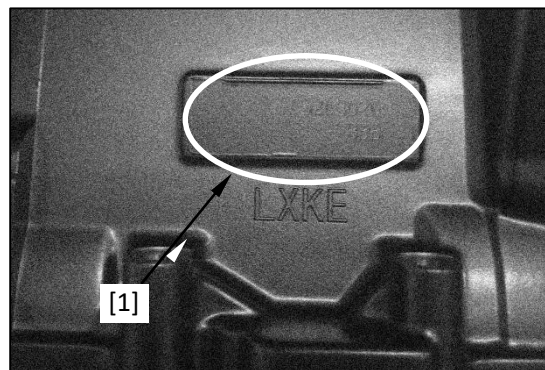

Choose shaft pad color [1] by mutual reference for code number between main shaft journal and shaft pad.

Thickness for shaft pad of main shaft journal:

- A: Black: Thick
- B: Brown: ↑
- C: Green: ↓
- D: Yellow: ↓
- E: Red: Thin

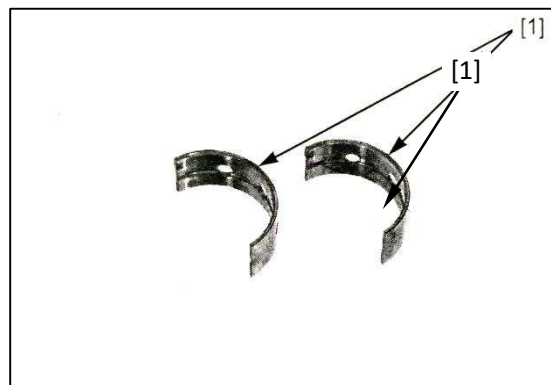

Form list for matching-up of journal for main shaft:

			Code number for inner installation hole of shaft pad		
			A	B	C
			$\phi 38.000 - \phi 38.006$ mm	$\phi 38.006 - \phi 38.012$ mm	$\phi 38.012 - \phi 38.018$ mm
Code number for outer diameter of main shaft journal	1	$\phi 35.000 - \phi 35.006$ mm	E (Red)	D (Yellow)	C (Green)
	2	$\phi 34.994 - \phi 35.000$ mm	D (Yellow)	C (Green)	B (Brown)
	3	$\phi 34.988 - \phi 34.994$ mm	C (Green)	B (Brown)	A (Black)

Caution:

When new shaft pad was chosen, please check clearance once again by plastic clearance gauge.

Re-assemble shaft pad

Clean up outer surface of shaft pad and installation hole for shaft pad on crankcase.

Re-assemble shaft pad [1] for journal of main shaft into its installation hole on crankcase, align each protrusion to groove.

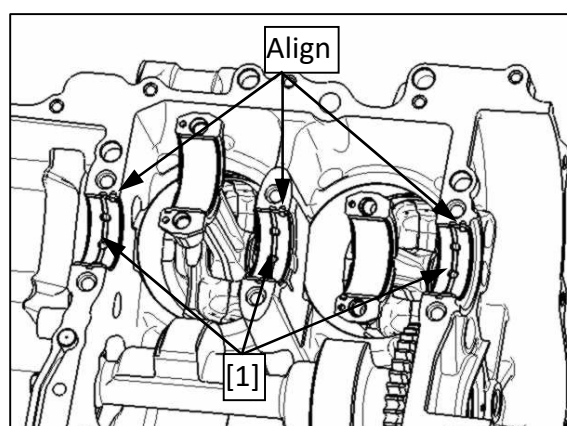

Shaft pad for crankshaft pin

Caution:

Please don't change the position of shaft pad. The shaft pad must be assembled in its initial position, otherwise the oil film clearance will be wrong, which lead to engine damage.

Remove crankshaft

Check if there is wear-out or spalling for shaft pad [1] of crankshaft pin.

Check if there is damage on protrusion [2] of shaft pad.

In case the shaft pad for crankshaft pin gets damaged, select shaft pad for replacement.

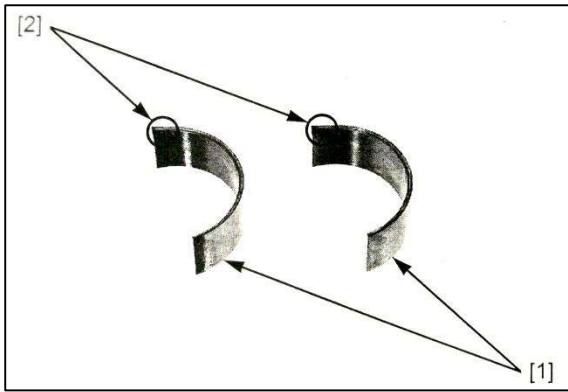

Check oil clearance

Remove crankshaft.

Wash contact surface between bigger end of connective rod and rod cover by cleanser, then dry it up by compressed air.

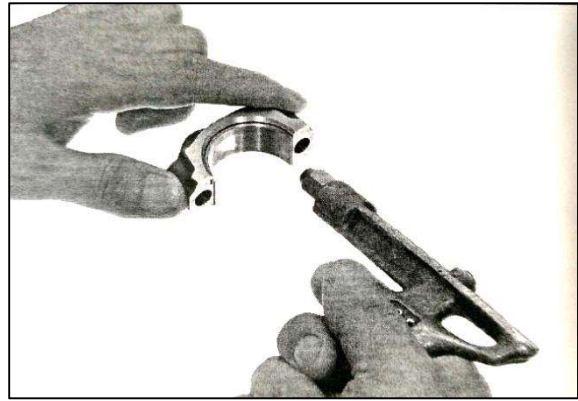

Wipe up all the oil on shaft pad and crank shaft pin.

Re-assemble crankshaft into upper crankcase. (Page 121)

Assemble bigger end of connective rod into crankshaft pin.

Vertically lay a plastic gap gauge [1] on each journal of main shaft bypassing oil hole (Please don't turn crankshaft during inspection for oil clearance)

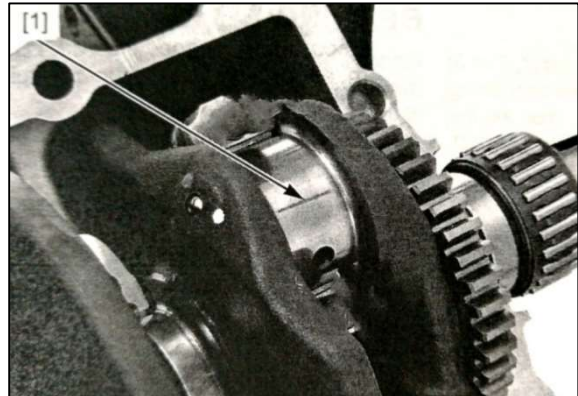

Assemble connective rod cover [1] by mutual reference for code number between the cover and bigger end of rod.

Caution:

Make sure each part is re-assembled back to initial position as the same to marking-up when removing

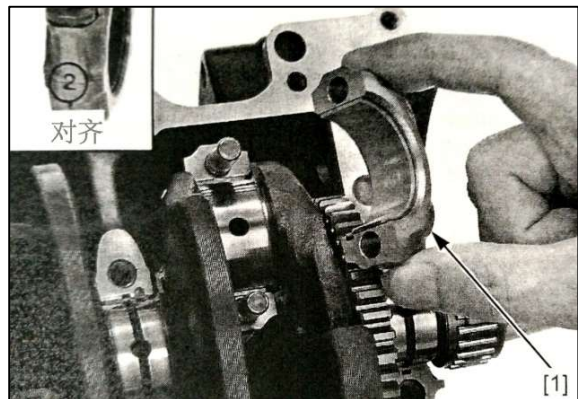

Coat threaded part of connective rod's bolt and its base surface with oil. Assemble connective rod's bolt [1] and fasten by 3 times.

Torque: 5N.m+15N.m+90°

Remove cover of connective rod.

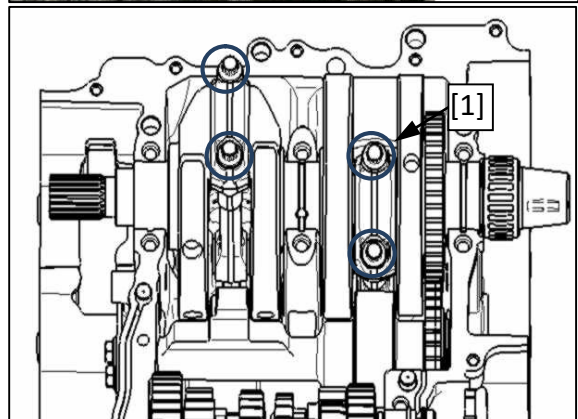

Measure each squeezed widest width of plastic gap gauge on crankshaft pin to confirm the oil clearance.

Maintenance limit: 0.06mm

In case the oil clearance passed maintenance Limit, please choose the correct shaft pad for replacement.

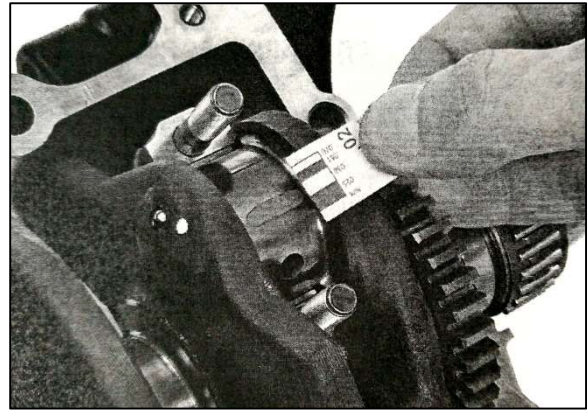

Selection for shaft oad

Take number [1] at inner diameter for connective rod cover into record (The number on bigger end of connective rod (1, 2 or 3) means the number for inner diameter for bigger end of connective rod), or assemble the cover onto connective rod, measure inner diameter without shaft pad.

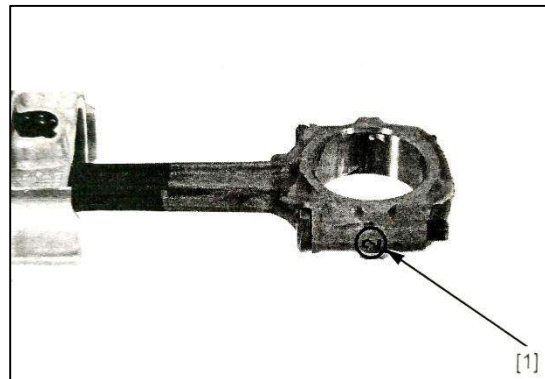

Choose color [1] for replaceable shaft pad by mutual reference for code number between bigger connective rod and crankshaft pin.

Thickness for shaft pad of crankshaft pin:

- A: Blue: Thick
- B: Black: ↑
- C: Brown: ↓
- D: Green:
- E: Yellow: Thin



Mathcing-up form list for shaft pad of crankshaft pin:

			Code number for inner diameter for bigger end of connective rod		
			1	2	3
			φ 40.000- φ 40.006 mm	φ 39.006- φ 39.012 mm	φ 39.012- φ 39.018 mm
Code number for outer diameter for crankshaft pin	A	φ 36.994- φ 37.000 mm	E (Yellow)	D (Green)	C (Brown)
	B	φ 36.988- φ 36.994 mm	D (Green)	C (Brown)	B (Black)
	C	φ 36.982- φ 36.988 mm	C (Brown)	B (Black)	A (Blue)

Caution:

When new shaft pad was chosen, please check clearance once again by plastic gap gauge.

Re-assemble shaft pad

Clean up outer surface of shaft pad, connective rod cover and bigger end of rod. Re-assemble shaft pad [1] for crankshaft pin into bigger end of connective rod, align each protrusion to groove.

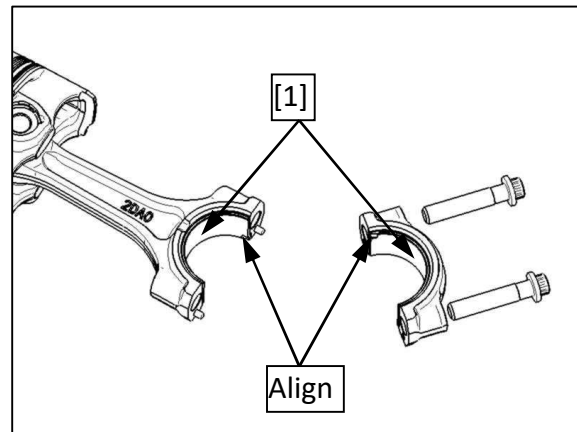

Piston/Cylinder body

Removal for piston/Connective rod kit

Caution:

Before removing piston, wrap bigger end of connective rod by a clean fiberless fabric to prevent damaging cylinder hole.

Please don't try to remove piston/connective rod kit from bottom of cylinder hole, which will be seized up at joint between cylinder sleeve and upper crankcase body.

Please don't change the position for shaft pad, the pad must be re-assembled back to initial position, otherwise the oil film clearance will be wrong, which lead to engine damage.

Remove the parts below:

- Balancing shaft
- Crankshaft

Remove piston/connective rod kit [1] from top

Removal for piston

Remove circlip [1] of steel wire by tweezers. Push out piston pin [2] from piston [3] and smaller end [4] of connective rod, then remove the piston.

of cylinder body.

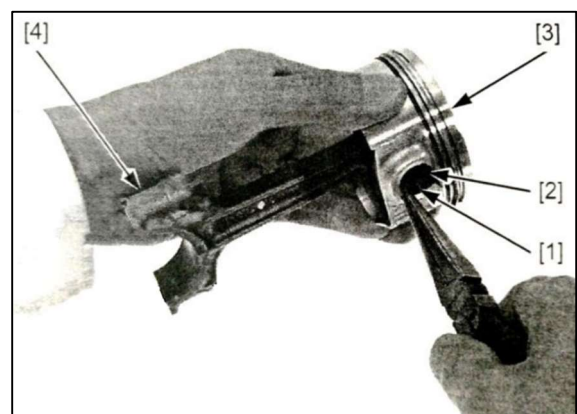
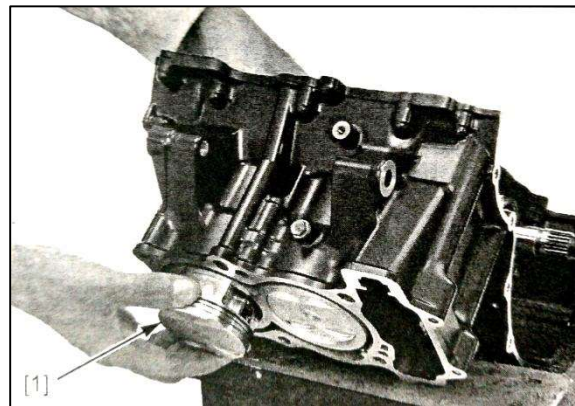

Removal for piston ring

Get opening for each piston ring apart, then remove the ring upwards along the opposite position to opening of piston ring.

Caution:

- Please don't separate the opening apart too far to prevent damaging the piston ring.
- Please avoid scratch on piston when removing its rings.

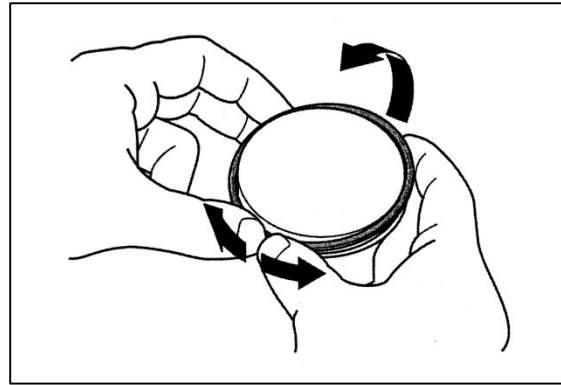

Clean up carbon buildup in groove of piston ring by piston ring which is about throwing away.

Caution:

Please don't use steel brush to avoid scratching groove of piston ring.

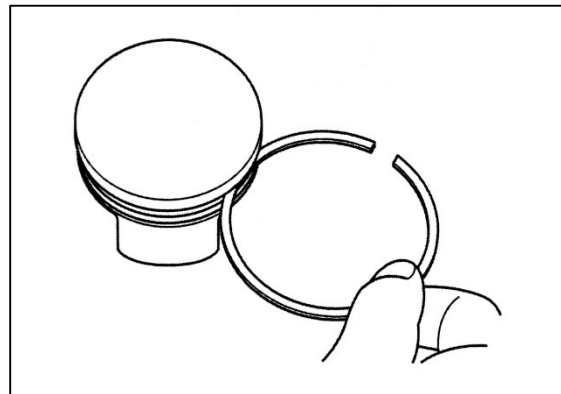

Inspection

Check if there is scratch, damage, wear-out, distortion, burn-out or oil passage blocking-up on parts below.

- Cylinder body
- Piston
- Piston ring
- Piston pin
- Smaller end of connective rod

Measure each parts according to Technical specification for crankshaft/piston/cylinder hole/balancing shaft and calculate their clearance.

Any parts passed maintenance limit must be replaced.

Re-assemble piston ring

Totally clean up groove of piston ring then re-assemble piston ring.

- Coat the complete surface of piston rings and their grooves with engine oil.。
- Please don't damage piston and its rings during re-assembling.
- When re-assembling, get the side of piston ring with mark facing upwards。
 - Mark “DY” : Ring 1st [1].
 - Mark “D” : Ring 2nd [2].
- When re-assembling oil ring [3], assemble liner ring [4] first, then the scratching ring [5].

Get mutual crossing angle for piston ring opening by 120° .

The dislocation for position of opening for scratching ring is shown as picture.

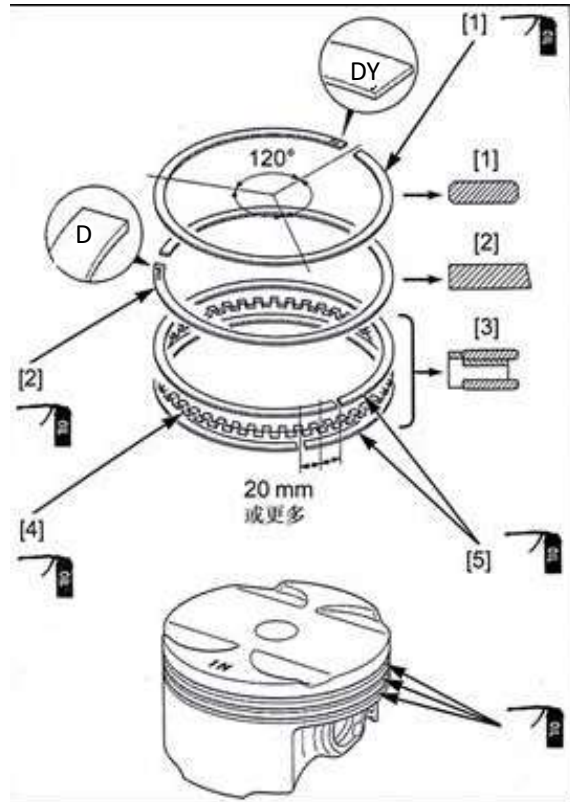

Re-assemble piston

Re-assemble shaft pad of crankshaft pin back to its initial position (Page 14-13) .

Coat internal surface of hole for piston pin with oil.

Coat internal surface of smaller end of connective rod with oil.

When matching up piston [1] and connective rod [2], get protrusion [3] for shaft pad of crankshaft pin facing to mark [4] of “●” on piston.

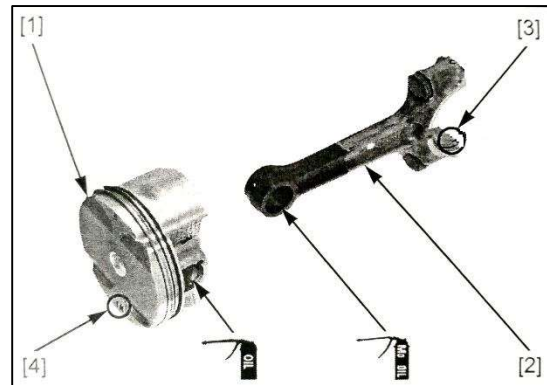

Coat external surface of piston pin with oil.

Re-assemble piston pin [1], then fix it by new circlip [2] of steel wire.

Caution:

- Make sure circlip of steel wire assembled in place.
- Please don't align opening on circlip to gap on piston.

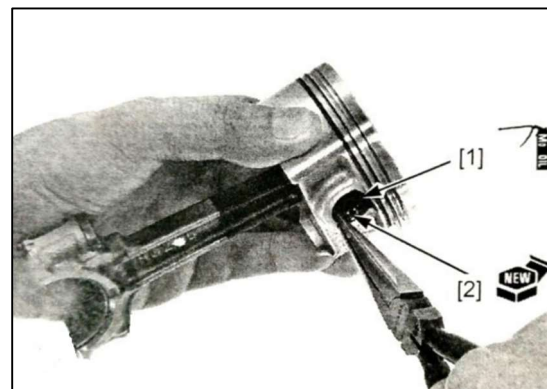

Coat cylinder wall and thrust surface of piston with oil.

Assemble piston/connective rod kit [1] into cylinder by compression tools could be bought from market (When assembling, the side on piston with mark “●” facing to air intaking direction).

When repeatedly using connective rod, they must be re-assembled to their original position.

Caution:

- *When re-assembling piston, please don't damage its top surface, especially don't damage matching place to cylinder hole.*
- *Please don't damage cylinder sleeve and crankshaft pin by connective rod.*

Slightly knock piston into cylinder body by plastic hammer (Make sure compressing tools for piston ring is flatly put on upper surface of cylinder body).

Re-assemble parts below:

- Crankshaft

- Balancing shaft

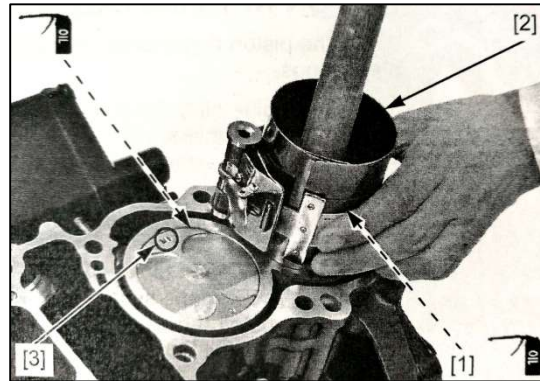

Oil nozzle for piston

Removal/Re-assembly

Remove piston/Connective rod.

Push the nozzle from cylinder body side to side of main shaft journal outwards (Please don't damage oil nozzle).

Remove o-ring from nozzle.

Totally clean up nozzle by solution liquid.

Check if nozzle blocked up, replace it in case it is necessary.

Clean up oil on nozzle and oil passage in upper crankcase by blowing of compressed air.

Assemble a new o-ring at groove of nozzle, coat it with oil before assembling.

Assemble nozzle into upper crankcase until it was completely in place. Assemble protrusion of nozzle and groove on crankcase.

Re-assemble the removed parts by opposite sequence to disassembly.

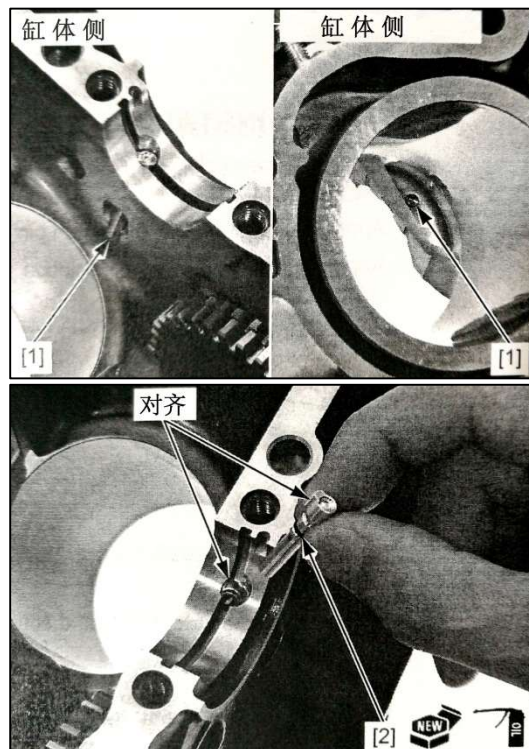

Balancing shaft

Removal

Remove piston/connective rod kit

Remove bolt [1] and pressing plate [2] for right side bearing of balancing/main shaft.

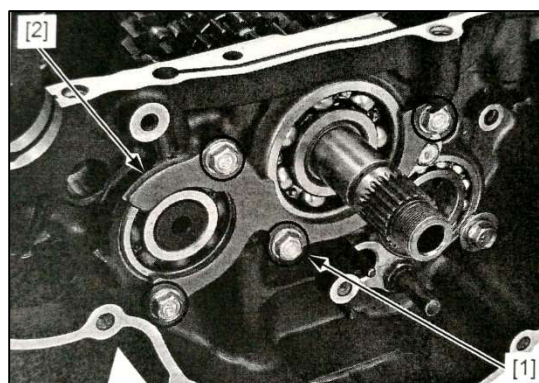

Turn balancing shaft [1], get it in a suitable angle, then slide balancing shaft to right in upper crankcase, then remove right side bearing [2] of balancing shaft.

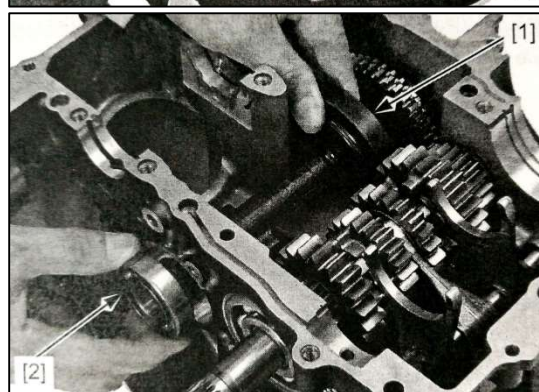

Remove balancing shaft [1].

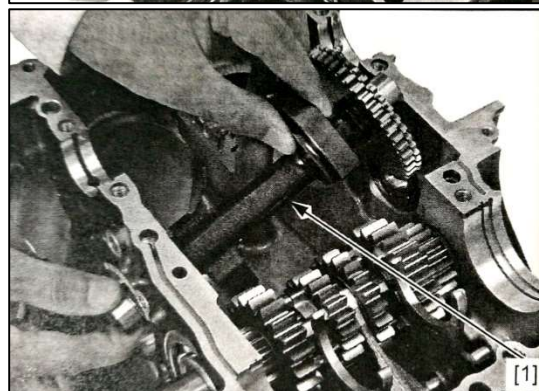

Inspection

Check if there is scratch, damage, wear-out or distortion on parts below, replace if it is necessary.

- Driven gear for balancing shaft
- Counter gear for driven gear on balancing shaft.
- Pressure spring for driven gear
- Balancing shaft
- Bearing for balancing shaft

Replace left side bearing of balancing shaft

Slightly knock left side bearing of balancing shaft out of upper crankcase.

Assemble a new left side bearing [1] for balancing shaft into upper crankcase by tools for this work only, slightly knock the bearing until it is in place (Slightly knock bearing in right angle, whose side with mark facing upwards).

Tool:

- [2] Driving rod
- [3] Damping piece
- [4] Guiding piece

Re-assembly

Coat left side bearing [1] of balancing shaft 给 with oil.

Assemble balancing shaft [2] into upper crankcase.

Coat right side bearing of balancing shaft with oil.

Assemble right side bearing [1] of balancing shaft into upper crankcase.

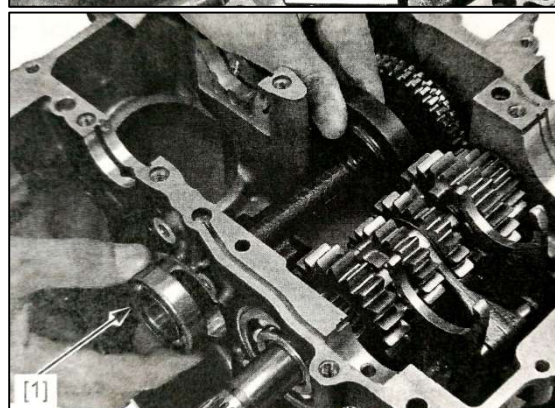
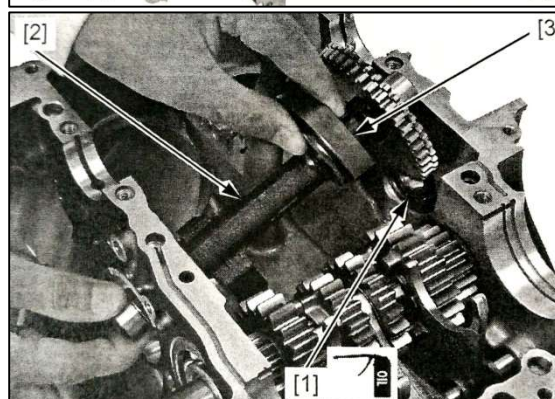
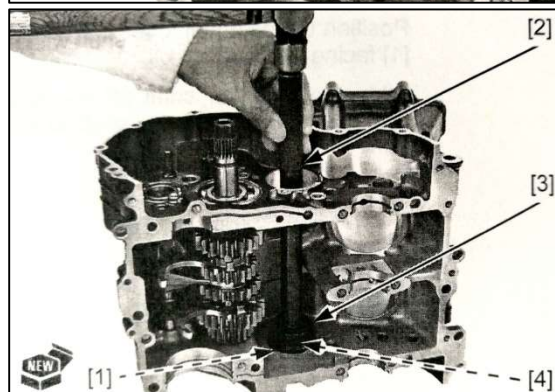
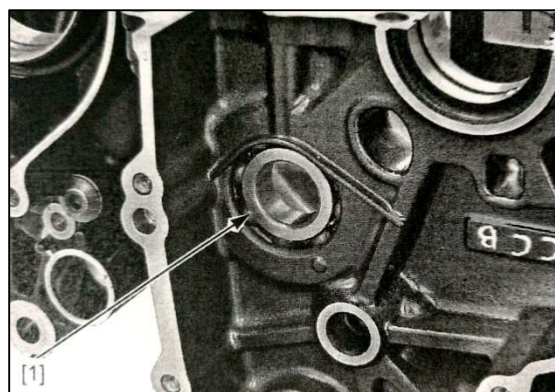

Coat threaded part of bolt for pressing plate of right side bearing for balancing/main shaft with Loctite.

Assemble pressing plate [1] for right side bearing for balancing/main shaft and bolt [2] for pressing plate.

Fasten bolt of pressing plate to given torque.

Torque: 11N.m

Assemble piston/connective rod kit.

